

## 200mA, 120-250V High Voltage SMD Switching Diode

### FEATURES

- Low power loss, high efficiency
- Ideal for automated placement
- High surge current capability
- Moisture sensitivity level: level 1, per J-STD-020
- Compliant to RoHS directive 2011/65/EU and in accordance to WEEE 2002/96/EC
- Halogen-free according to IEC 61249-2-21

### APPLICATIONS

- Switching mode power supply (SMPS)
- Adapters
- Lighting application
- On-board DC/DC converter

KEY PARAMETERS		
PARAMETER	VALUE	UNIT
$I_{F(AV)}$	200	mA
$V_{RRM}$	120-250	V
$I_{FSM}$	2.5	A
$V_F$ at $I_F=200mA$	1.25	V
$T_J$ MAX.	150	°C
Package	SOD-323F	
Configuration	Single die	



### MECHANICAL DATA

- Case: SOD-323F
- Molding compound meets UL 94 V-0 flammability rating
- Terminal: Matte tin plated leads, solderable per J-STD-002
- Meet JESD 201 class 1A whisker test
- Polarity: Indicated by cathode band
- Weight:  $4.5 \pm 0.5$  mg (approximately)



ABSOLUTE MAXIMUM RATINGS ( $T_A = 25^\circ\text{C}$ unless otherwise noted)					
PARAMETER	SYMBOL	BAV19WS	BAV20WS	BAV21WS	UNIT
Marking code on the device		S5	S6	S7	
Power dissipation	$P_D$	200			mW
Average forward current	$I_F$	200			mA
Repetitive peak reverse voltage	$V_{RRM}$	120	200	250	V
Peak forward surge current	Pulse Width = 1 s , Square Wave	0.5			A
	Pulse Width = 1 $\mu\text{s}$ , Square Wave				
Junction temperature range	$T_J$	-65 to +150			°C
Storage temperature range	$T_{STG}$	-65 to +150			°C

<b>ELECTRICAL SPECIFICATIONS</b> ( $T_A = 25^\circ\text{C}$ unless otherwise noted)						
<b>PARAMETER</b>		<b>CONDITIONS</b>	<b>SYMBOL</b>	<b>MIN</b>	<b>MAX</b>	<b>UNIT</b>
Forward voltage per diode <sup>(1)</sup>		$I_F = 100\text{mA}, T_J = 25^\circ\text{C}$	$V_F$	-	1.00	V
		$I_F = 200\text{mA}, T_J = 25^\circ\text{C}$		-	1.25	
Reverse voltage	BAV19WS	$I_R = 100\mu\text{A}, T_J = 25^\circ\text{C}$	$V_R$	120	-	V
	BAV20WS			200	-	
	BAV21WS			250	-	
Reverse current <sup>(2)</sup>	BAV19WS	$V_R = 100\text{V}, T_J = 25^\circ\text{C}$	$I_R$	-	100	nA
	BAV20WS	$V_R = 150\text{V}, T_J = 25^\circ\text{C}$				
	BAV21WS	$V_R = 200\text{V}, T_J = 25^\circ\text{C}$				
Junction capacitance		1 MHz, $V_R = 0\text{V}$	$C_J$	-	5	pF
Reverse recovery time		$I_F = I_R = 30\text{mA}, R_L = 100\Omega,$ $I_{RR} = 3\text{mA}$	$t_{rr}$	-	50	ns

**Notes:**

1. Pulse test with  $PW = 0.3\text{ ms}$
2. Pulse test with  $PW = 30\text{ ms}$

<b>ORDERING INFORMATION</b>		
<b>PART NO.</b>	<b>PACKAGE</b>	<b>PACKING</b>
BAV19WS RRG	SOD-323F	3K / 7" Reel
BAV19WS RR	SOD-323F	3K / 7" Reel
BAV19WS R9G	SOD-323F	10K / 13" Reel
BAV19WS R9	SOD-323F	10K / 13" Reel
BAV20WS RRG	SOD-323F	3K / 7" Reel
BAV20WS RR	SOD-323F	3K / 7" Reel
BAV20WS R9G	SOD-323F	10K / 13" Reel
BAV20WS R9	SOD-323F	10K / 13" Reel
BAV21WS RRG	SOD-323F	3K / 7" Reel
BAV21WS RR	SOD-323F	3K / 7" Reel
BAV21WS R9G	SOD-323F	10K / 13" Reel
BAV21WS R9	SOD-323F	10K / 13" Reel

**CHARACTERISTICS CURVES**

( $T_A = 25^\circ\text{C}$  unless otherwise noted)

**Fig.1 Typical Forward Characteristics**

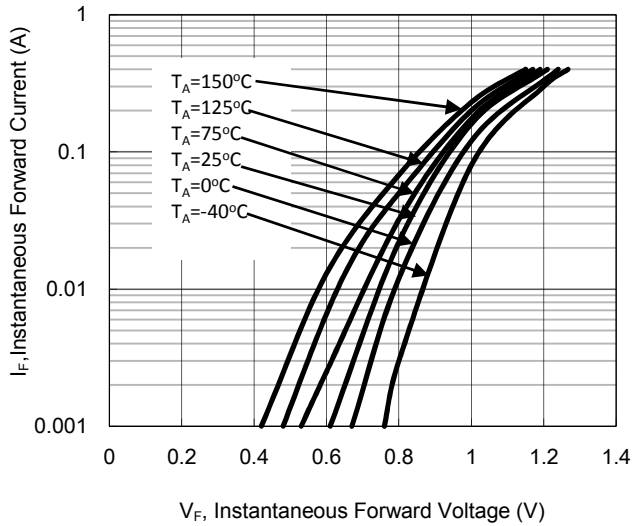

**Fig.2 Typical Reverse Characteristics**

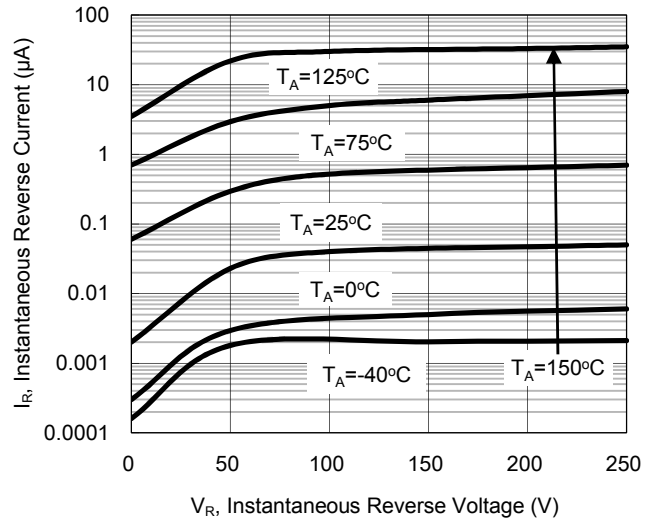

**Fig.3 Typical Capacitance VS. Reverse Voltage**

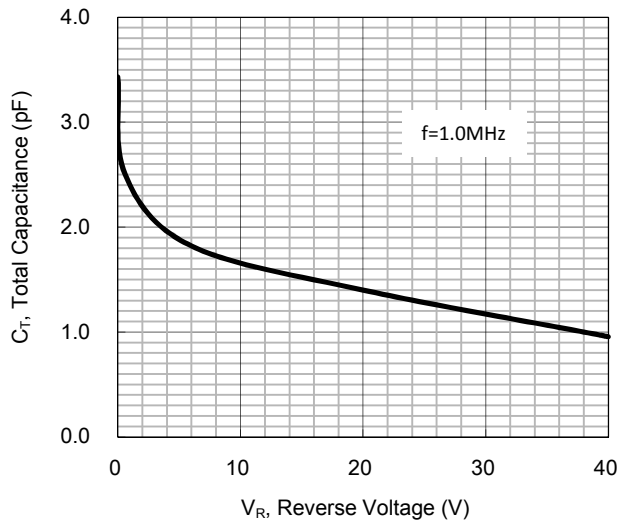

**Fig.3 Power Derating Curve**

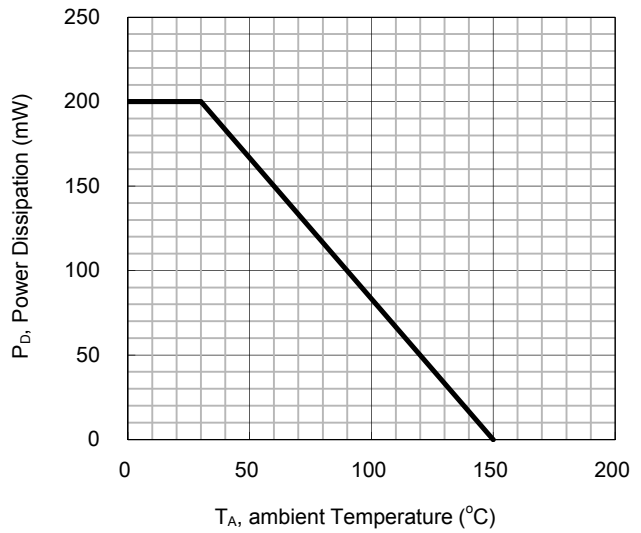

**PACKAGE OUTLINE DIMENSION**

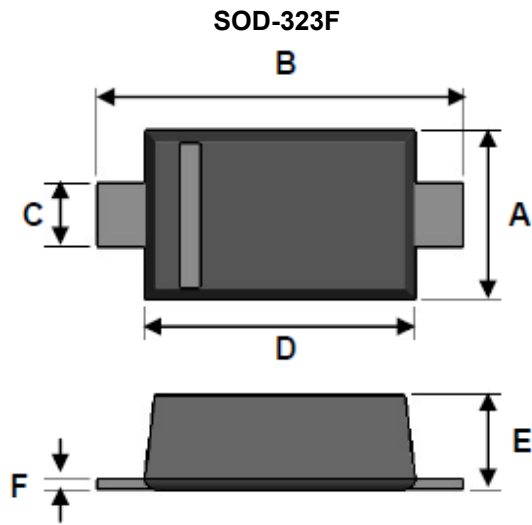

DIM.	Unit (mm)		Unit (inch)	
	Min	Max	Min	Max
A	1.15	1.35	0.045	0.053
B	2.30	2.80	0.091	0.110
C	0.25	0.40	0.010	0.016
D	1.60	1.80	0.063	0.071
E	0.80	1.10	0.031	0.043
F	0.05	0.25	0.002	0.010

**SUGGEST PAD LAYOUT**

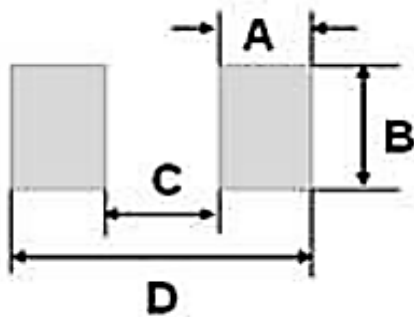

DIM.	Unit (mm)	Unit (inch)
	Typ.	Typ.
A	0.63	0.025
B	0.83	0.033
C	1.60	0.063
D	2.86	0.113

## Notice

Specifications of the products displayed herein are subject to change without notice. TSC or anyone on its behalf, assumes no responsibility or liability for any errors or inaccuracies.

Information contained herein is intended to provide a product description only. No license, express or implied, to any intellectual property rights is granted by this document. Except as provided in TSC's terms and conditions of sale for such products, TSC assumes no liability whatsoever, and disclaims any express or implied warranty, relating to sale and/or use of TSC products including liability or warranties relating to fitness for a particular purpose, merchantability, or infringement of any patent, copyright, or other intellectual property right.

The products shown herein are not designed for use in medical, life-saving, or life-sustaining applications. Customers using or selling these products for use in such applications do so at their own risk and agree to fully indemnify TSC for any damages resulting from such improper use or sale.

# Mouser Electronics

Authorized Distributor

Click to View Pricing, Inventory, Delivery & Lifecycle Information:

[Taiwan Semiconductor:](#)

[BAV19WS](#) [BAV21WS RR](#) [BAV21WS RRG](#) [BAV19WS RRG](#) [BAV19WS RR](#) [BAV20WS RRG](#) [BAV20WS RR](#)