

Figure 1

## 1. INTRODUCTION

Pneumatic Crimping Heads 1213850-1 and -2 are designed to crimp STRATO-THERM non-insulated terminals and splices with insulation support on wire sizes 22 to 14 AWG. The crimping heads are used with 626 Pneumatic Tool Holder Assemblies. Figure 1 shows the tool holder assemblies, and lists the pneumatic tooling assemblies for the crimping heads.

This instruction sheet provides recommended procedures for insulation crimp adjustments, wire preparation, crimp head installation, crimping, and maintenance and inspection. For information concerning tool setup and operation, refer to customer manual 409-5862. Product specifications and part numbers are available in Tyco Electronics Catalogs. See Figure 1.

Read these instructions thoroughly before proceeding.

**NOTE**  Measurements are in metric units [followed by U.S. customary units in brackets]. Figures are for reference only and are not drawn to scale.

## 2. DESCRIPTION (Figure 1)

The pneumatic crimping heads consist of integral jaws which close in an arc-like motion. After an operator

locates the terminal or splice between the crimping jaws and inserts the stripped wire, the tool is activated to crimp the product to the wire.

## 3. HEAD INSTALLATION AND REMOVAL

### 3.1. Installation

**NOTE**  Crimping heads are coated with a preservative to prevent rust and corrosion. Wipe any excess preservative from the head, particularly from crimping surfaces.

**CAUTION**  Certain precautions should be taken by the operator to avoid personal injury or damage to the pneumatic tool. Refer to the instructions packaged with the pneumatic tool for operation procedures and safety precautions.

**DANGER**  To avoid personal injury, ALWAYS disconnect tool from air supply before installing crimping head.

**DANGER**  Do NOT operate pneumatic tool without proper crimping head installed; make sure that the quick pins are FULLY tightened to avoid personal injury and damage to the tool.

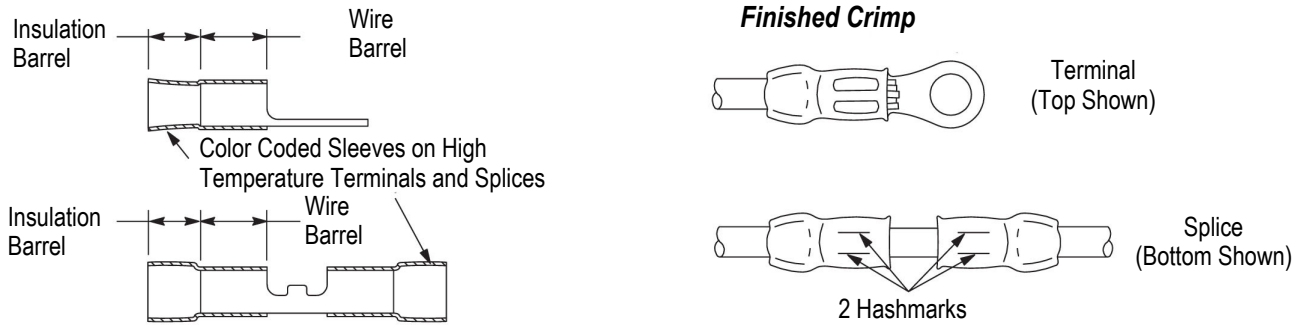

PNEUMATIC TOOLING ASSEMBLIES	CRIMPING HEADS	WIRE RANGE SIZE	HASHMARK CODE†	WIRE STRIP LENGTH	
				MIN.	MAX.
189721-1	1213850-1	22 - 16	1 Hashmark	5.16	5.94
189722-1	1213850-2	16 - 14	2 Hashmarks	[.203]	[.234]

† A Hashmark code Should Appear on the Bottom (Side Opposite Crimp Indents) for High Temperature and Heat Resistant Terminals and Splices when Crimped with the Proper Crimp Head.

Figure 2

Determine the wire size, then refer to Figure 2 to select the appropriate crimping head. Proceed as follows:

1. Remove quick pins from tool holder. Refer to Figure 1.
2. Insert crimping head into the tool holder of the power unit, as shown in Figure 1.
3. After crimping head is properly aligned, insert and tighten the quick pins provided with the pneumatic tooling assembly.

**NOTE** *It is recommended using LOCTITE‡ 242 removable thread lock, or equivalent, to prevent the quick pins from loosening.*

4. Connect tool to an adequate air supply between 620 to 690 kPa [90 to 100 psi]. For specific information on air line requirements and air hose installation, refer to the instructions packaged with the tooling assembly.

### 3.2. Removal

**DANGER** *ALWAYS disconnect tool from air supply before removing crimping head.*

1. Remove quick pins from crimping head. See Figure 1.
2. Remove crimping head from tool holder.

## 4. CRIMPING PROCEDURES

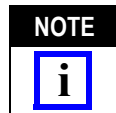

*Refer to Paragraph 4.3 for insulation crimp adjustments.*



*To avoid personal injury, exercise caution while holding terminals or splices near the crimping jaws.*

### 4.1. Terminal Crimping Procedure

1. Strip wire to the dimensions shown in Figure 2. DO NOT nick the wire or use wires with nicked or missing conductor strands.
2. Open the crimping jaws by squeezing the rollers together simultaneously.
3. Then position a terminal between the crimping jaws as shown in Figure 3. The edge of the terminal wire barrel must rest against the locator.
4. After the terminal is properly positioned in the crimping jaws, release the rollers to allow the crimping jaws to spring shut, holding the terminal in place.
5. Insert a stripped wire into the terminal; then activate the tool to complete the crimp. Open the crimping jaws by squeezing the rollers together simultaneously.
6. Then remove the crimped terminal.
7. Refer to Section 5 and Figure 6 for crimp inspections

‡ Trademark of Loctite Corporation

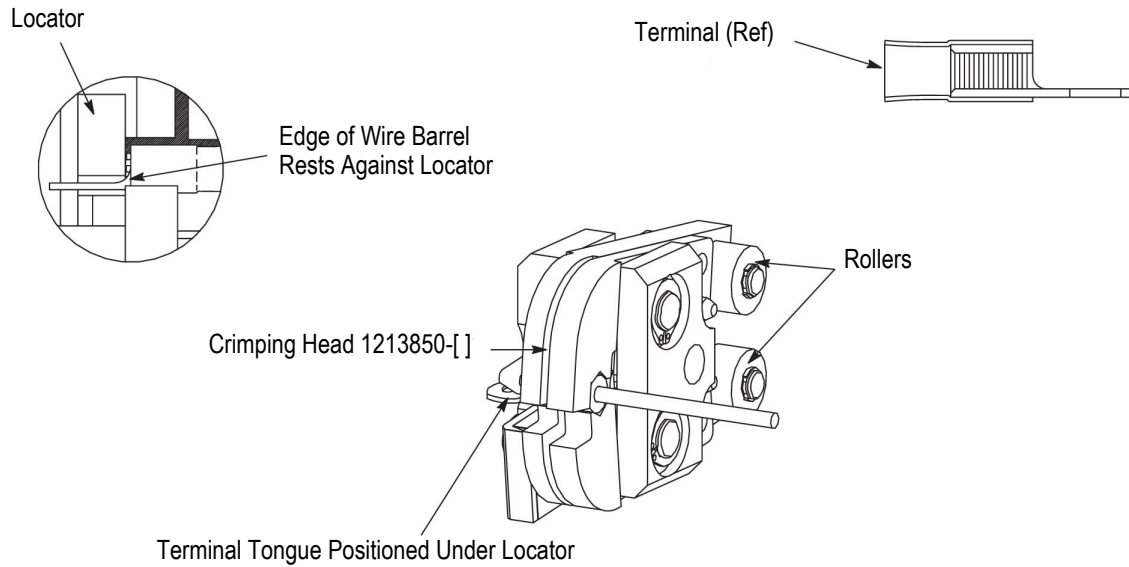
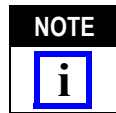

Figure 3

#### 4.2. Splice Crimping Procedure

1. Strip wire to the dimensions shown in Figure 2. Do NOT nick the wire or use wires with nicked or missing conductor strands.
2. Open the crimping jaws by squeezing the rollers together simultaneously. Position the splice between the crimping jaws so that the window indent of the splice slides under the locator of the crimping head. See Figure 4, Detail A. For best results, when brazed seam on the splice is visible, position the seam toward the “W” shaped jaw.

3. Insert the stripped wire into the wire barrel until the end of the conductor is positioned against the splice wire stop. See Figure 4, Detail A.
4. Activate the tool to complete crimp. Remove the splice from the crimping jaws.
5. To crimp the other half of the splice, reposition uncrimped half in the crimping jaws. Repeat Steps 1 through 4 to complete the crimp. See Figure 4, Detail B.



Rotate the crimping head if the splice cannot be repositioned in the crimping jaws.

6. Refer to Section 5 and Figure 6 for crimping inspection.

**First Crimp**

**Detail A**

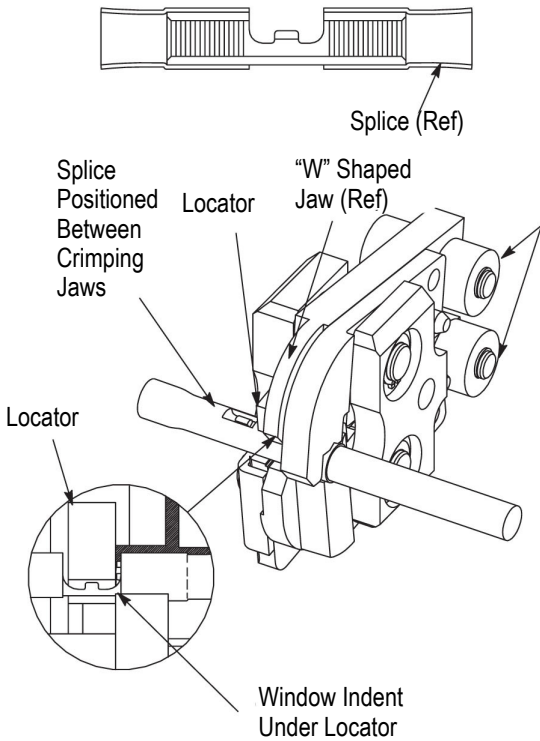

**Second Crimp**

**Detail B**

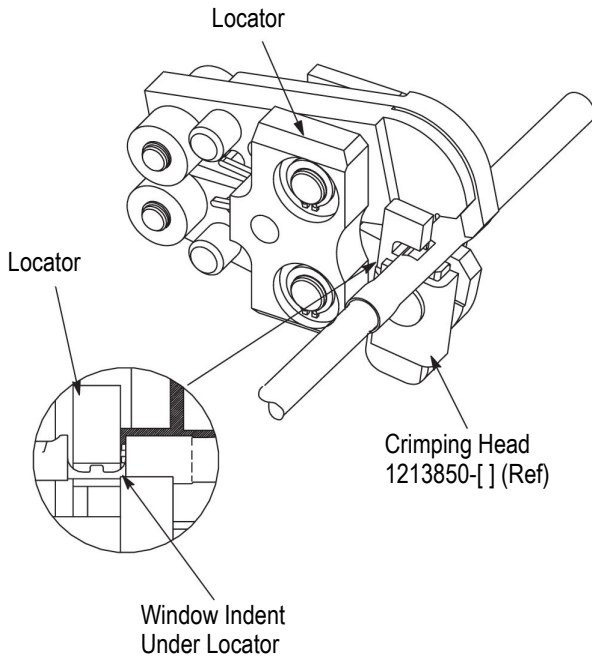

Figure 4

**4.3. Insulation Crimp Adjustment**

The insulation crimping section of the crimping head has three positions: 1-tight; 2-medium; and 3-loose. Adjust the insulation crimp as follows:

1. Insert the insulation adjustment pins in position 3. See Figure 5.
2. Place the terminal or splice in the crimping jaws.
3. Insert **unstripped** wire into the **insulation grip portion** of the terminal or splice.
4. Crimp the terminal or splice as described in Paragraph 4.1 or 4.2.
5. Remove the terminal or splice. Bend the wire forward and then backward. The terminal or splice should retain its grip on the wire. If the wire pulls out, set the insulation adjustment pins in the next tighter position and repeat the crimping procedure.
6. Repeat the adjustment as necessary until the desired insulation grip is obtained. **DO NOT** use a tighter setting than required.

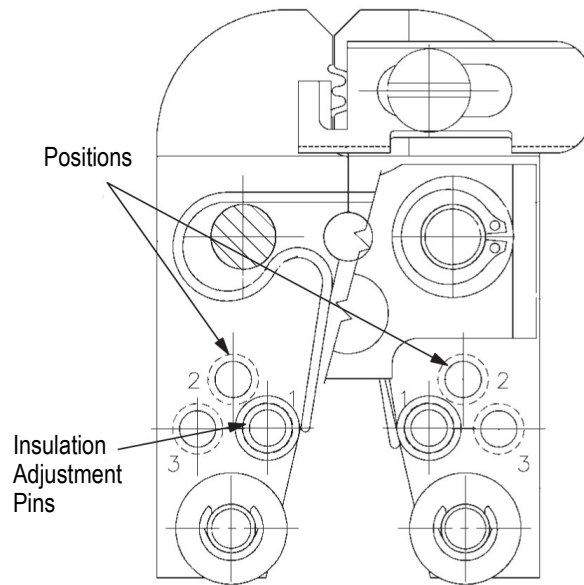
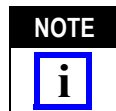

Figure 5



**NOTE** Always place both adjustment pins in the same position. See Figure 5.

**5. CRIMP INSPECTION**

Inspect crimped terminals and splices by checking the features described in Figure 6. Use only the terminals and splices that meet the conditions in the "ACCEPT" column.

"REJECT" terminations can be avoided through careful use of the instructions provided in Section 4, and by performing regular crimping head maintenance as described in Section 6.

**Crimp Inspection**

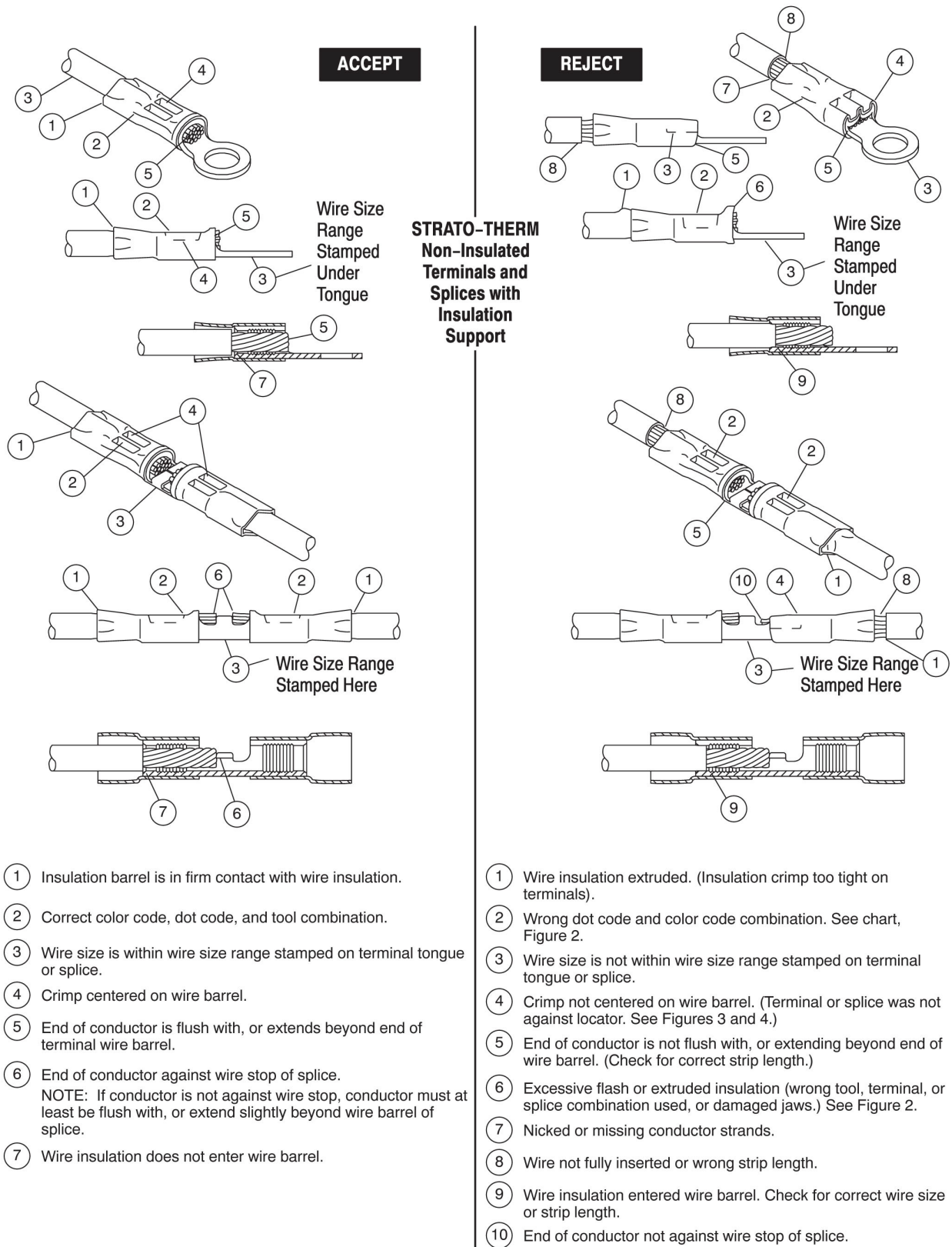

Figure 6





A hashmark code (see Figure 2) should appear on the bottom (side opposite the crimp indents) for high temperature and heat-resistant terminals and splices when crimped with the proper crimping head.

## 6. MAINTENANCE AND INSPECTION



To avoid personal injury, disconnect air supply from pneumatic tool before performing maintenance, inspection, or repair procedures.

It is recommended that a maintenance and inspection program be performed periodically to ensure dependable and uniform terminations.

### 6.1. Daily Maintenance

It is recommended that each operator be responsible for the following four steps of daily maintenance:

1. Remove dust, moisture, and other contaminants with a clean, soft brush or a lint-free cloth. Do NOT use objects that could damage the heads.
2. Make sure that all pins, rings and other components are in place and secure.
3. Make certain all surfaces are protected with a thin coat of any good SAE 20 motor oil. Do NOT oil excessively. Wipe excess grease from head, particularly die closure areas.
4. When head assembly is not in use, store it in a clean dry area.

### 6.2. Periodic Inspection

Regular inspections should be performed by quality-control personnel. A record of scheduled inspections should remain with the crimping heads or be supplied to supervisory personnel responsible for the crimping heads. Though recommendations call for at least one inspection a month, the frequency should be based on amount of use, working conditions, operator training and skill, and your established company policies. These inspections should include a visual inspection (Paragraph 6.3) and a crimping chamber inspection (Paragraph 6.5).

### 6.3. Visual Inspection

1. Make certain all components are in place. Inspect for missing pins and retaining rings. If replacements are necessary, refer to Figure 10.
2. Check all bearing surfaces for wear. Replace worn parts.
3. Inspect the crimp area for flattened, chipped, or broken areas. See Figure 7. Replace worn or damaged parts.

### 6.4. Lubrication

Lubricate all pins, pivot points, and bearing surfaces with a high quality grease. Tyco recommends the use

of Molykote♦ paste, which is a commercially available lubricant. Lubricate according to the following schedule:

- Head used in daily production - lubricate daily
- Head used daily (occasional) - lubricate weekly
- Head used weekly - lubricate monthly



Wipe excess grease from crimping head, particularly jaw closure areas. Grease transferred from the jaw closure area onto certain terminations may affect the electrical characteristics of an application.

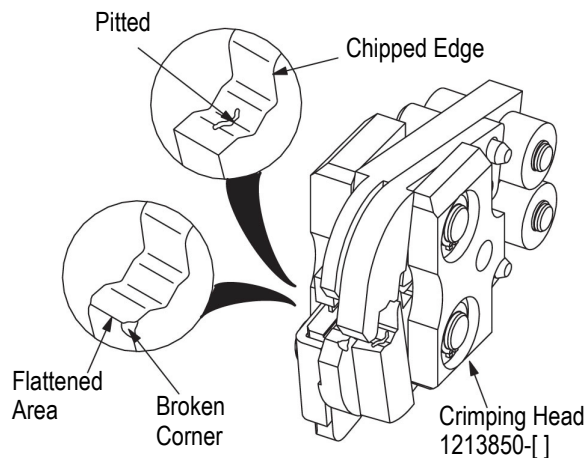

Figure 7

### 6.5. Gaging the Crimping Chamber

This inspection requires the use of plug gages conforming to the dimensions shown in Figure 8. Tyco Electronics does not manufacture or sell these gages. Refer to 408-7424. Proceed as follows:



To avoid personal injury, disconnect air supply from pneumatic tool and remove head from tool.

1. Remove oil and dirt from jaw bottoming surfaces, jaw closure surfaces, and plug gage elements.
2. Set insulation adjustment pins in position 3. This will allow access to the wire barrel crimping jaws from the insulation crimp side of the head.
3. Close wire barrel crimping jaws until they are bottomed, but not under pressure.
4. Align GO element with crimping chamber. Push element straight into crimping chamber without using force. The GO element must pass completely through the chamber. See Figure 9, Detail A.

♦ Trademark of Dow Corning Corporation

5. Align NO-GO element and try to insert it into the crimp chamber. The element may start entry, but it must not pass completely through the crimping chamber.

6. Set insulation adjustment pins to position 1 and repeat this procedure for insulation crimp chamber. Refer to Figure 9, Detail B.

If crimping chambers pass plug gage inspection, the crimping head is considered dimensionally correct. If crimping chambers do not pass this inspection, contact your local Tyco Electronics Field Representative or refer to Section 7, REPLACEMENT AND REPAIR.

For additional information about the use of a plug gage, see instruction sheet 408-7424.

**7. REPLACEMENT AND REPAIR**

Customer-replaceable parts are listed in Figure 10. A complete inventory should be stocked and controlled to prevent lost time when replacement of parts is necessary. Parts other than those listed should be replaced by Tyco to ensure quality and reliability. Order replacement parts through your representative, or call 1-800-526-5142, or send a facsimile of your purchase order to 717-986-7605, or write to:

CUSTOMER SERVICE (038-035)  
 TYCO ELECTRONICS CORPORATION  
 PO BOX 3608  
 HARRISBURG PA 17105-3608

For customer repair service, please contact a representative at 1-800-526-5136.

**8. REVISION SUMMARY**

Since the previous release of this document, the TE logo has been applied.

**Suggested Plug Gage Design**

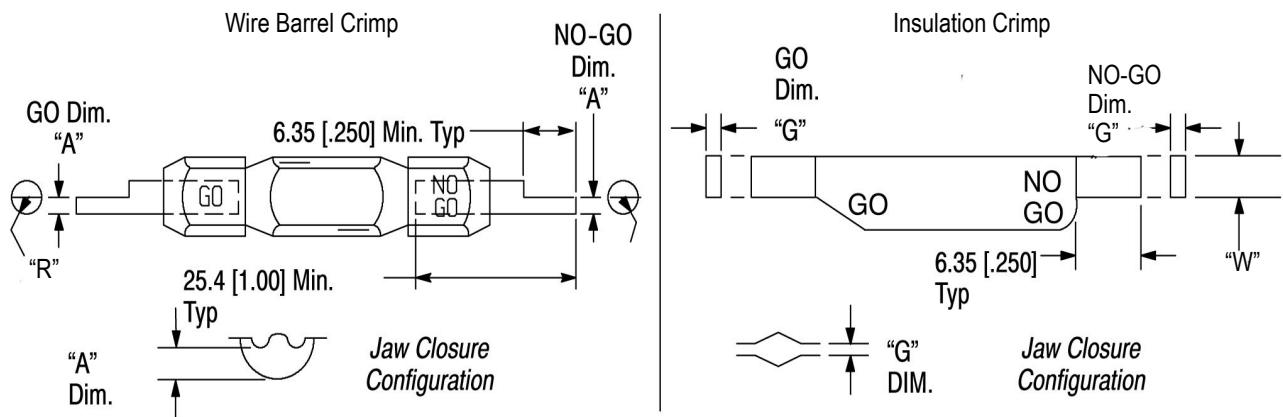

CRIMPING HEADS	WIRE BARREL DIMENSIONS "A" mm [In.]		RADIUS "R"	INSULATION BARREL DIMENSIONS "G" (Adjustment Pins in Position 1) mm [In.]		WIDTH "W" (Max.)
	GO	NO-GO		GO	NO-GO	
1213850-1	1.50 [.059]	1.65 [.065]	1.57 [.062]	0.76 [.030]	1.27 [.050]	3.18 [.125]
1213850-2	1.70 [.067]	1.85 [.073]	1.57 [.062]	1.02 [.040]	1.52 [.060]	4.78 [.188]

Figure 8

**Inspection of Wire Barrel Crimping Jaws with Plug Gage**

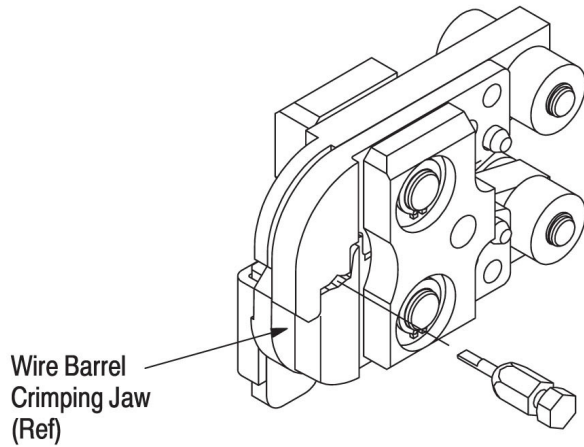

**Detail A**

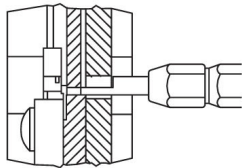
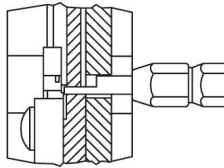

**Inspection of Insulation Crimping Jaws with Plug Gage**

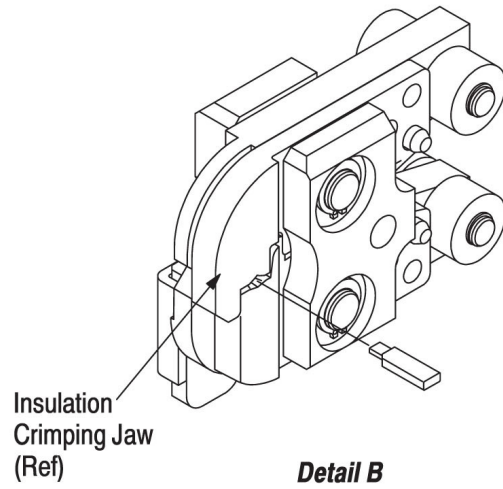

**Detail B**

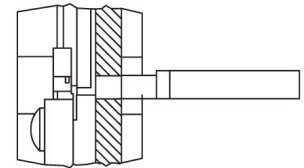
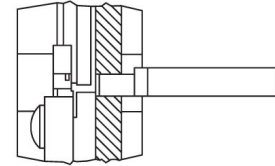

“GO” element must pass completely through the crimping jaws.

“NO-GO” element may enter partially, but must not pass completely through the crimping jaws.



*Crimping head guard NOT shown for clarity.*

Figure 9



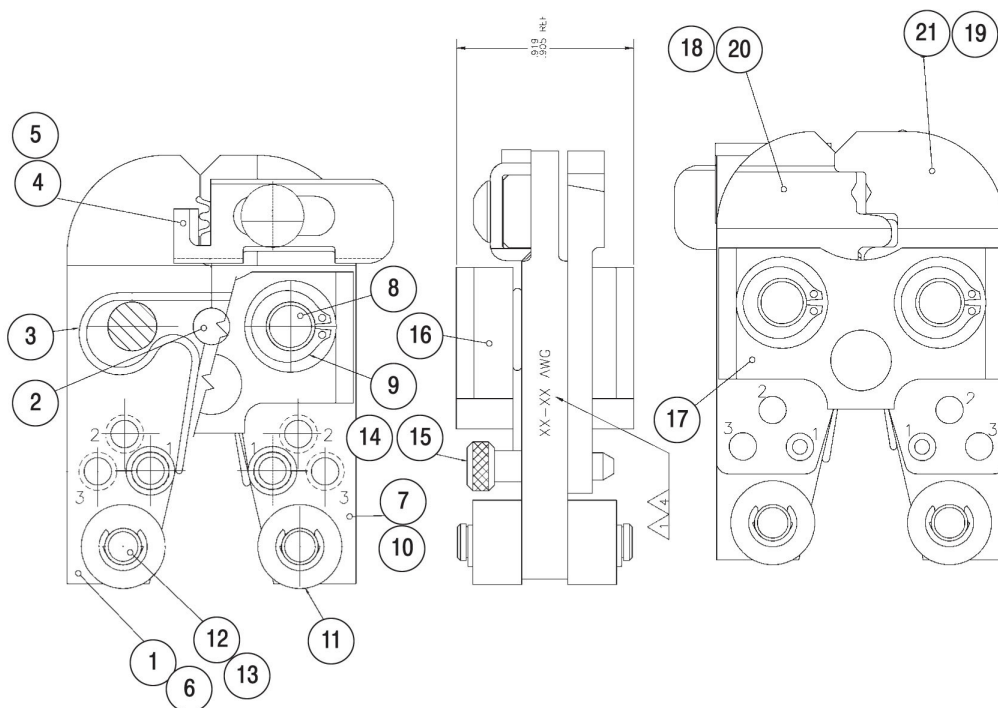

ITEM NUMBER	DESCRIPTION	USED ON CRIMPING HEAD		QTY PER ASSEMBLY
		1213850-1	1213850-2	
1	INDENTER	1213847-1	--	1
2	PIN	39085	39085	1
3●	SPRING	314253-1	314253-1	1
4	LOCATOR ASSEMBLY	305359-2	--	1
5	LOCATOR ASSEMBLY	--	305359	1
6	INDENTER	--	1213847-2	1
7	NEST	--	1213848-2	1
8	PIN, Str Grv .2500 In Dia	3-23628-4	3-23628-4	2
9	RING, Retaining	21048-7	21048-7	4
10	NEST	1213848-1	--	1
11●	ROLLER	314479-1	314479-1	4
12●	PIN, Str Grv .1875 In Dia	3-23619-7	3-23619-7	2
13	RING, Retaining	21045-3	21045-3	4
14	RING	39208-1	39208-1	6
15	PIN, Adjustment	39207-1	39207-1	2
16	LINK	314477-1	314477-1	1
17	LINK	314477-2	314477-2	1
18	ANVIL, Insulation	314563-5	--	1
19	INDENTER, Insulation	314562-7	--	1
20	ANVIL, Insulation	--	314563-1	1
21	INDENTER, Insulation	--	314562-1	1

● Recommended Spare Parts

Figure 10

# Mouser Electronics

Authorized Distributor

Click to View Pricing, Inventory, Delivery & Lifecycle Information:

[TE Connectivity:](#)

[1213850-1](#)