

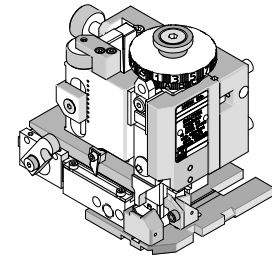

**Mini-Mac
Applicator**

**Application Tooling
Specification Sheet**



Order No. 63892-9000

FEATURES

- Directly adapts to most automatic wire processing machines
- Applicator designed to industry standard mounting and shut height 135.80mm (5.346")
- Quick set-up time; plus the crimp height, track and feed adjustments can be set without removing the applicator from the press
- Fine adjustment allows users to achieve target with little effort by adjusting in increments of .015mm (.0006") for conductor crimp height and .063mm (.0025") for insulation height
- Independent adjustment rings allow users to quickly adjust the conductor or insulation crimp height without affecting each other.

SCOPE

Products: Disk Drive Power Connection System, Female Crimp Terminal, 14-20 AWG.

Terminal Series No.	Terminal Order No.	Wire Size		Insulation Diameter Max.		Strip Length	
		AWG	mm ²	mm	In.	mm	In.
8980-3	02-08-1201	14-20	2.00-0.50	3.06	.120	4.75-5.54	.187-.218

DEFINITION OF TERMS

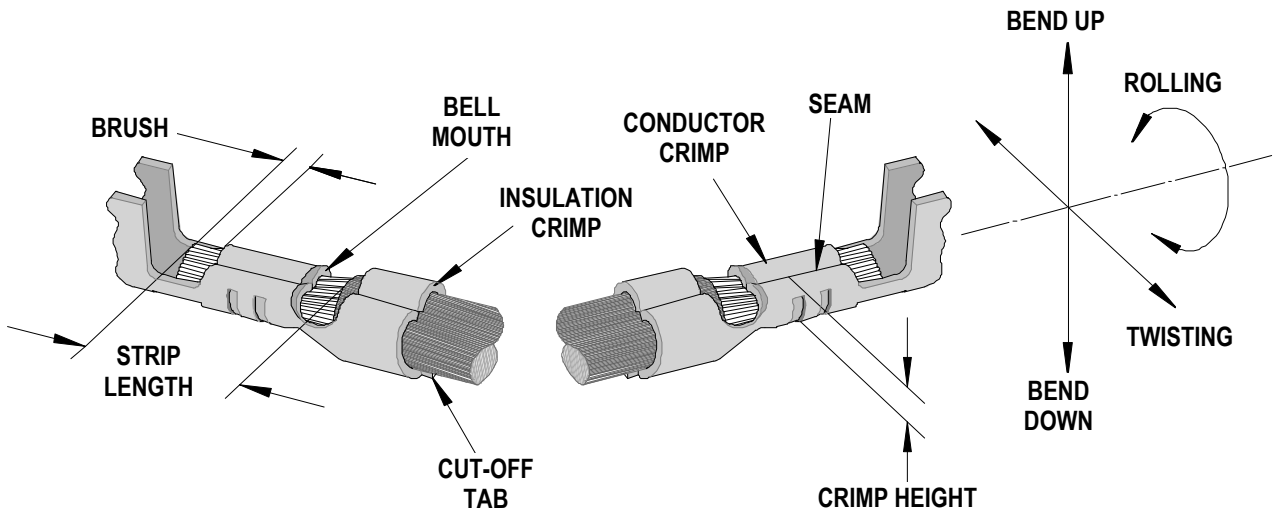

The above terminal drawing is a generic terminal representation. It is not an image of a terminal listed in the scope.

CRIMP SPECIFICATIONS

Terminal Series No.	Wire Size		Bell mouth (Ref.)		Cut-off Tab		Conductor Brush	
	AWG	mm ²	mm	In.	mm	In.	mm	In.
8980-3	14-20	2.00-0.50	0.20-0.50	.008-.020	0.00-0.30	.000-.012	1.20-2.10	.047-.083

Terminal Series No.	Bend up Bend down		Twist	Roll	Punch Width (Ref)				Seam Seam shall not be open and no wire allowed out of the crimping area
	Degree				Degree		Conductor		
	mm	In.	mm	In.	mm	In.	mm	In.	
8980-3	6	3	4	8	2.30	.090	3.125	.123	

After crimping, the conductor profile should measure the following.

Terminal Series No.	Wire Size		Conductor		Insulation		Pull Force Minimum	
	Crimp Height		Crimp Height		Crimp Height		N	Lb.
	AWG	mm ²	mm	In.	mm	In.		
8980-3	14	2.00	1.47-1.52	.058-.060			177.9	40.0
	16	1.30	1.37-1.42	.054-.056			155.7	35.0
	18	0.80	1.29-1.35	.051-.053			133.4	30.0
	20	0.50	1.22-1.27	.048-.050			80.1	18.0

Pull Force should be measured with no influence from the insulation crimp.
The above specifications are guidelines to an optimum crimp.

NOTE: Some of the specifications in these charts above are intentionally left blank due to the fact that the information does not currently exist.

PARTS LIST

Mini-Mac Applicator 63892-9000				
Item	Order No	Engineering No.	Description	Quantity
Perishable Tooling				
	63892-9070	63892-9070	Tool Kit (All "Y" Items)	REF
1	11-18-4628	60750A101	Conductor Punch	1 Y
2	11-18-4629	60750A102	Combination Anvil	1 Y
3	11-18-4630	60750A103	Insulation Punch	1 Y
4	11-17-3076	7163-30	Front Cut-Off Plunger	1 Y
5	11-17-3079	7163-33	Rear Cut-Off Plunger	1 Y
6	11-18-4066	60710-6	Cut-Off Blade	1 Y
7	11-18-4246	60707-18	Front Plunger Guide Block	1 Y
8	11-18-4247	60707-19	Rear Plunger Guide Block	1 Y
Other Components				
9	11-18-4081	60707-6	Front Plunger Striker	1
10	11-18-4082	60707-7	Back Plunger Striker	1
11	11-18-4083	60707-8	Feed Guide	1
12	11-18-4631	60750A104	Spacer	1
13	11-18-4632	60750A105	Rear Cover	1
14	11-18-5060	60707-21	Cut-Off Plunger Spring	2
15	63443-0090	63443-0090	Wire Stop	1
16	63803-5114	63803-5114	Conductor Bushing	1
Frame				
17	63801-3201	63801-3201	Top	1
18	63801-3282	63801-3282	Base	1
19	63801-6550	63801-6550	Track	1
Hardware				
20	N/A	N/A	M3 by 8 Long SHCS	2**
21	N/A	N/A	M4 by 6 Long SHCS	1**
22	N/A	N/A	M4 by 10 Long SHCS	2**
23	N/A	N/A	M4 by 20 Long SHCS	2**
24	N/A	N/A	M5 by 10 Long SHCS	1**
25	N/A	N/A	M8 by 20 Long BHCS	1**
26	N/A	N/A	#6-32 by 3/8" Long BHCS	4**
27	N/A	N/A	#8-32 by 1/4" Long SHCS	2**
28	N/A	N/A	#8-32 by 1/2" Long BHCS	1**
** Available from an industrial supply company such as MSC (1-800-645-7270).				

Assembly Drawing

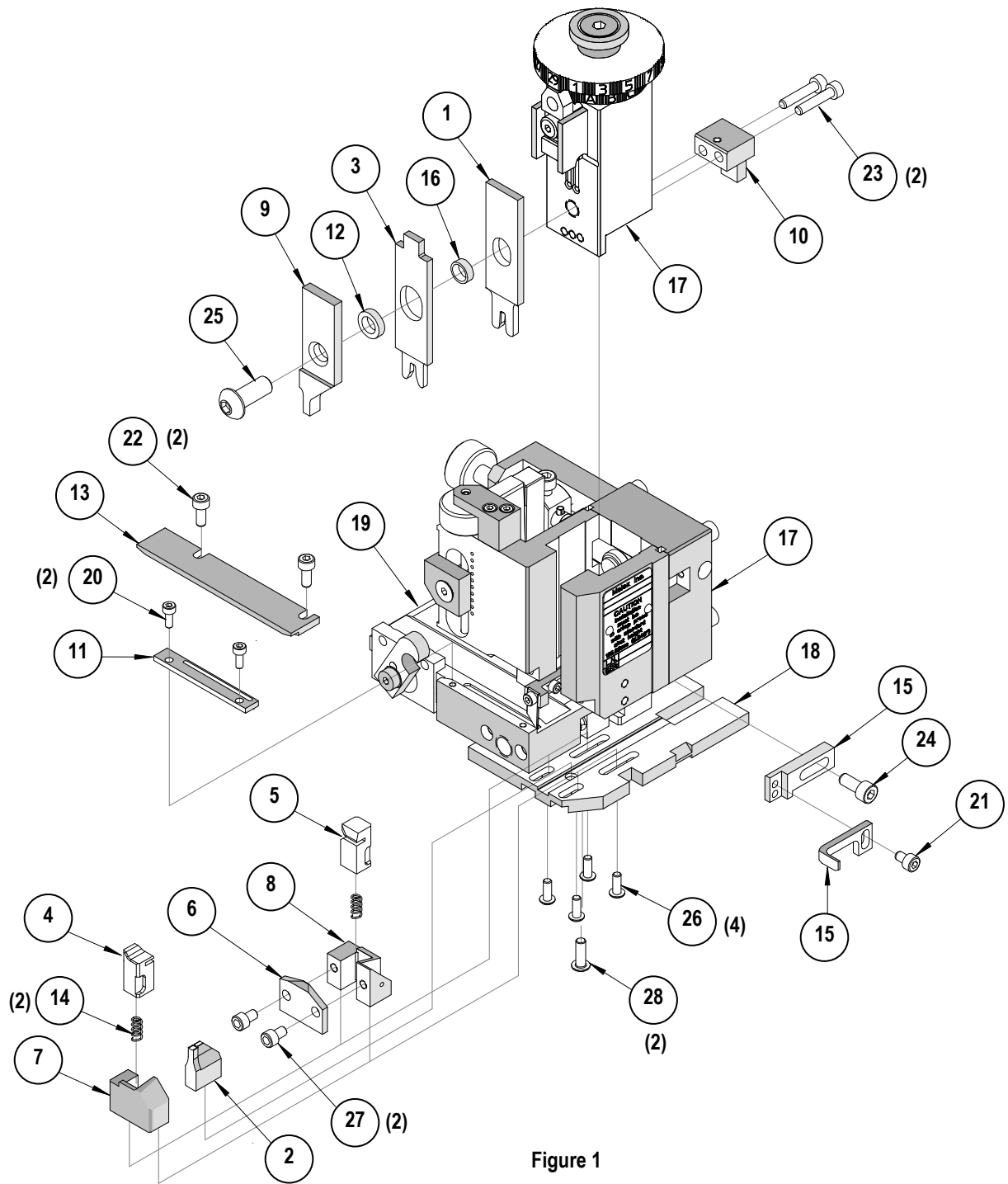

NOTES

1. Molex recommends an extra perishable tooling kit be maintained at your facility.
2. Verify tooling alignment by manually cycling the press and applicator before crimping under power. Check that all screws are tight.
3. Slugs, terminals, dirt, and oil should be kept clear of work area.
4. Wear safety glasses at all times.
5. For recommended maintenance refer to the Mini-Mac Manual.

CAUTION: This applicator should only be used in a press with a shut height of 135.80mm (5.346"). Tooling damage could result at a lower setting.

CAUTION: To prevent injury, never operate this applicator without the guards supplied with the press or wire-processing machine in place. Reference the press or wire processing manufacturer's instruction manual.

CAUTION: Molex crimp specifications are valid only when used with Molex terminals, applicators and tooling.

Contact Information

For more information on Molex application tooling please contact Molex at 1-800-786-6539.

<http://www.molex.com>

Mouser Electronics

Authorized Distributor

Click to View Pricing, Inventory, Delivery & Lifecycle Information:

[Molex:](#)

[63892-9070](#)