

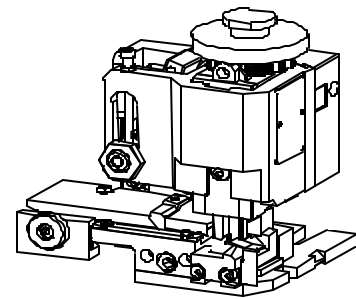

SPECIFICATION SHEET
FineAdjust Applicator
63865-4100
REVISION A



SCOPE

Terminal Series No		Wire Size		Insulation Diameter		Strip Length	
		Awg	(mm ²)	mm	(in)	mm	(in)
33012-1003	Female (tin)	22	(0.36)	1.50-1.65	(.059-.065)	4.70-5.60	(.185-.220)
33001-1005	Female (gold)	22	(0.36)	1.50-1.65	(.059-.065)	4.70-5.60	(.185-.220)

Wire Specs: Wires to be thin wall thickness per Ford's specification MIL135-A1 and MIL123-A

DEFINITION OF TERMS

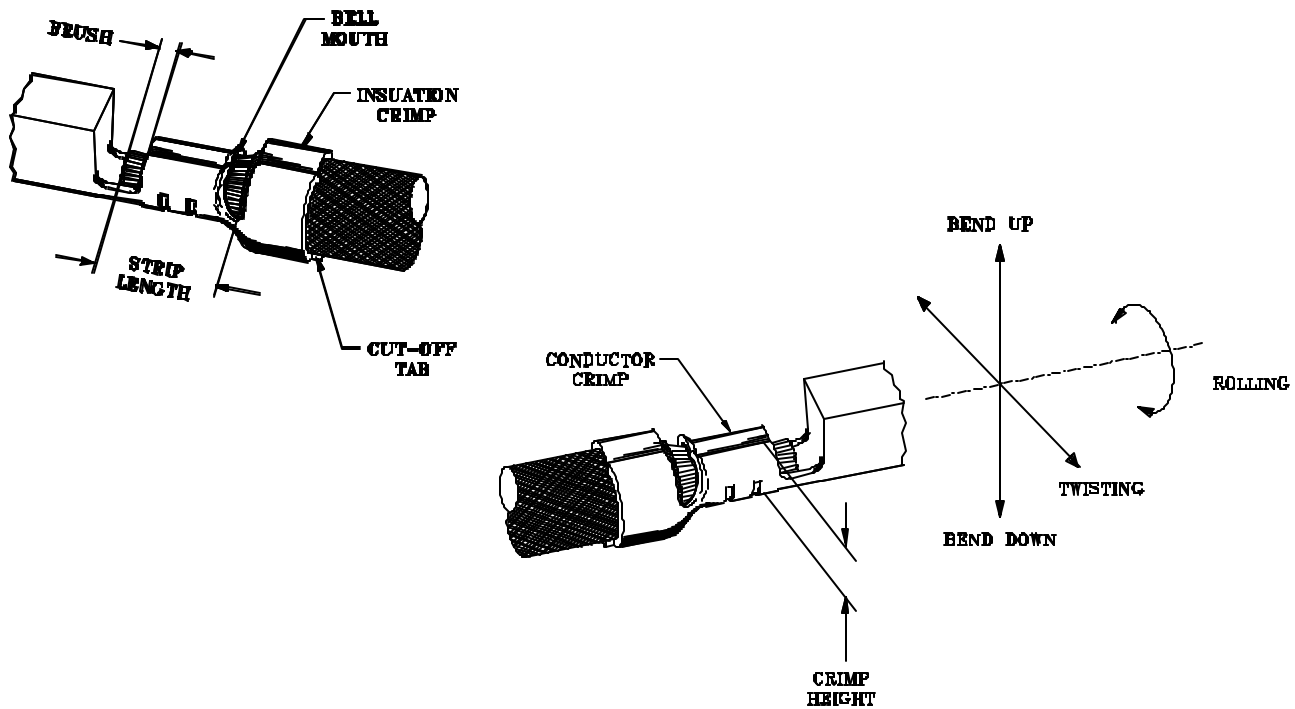

The above terminal drawing is a generic terminal representation. It is not an image of a terminal listed in the scope

SPECIFICATIONS

Terminal Series No.	Bellmouth mm (in)	Cut-Off Tab Max. mm (in)	Conductor Brush mm (in)
33012-1003	0.25-1.25 (.010-.049)	0.50 (.020)	0.15-0.65 (.006-.026)
33001-1005	0.25-1.25 (.010-.049)	0.50 (.020)	0.15-0.65 (.006-.026)

Terminal Series No.	Bend Up Degree	Bend Down Degree	Twist Degree	Roll	Punch Width mm Conductor Insulation
33012-1003	3	3	3	5	1.40 1.75
33001-1005	3	3	3	5	1.40 1.75

The above specifications are guidelines to an optimum crimp.

CONDITIONS

After crimping, the crimp profiles should measure the following.

Terminal Series	Wire Size Awg (mm ²)	Conductor Crimp Height mm (in)	Conductor Crimp Width mm (in)	Pull Force Min N (lbs)
33012-1003	22 (0.36)	0.90-1.00 (.035-.039)	1.35-1.55 (.053-.061)	50.0 (11.25)
33001-1005	22 (0.36)	0.90-1.00 (.035-.039)	1.35-1.55 (.053-.061)	50.0 (11.25)

Terminal Series	Wire Size Awg (mm ²)	Insulation Crimp Height mm (in)	Insulation Crimp Width mm (in)
33012-1003	22 (0.36)	1.50-1.70 (.059-.067)	1.70-1.90 (.067-.075)
33001-1005	22 (0.36)	1.50-1.70 (.059-.067)	1.70-1.90 (.067-.075)

Pull Force measured with no influence from the insulation crimp

PARTS LIST

Item Number	Order Number	Eng Number	Description	Qty	Kit Part
1	634570008	634570008	Conductor Punch	1	Y
2	634550011	634550011	Conductor Anvil	1	Y
3	634540018	634540018	Insulation Punch	1	Y
4	634560017	634560017	Insulation Anvil	1	Y
5	634610001	634610001	Cut-Off Plunger	1	Y
6	634430036	634430036	Front Plunger Retainer	1	Y
7	637000539	637000539	Cut-Off Plunger Spring	1	
8	634433160	634433160	Front Plunger Striker	1	
9	634430021	634430021	Lower Tooling Key	1	
10	634436004	634436004	Rear Cover	1	
11	11-18-4094	60709A111	Front Cover	1	
12	634432506	634432506	Anvil Mount	1	
13	11-18-4080	60707-5	Wire Stop	1	
14	634430009	634430009	Scrap Chute	1	
15	638013100	638013100	Wide Track FineAdjust	1	
49	634590001	634590001	Wide Terminal Track	1	
70	638654170	638654170	Tool Kit (All "Y" Items)	0	

NOTES

1. We recommend an extra perishable tooling kit be maintained at your facility.
2. Verify tooling alignment by manually cycling the press and Applicator before crimping under power.
3. Slugs , Terminals, Dirt and Oil should be kept clear of work area.
4. This Applicator should only be used in a press with a shut height of 135.8 mm (5.346"). Tooling damage could result at a lower setting.
5. **** CAUTION**** To prevent injury never operate this Applicator without the guarding supplied with the press or wire processing machine in place. Reference the press or wire processing manufacturer's instruction manual.
6. Wear safety glasses at all times.

ASSEMBLY DRAWING

The drawing below is a generic drawing representation. Some detail may not be shown. The FineAdjust applicator assembly and parts list can be found in the FineAdjust manual.

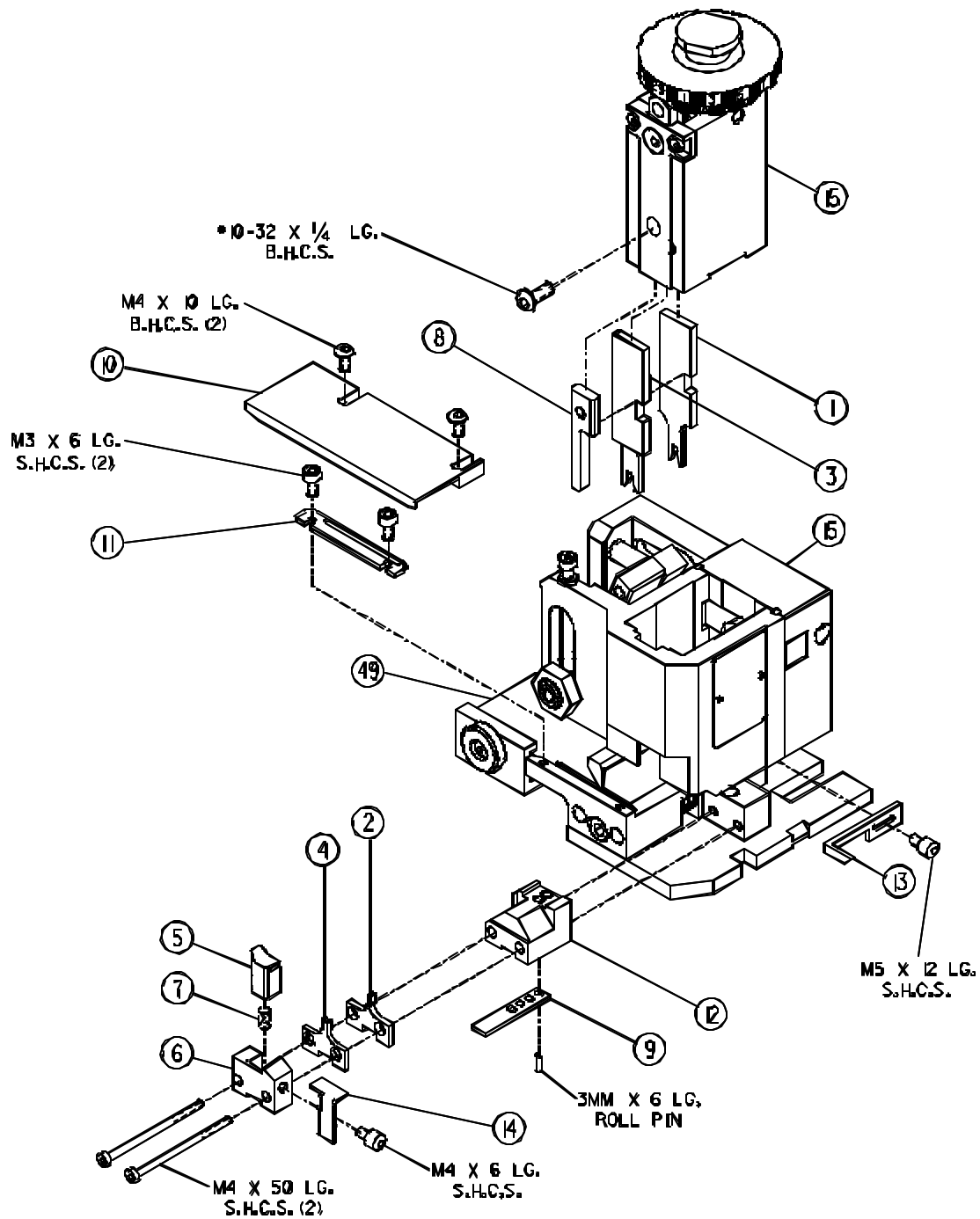

Mouser Electronics

Authorized Distributor

Click to View Pricing, Inventory, Delivery & Lifecycle Information:

[Molex:](#)

[63865-4170](#)