

PROPER USE GUIDELINES

Cumulative Trauma Disorders can result from the prolonged use of manually powered hand tools. Hand tools are intended for occasional use and low volume applications. A wide selection of powered application equipment for extended-use, production operations is available.

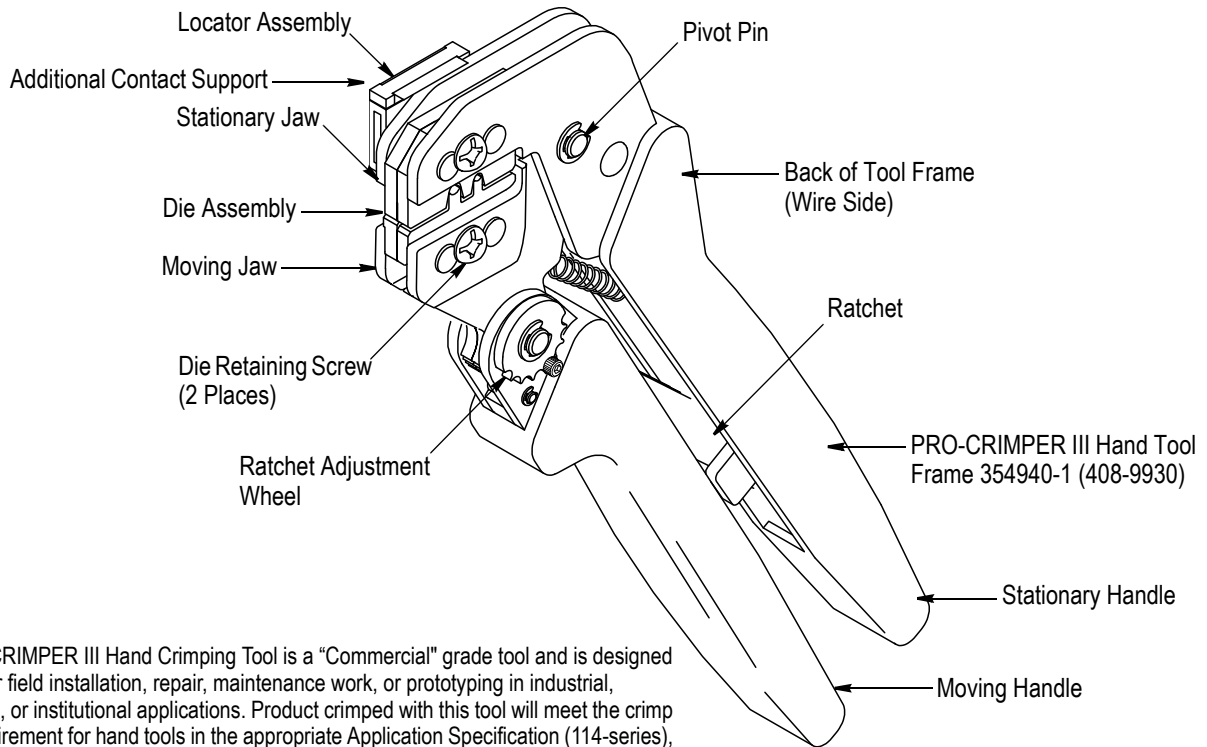

The PRO-CRIMPER III Hand Crimping Tool is a "Commercial" grade tool and is designed primarily for field installation, repair, maintenance work, or prototyping in industrial, commercial, or institutional applications. Product crimped with this tool will meet the crimp height requirement for hand tools in the appropriate Application Specification (114-series), but may not comply with other feature parameters of the specification.

TE Connectivity offers a variety of tools to satisfy your performance requirements. For additional information, contact the Tooling Assistance Center at 1-800-722-1111.

DIE ASSEMBLY	LOCATOR ASSEMBLY ‡	ADDITIONAL CONTACT SUPPORT †	PRODUCT FAMILY	WIRE		
				SIZE (mm [in.])	INSULATION DIAMETER (mm [in.])	STRIP LENGTH (mm [in.])
91387-2	58516-1	679277-1	4.2 mm Contact System	26-22	1.19-1.75 [.047-.069]	2.79-3.30 [.110-.130]

‡ Included with die assembly and available separately. † Included with tool assembly and available separately.

Figure 1

1. INTRODUCTION

PRO-CRIMPER III Hand Tool Assembly 91387-1 consists of PRO-CRIMPER III Hand Tool Frame 354940-1 and Die Assembly 91387-2. The tool assembly is used to crimp the contacts listed in Figure 1. For contact part numbers, contact **PRODUCT INFORMATION** at the number at the bottom of this page.

Read these instructions thoroughly before using the tool assembly.

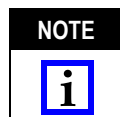

Dimensions in this instruction sheet are in metric units [with U.S. customary units in brackets]. Figures are not drawn to scale.

For additional information on the hand tool frame, refer to 408-9930.

Reasons for reissue of this instruction sheet are provided in Section 9, REVISION SUMMARY.

2. DESCRIPTION (See Figure 1)

The tool consist of a stationary jaw and handle, a moving jaw and handle, and an adjustable ratchet that ensures full crimping. The tool features a ratchet adjustment wheel for adjusting the crimp height.

The die assembly consists of a wire anvil, insulation anvil, wire crimper, and insulation crimper. When closed, the dies form two crimping chambers. Each die is held in the tool frame by a single screw.

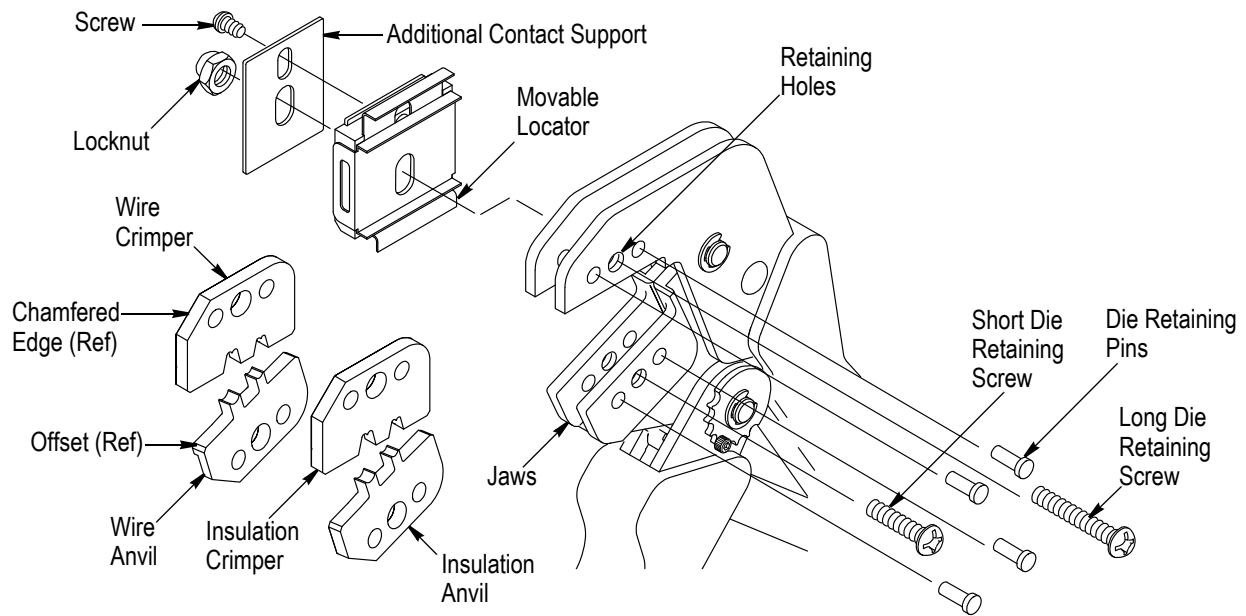

Figure 2

Attached to the outside of the tool frame is a locator assembly, which includes a locknut and moveable locator. An additional contact support is secured to the locator assembly by a screw. A nut is used on a die retaining screw to hold the locator assembly in place.

3. INSTALLATION AND REMOVAL OF DIE ASSEMBLY AND LOCATOR ASSEMBLY

1. Close the tool handles until the ratchet releases, then allow the handles to open fully. Remove the two die retaining screws from the tool jaws.
2. Place the wire anvil and insulation anvil with the chamfered edges and marked surfaces facing outward in the moving jaw of the tool frame as shown in Figure 2, and align the retaining holes in each die with the associated hole in the tool.
3. Insert two die retaining pins into the holes in the tool and through the holes in the anvils.
4. Insert the short die retaining screw through the jaw and through both anvil dies, and tighten the screw just enough to hold the dies in place. *Do not* tighten the screw completely at this time.
5. Place the wire crimper and insulation crimper with the chamfered edges and marked surfaces facing outward in the stationary jaw of the tool frame as shown in Figure 2, and align the retaining holes in each die with the associated hole in the tool.
6. Insert two die retaining pins into the holes in the tool and through the holes in the crimpers.
7. Insert the long die retaining screw through the jaw and through both crimper dies, and tighten the screw just enough to hold the dies in place. *Do not* tighten the screw completely at this time.

8. Carefully close the tool handles, making sure that the anvils and crimpers align properly. Continue closing the tool handles until the ratchet has engaged sufficiently to hold the anvils and crimpers in place, then tighten both die retaining screws.

9. Place the locator assembly and the additional contact support over the end of the long screw, and position the locator assembly against the side of the tool jaw. Refer to Figure 2.

10. Place the nut onto the end of the long screw and tighten the nut enough to hold the locator assembly in place, while still allowing the locator to slide up and down.

11. To disassemble, close the tool handles until the ratchet releases, remove the nut, the locator assembly, the two die retaining screws, and the four die retaining pins, and slide the anvils and crimpers out of the tool jaws.

4. CRIMPING PROCEDURE

NOTE



The contact support is preset prior to shipment, but minor adjustment may be necessary as described in Paragraph 5.1, Contact Support Adjustment. Also, this tool is provided with a crimp adjustment feature. Refer to Paragraph 5.2, Ratchet Adjustment. Initially, the crimp height should be verified as specified in Section 6, CRIMP HEIGHT INSPECTION, before using the tool.

Refer to Figure 1, and select wire of the specified size and insulation diameter. Strip the wire to the length indicated, taking care not to nick or cut the wire strands. Identify the appropriate crimping chamber according to the wire size markings on the die assembly. Then proceed with the following.

1. Close the tool handles until the ratchet releases, then allow the handles to open FULLY.
2. Holding the contact by the mating end, insert the contact, insulation barrel first, through the front of the tool and into the appropriate crimping chamber.
3. Position the contact so that the open "U" of the insulation barrel faces the top of the tool. Place the contact up into the nest so that the movable locator drops into the slot in the contact. Refer to Figure 3. Butt the front end of the wire barrel against the movable locator.

CAUTION  Make sure that both sides of the insulation barrel are started evenly into the crimping chamber. Do not attempt to crimp an improperly positioned contact.

4. Hold the contact in position and squeeze the tool handles together until ratchet engages sufficiently to hold the contact in position. DO NOT deform the insulation barrel or wire barrel.
5. Insert stripped wire into the contact insulation barrel and wire barrel until it is butted against the wire stop as shown in Figure 3.
6. Holding the wire in place, squeeze tool handles together until the ratchet releases. Allow the tool handles to open, and remove the crimped contact.

NOTE  The crimped contact may stick in the crimping area, but can be easily removed by pushing downward on the top of the locator (see Figure 3).

7. Inspect the crimp according to Section 6, CRIMP HEIGHT INSPECTION.

CAUTION  DO NOT use defective or damaged contacts. Cut the contact from the wire and use a new contact.

5. ADJUSTMENTS

5.1. Contact Support Adjustment

1. Make a sample crimp and determine if the contact is straight, bending upward, or bending downward.
2. If the contact is bending upward or downward, loosen the screw that holds the contact supports onto the locator assembly. See Figure 3.
3. Place a contact with wire into the proper nest and close the tool handles until the ratchet reaches the sixth click or until the additional contact support touches the contact.

NOTE  The ratchet has detents that create audible clicks as the tool handles are closed.

4. Slightly loosen the nut that holds the locator assembly onto the tool frame.
5. Move the contact support and secondary contact support as required to meet the dimensions given in Figure 3.
6. Tighten the nut, and close the handles until the ratchet releases.
7. Remove and inspect the contact. Make another sample crimp. If the contact is straight, tighten the screw. If the contact is still being bent during crimping, repeat the adjustment procedure.

5.2. Ratchet Adjustment

The tool ratchet mechanism features an adjustment wheel with numbered settings. The adjustment wheel controls the amount of handle pressure exerted on the jaws during crimping. If the crimp is not acceptable, adjust the ratchet as follows.

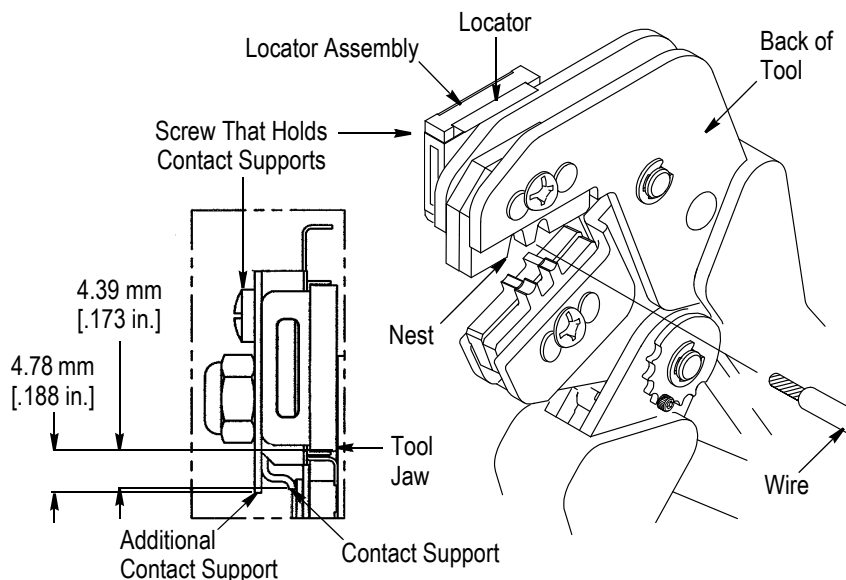
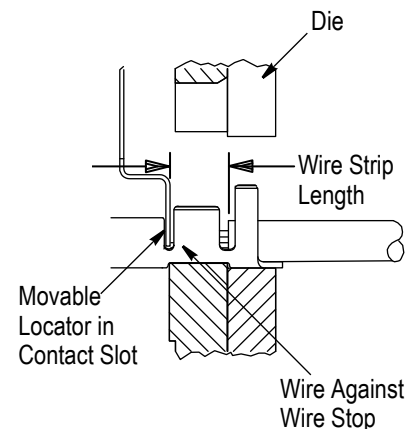

Figure 3



1. Remove the lock screw from the ratchet adjustment wheel. Refer to Figure 4.
2. Using a screwdriver, adjust the ratchet wheel from the front of the tool.
3. Observe the ratchet adjustment wheel. If a tighter crimp is required, rotate the adjustment wheel *counterclockwise* to a higher-numbered setting. If a looser crimp is required, rotate the adjustment wheel *clockwise* to a lower-numbered setting.
4. Re-install the lock screw.

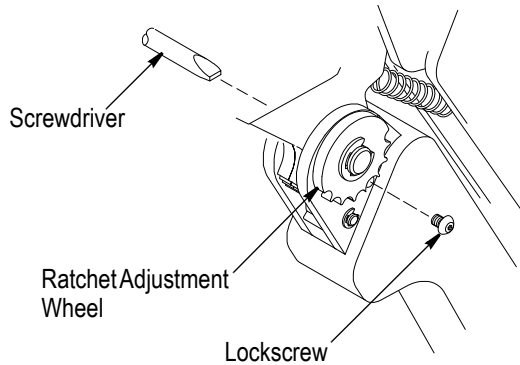

Figure 4

5. Make a sample crimp. If the crimp is acceptable, the adjustment setting is correct. If the crimp is unacceptable, continue to adjust the ratchet, and again measure a sample crimp.

6. CRIMP HEIGHT INSPECTION

Crimp height inspection is performed using a micrometer with a modified anvil, commonly referred to as a crimp height comparator. Refer to instruction sheet 408-7424 for detailed information on obtaining and using a crimp height comparator. Proceed as follows:

1. Refer to Figure 5 and select a maximum size wire for each crimping chamber.
2. Crimp the contacts according to Section 3, CRIMPING PROCEDURE.
3. Using the crimp height comparator, measure the wire barrel crimp height as shown in Figure 5. If the crimp height conforms to the dimension given, the tool is considered dimensionally correct. If not, the tool must be adjusted according to Paragraph 5.2, Ratchet Adjustment.

7. MAINTENANCE AND INSPECTION

7.1. Maintenance

1. Ensure that the tool frame and dies are clean by wiping them with a clean, soft cloth. Remove any debris with a clean, soft brush. Do not use objects that could damage any components.

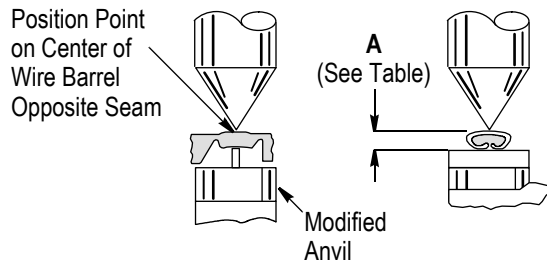

DIE ASSEMBLY	MAXIMUM WIRE SIZE (AWG)	CRIMPING CHAMBER (Wire Size Marking)	DIMENSION A (mm [in.]) CRIMP HEIGHT ±0.051 [±.002]
91387-2	24	26-24	0.79 [.031]
	22	22	0.89 [.035]

Figure 5

2. When not in use, keep tool handles closed to prevent objects from becoming lodged in the dies, and store in a clean, dry area.
3. Remove all lubrication and accumulated film from the dies by immersing the dies in a suitable commercial degreaser.

7.2. Visual Inspection

1. Inspection of the tool and dies should be made on a regular basis to ensure that they have not become worn or damaged.
2. Make sure that the proper die retaining screws are properly secured.
3. Inspect the crimping chambers of the die assembly for flattened, chipped, worn, or broken areas. If damage or abnormal wear is evident, the dies must be replaced. Refer to Section 8.

8. REPLACEMENT AND REPAIR

Customer-replaceable parts are shown in Figure 1. Available separately, Repair Kit 679221-1 includes a replacement nut and a variety of pins, rings, screws, and springs. If the dies are damaged or worn excessively, they must be replaced.

Order the repair kit, tool assembly, and die assembly through your representative, or call 1-800-526-5142, or send a facsimile of your purchase order to 717-986-7605, or write to:

CUSTOMER SERVICE (038-035)
 TYCO ELECTRONICS CORPORATION
 PO BOX 3608
 HARRISBURG PA 17105-3608

9. REVISION SUMMARY

Revisions to this instruction sheet include:

- Changed company name and logo

- Corrected locator assembly part number and added part number and clarity for additional contact support

- Updated tooling on last page

Tooling Compatible with Die Assembly 91387-2

PRO-CRIMPER III Hand Tool Frame 354940-1
(Instruction Sheet 408-9930)

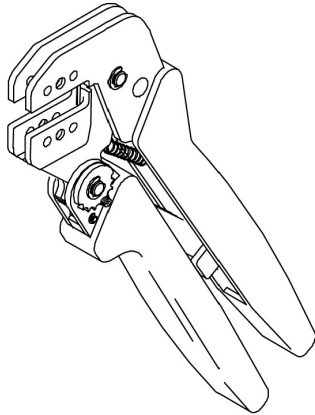

SDE-SA Hand Tool 9-1478240-0
(Instruction Sheet 408-8851)

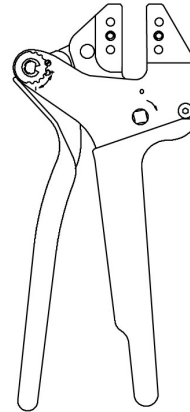

SDE Bench Terminator 1490076-2
(Customer Manual 409-10052)



626 Adapter 679304-1
(Instruction Sheet 408-4070)

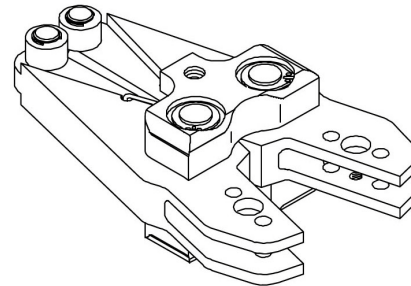

**Electro-Hydraulic (BT 3500 Battery-Hydraulic)
Hand Tool Kits 2031400-[]**
(Customer Manual 409-10095)

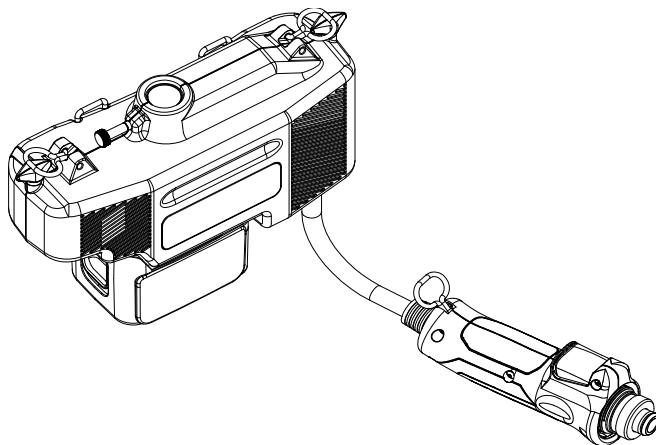

Closed Head Assembly 2031460-1
(Instruction Sheet 408-10312)

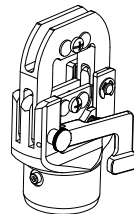

“C”-Head Assembly 2031450-1
(Instruction Sheet 408-10311)

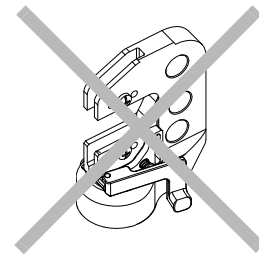

Mouser Electronics

Authorized Distributor

Click to View Pricing, Inventory, Delivery & Lifecycle Information:

[TE Connectivity:](#)

[91387-1](#)