



Smart Highside Power Switch

Features

- Load dump and reverse battery protection¹⁾
- Clamp of negative voltage at output
- Short-circuit protection
- Current limitation
- Thermal shutdown
- Diagnostic feedback
- Open load detection in ON-state
- CMOS compatible input
- **Electrostatic discharge (ESD)** protection
- Loss of ground and loss of V_{bb} protection²⁾
- Overvoltage protection
- Undervoltage and overvoltage shutdown with auto-restart and hysteresis
- Green Product (RoHS compliant)
- AEC qualified

Application

- μ C compatible power switch with diagnostic feedback for 12 V and 24 V DC grounded loads
- All types of resistive, inductive and capacitive loads
- Replaces electromechanical relays and discrete circuits

General Description

N channel vertical power FET with charge pump, ground referenced CMOS compatible input and diagnostic feedback, integrated in Smart SIPMOS® chip on chip technology. Providing protective functions.

Product Summary

$V_{Load\ dump}$	80	V
$V_{bb} - V_{OUT}$ Avalanche Clamp	58	V
V_{bb} (operation)	4.5 ... 42	V
V_{bb} (reverse)	-32	V
R_{ON}	38	m Ω
$I_L(SCp)$	44	A
$I_L(SCr)$	35	A
$I_L(ISO)$	11	A

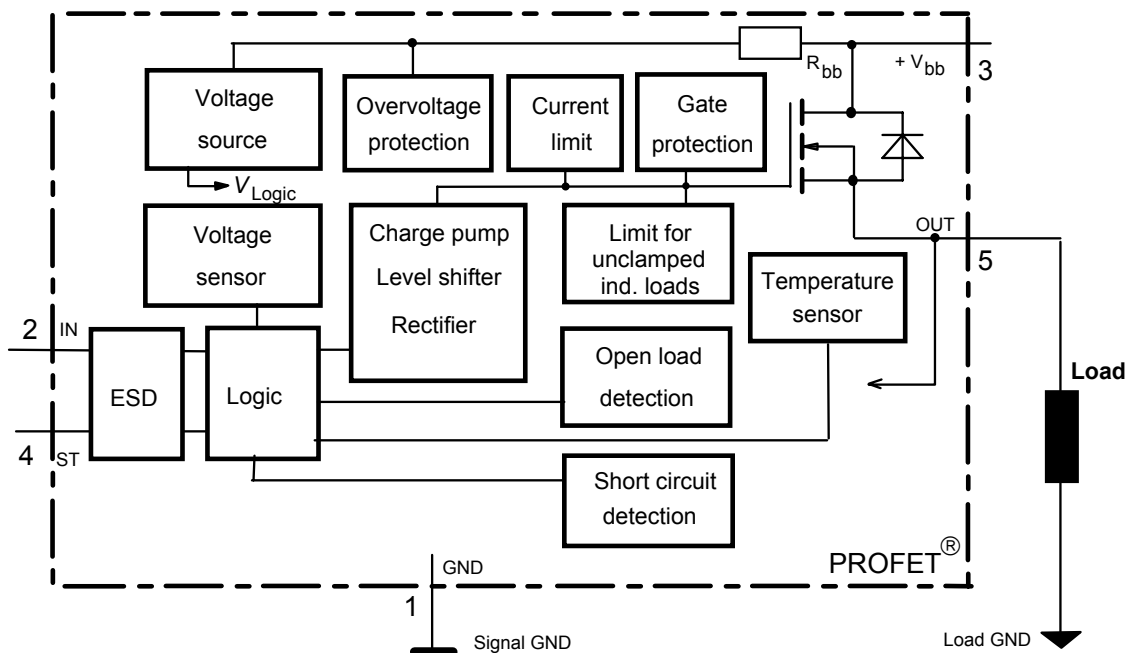
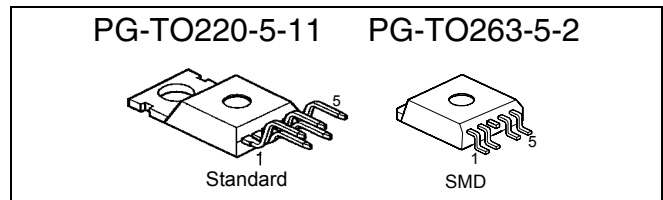

1) No external components required, reverse load current limited by connected load.

2) Additional external diode required for charged inductive loads

Pin	Symbol	Function
1	GND	Logic ground
2	IN	Input, activates the power switch in case of logical high signal
3	V _{bb}	Positive power supply voltage, the tab is shorted to this pin
4	ST	Diagnostic feedback, low on failure
5	OUT (Load, L)	Output to the load

Maximum Ratings at $T_j = 25\text{ °C}$ unless otherwise specified

Parameter	Symbol	Values	Unit
Supply voltage (overvoltage protection see page 3)	V_{bb}	63	V
Load dump protection $V_{LoadDump} = U_A + V_S$, $U_A = 13.5\text{ V}$ $R_I = 2\ \Omega$, $R_L = 1.1\ \Omega$, $t_d = 200\text{ ms}$, IN= low or high	$V_S^{3)}$	66.5	V
Load current (Short-circuit current, see page 4)	I_L	self-limited	A
Operating temperature range	T_j	-40 ... +150	°C
Storage temperature range	T_{stg}	-55 ... +150	
Power dissipation (DC)	P_{tot}	125	W
Inductive load switch-off energy dissipation, single pulse $T_j = 150\text{ °C}$:	E_{AS}	1.7	J
Electrostatic discharge capability (ESD) (Human Body Model)	V_{ESD}	2.0	kV
Input voltage (DC)	V_{IN}	-0.5 ... +6	V
Current through input pin (DC)	I_{IN}	± 5.0	mA
Current through status pin (DC)	I_{ST}	± 5.0	
see internal circuit diagrams page 6...			
Thermal resistance	chip - case: R_{thJC} junction - ambient (free air): R_{thJA} SMD version, device on pcb ⁴⁾ :	≤ 1 ≤ 75 typ. 33	K/W

3) V_S is setup without DUT connected to the generator per ISO 7637-1 and DIN 40839

4) Device on 50mm*50mm*1.5mm epoxy PCB FR4 with 6cm² (one layer, 70µm thick) copper area for V_{bb} connection. PCB is vertical without blown air.

Electrical Characteristics

Parameter and Conditions at $T_j = 25\text{ °C}$, $V_{bb} = 12\text{ V}$ unless otherwise specified	Symbol	Values			Unit
		min	typ	max	

Load Switching Capabilities and Characteristics

On-state resistance (pin 3 to 5) $I_L = 2\text{ A}$	$T_j = 25\text{ °C}$: $T_j = 150\text{ °C}$:	R_{ON}	--	30 55	38 70	$m\Omega$
Nominal load current (pin 3 to 5) ISO Proposal: $V_{ON} = 0.5\text{ V}$, $T_C = 85\text{ °C}$		$I_{L(ISO)}$	9	11	--	A
Output current (pin 5) while GND disconnected or GND pulled up, $V_{IN} = 0$, see diagram page 7, $T_j = -40\dots+150\text{ °C}$		$I_{L(GNDhigh)}$	--	--	1	mA
Turn-on time to 90% V_{OUT} :	t_{on}	50	160	300	μs	
Turn-off time to 10% V_{OUT} :	t_{off}	10	--	80		
$R_L = 12\ \Omega$, $T_j = -40\dots+150\text{ °C}$						
Slew rate on 10 to 30% V_{OUT} , $R_L = 12\ \Omega$, $T_j = -40\dots+150\text{ °C}$	dV/dt_{on}	0.4	--	2.5	$V/\mu s$	
Slew rate off 70 to 40% V_{OUT} , $R_L = 12\ \Omega$, $T_j = -40\dots+150\text{ °C}$	$-dV/dt_{off}$	1	--	5	$V/\mu s$	

Operating Parameters

Operating voltage ⁵⁾	$T_j = -40\dots+150\text{ °C}$:	$V_{bb(on)}$	4.5	--	42	V
Undervoltage shutdown	$T_j = -40\dots+150\text{ °C}$:	$V_{bb(under)}$	2.4	--	4.5	V
Undervoltage restart	$T_j = -40\dots+150\text{ °C}$:	$V_{bb(u\ rst)}$	--	--	4.5	V
Undervoltage restart of charge pump see diagram page 12	$T_j = -40\dots+150\text{ °C}$:	$V_{bb(ucp)}$	--	6.5	7.5	V
Undervoltage hysteresis $\Delta V_{bb(under)} = V_{bb(u\ rst)} - V_{bb(under)}$		$\Delta V_{bb(under)}$	--	0.2	--	V
Overvoltage shutdown	$T_j = -40\dots+150\text{ °C}$:	$V_{bb(over)}$	42	--	52	V
Overvoltage restart	$T_j = -40\dots+150\text{ °C}$:	$V_{bb(o\ rst)}$	42	--	--	V
Overvoltage hysteresis	$T_j = -40\dots+150\text{ °C}$:	$\Delta V_{bb(over)}$	--	0.2	--	V
Overvoltage protection ⁶⁾ $I_{bb} = 40\text{ mA}$	$T_j = -40\text{ °C}$: $T_j = 25\dots+150\text{ °C}$:	$V_{bb(AZ)}$	60 63	--	--	V
Standby current (pin 3) $V_{IN} = 0$	$T_j = -40\dots+25\text{ °C}$: $T_j = 150\text{ °C}$:	$I_{bb(off)}$	--	12 18	25 60	μA
Leakage output current (included in $I_{bb(off)}$) $V_{IN} = 0$		$I_{L(off)}$	--	6	--	μA
Operating current (Pin 1) ⁷⁾ , $V_{IN} = 5\text{ V}$		I_{GND}	--	1.1	--	mA

5) At supply voltage increase up to $V_{bb} = 6.5\text{ V}$ typ without charge pump, $V_{OUT} \approx V_{bb} - 2\text{ V}$

6) see also $V_{ON(CL)}$ in table of protection functions and circuit diagram page 7. Measured without load.

7) Add I_{ST} , if $I_{ST} > 0$, add I_{IN} , if $V_{IN} > 5.5\text{ V}$

Parameter and Conditions at $T_j = 25\text{ °C}$, $V_{bb} = 12\text{ V}$ unless otherwise specified	Symbol	Values			Unit
		min	typ	max	
Protection Functions⁸⁾					
Initial peak short circuit current limit (pin 3 to 5) ⁹⁾ , (max 400 μs if $V_{ON} > V_{ON(SC)}$)	$I_{L(SCp)}$				
$T_j = -40\text{ °C}$:		--	--	74	A
$T_j = 25\text{ °C}$:		--	44	--	
$T_j = +150\text{ °C}$:		24	--	--	
Repetitive short circuit current limit $T_j = T_{jt}$ (see timing diagrams, page 10)	$I_{L(SCr)}$	22	35	--	A
Short circuit shutdown delay after input pos. slope $V_{ON} > V_{ON(SC)}$, $T_j = -40..+150\text{ °C}$: min value valid only, if input "low" time exceeds 30 μs	$t_{d(SC)}$	80	--	400	μs
Output clamp (inductive load switch off) at $V_{OUT} = V_{bb} - V_{ON(CL)}$, $I_L = 30\text{ mA}$	$V_{ON(CL)}$	--	58	--	V
Short circuit shutdown detection voltage (pin 3 to 5)	$V_{ON(SC)}$	--	8.3	--	V
Thermal overload trip temperature	T_{jt}	150	--	--	°C
Thermal hysteresis	ΔT_{jt}	--	10	--	K
Inductive load switch-off energy dissipation ¹⁰⁾ , $T_{j\text{ Start}} = 150\text{ °C}$, single pulse	E_{AS}	--	--	1.7	J
$V_{bb} = 12\text{ V}$:	E_{Load12}			1.3	
$V_{bb} = 24\text{ V}$:	E_{Load24}			1.0	
Reverse battery (pin 3 to 1) ¹¹⁾	$-V_{bb}$	--	--	32	V
Integrated resistor in V_{bb} line	R_{bb}	--	120	--	Ω

Diagnostic Characteristics

Open load detection current (on-condition)	$T_j = -40\text{ °C}$: $T_j = 25..150\text{ °C}$:	$I_L(OL)$	2 2	-- --	900 750	mA
---	--	-----------	--------	----------	------------	----



8) Integrated protection functions are designed to prevent IC destruction under fault conditions described in the data sheet. Fault conditions are considered as "outside" normal operating range. Protection functions are not designed for continuous repetitive operation.

9) Short circuit current limit for max. duration of 400 μs , prior to shutdown (see $t_{d(SC)}$ page 4)

10) While demagnetizing load inductance, dissipated energy in PROFET is $E_{AS} = \int V_{ON(CL)} * i_L(t) dt$, approx.

$$E_{AS} = \frac{1}{2} * L * I_L^2 * \left(\frac{V_{ON(CL)}}{V_{ON(CL)} - V_{bb}} \right), \text{ see diagram page 8.}$$

11) Reverse load current (through intrinsic drain-source diode) is normally limited by the connected load. Reverse current I_{GND} of $\approx 0.3\text{ A}$ at $V_{bb} = -32\text{ V}$ through the logic heats up the device. Time allowed under these condition is dependent on the size of the heatsink. Reverse I_{GND} can be reduced by an additional external GND-resistor (150 Ω). Input and Status currents have to be limited (see max. ratings page 2 and circuit page 7).

Parameter and Conditions at $T_j = 25\text{ °C}$, $V_{bb} = 12\text{ V}$ unless otherwise specified	Symbol	Values			Unit
		min	typ	max	
Input and Status Feedback¹²⁾					
Input turn-on threshold voltage  $T_j = -40..+150\text{ °C}$:	$V_{IN(T+)}$	1.5	--	2.4	V
Input turn-off threshold voltage  $T_j = -40..+150\text{ °C}$:	$V_{IN(T-)}$	1.0	--	--	V
Input threshold hysteresis	$\Delta V_{IN(T)}$	--	0.5	--	V
Off state input current (pin 2) $V_{IN} = 0.4\text{ V}$:	$I_{IN(off)}$	1	--	30	μA
On state input current (pin 2) $V_{IN} = 3.5\text{ V}$:	$I_{IN(on)}$	10	25	50	μA
Status invalid after positive input slope (short circuit) $T_j = -40 \dots +150\text{ °C}$:	$t_{d(ST\ SC)}$	80	200	400	μs
Status invalid after positive input slope (open load) $T_j = -40 \dots +150\text{ °C}$:	$t_{d(ST)}$	350	--	1600	μs
Status output (open drain) Zener limit voltage $T_j = -40\dots+150\text{ °C}$, $I_{ST} = +1.6\text{ mA}$:	$V_{ST(high)}$	5.4	6.1	--	V
ST low voltage $T_j = -40\dots+150\text{ °C}$, $I_{ST} = +1.6\text{ mA}$:	$V_{ST(low)}$	--	--	0.4	

¹²⁾ If a ground resistor R_{GND} is used, add the voltage drop across this resistor.

Truth Table

	Input-Level	Output level	Status
			432E2
Normal operation	L	L	H
	H	H	H
Open load	L	13)	H
	H	H	L
Short circuit to GND	L	L	H
	H	L	L
Short circuit to V _{bb}	L	H	H
	H	H	H (L ¹⁴)
Overtemperature	L	L	L
	H	L	L
Under-voltage	L	L	H
	H	L	H
Overvoltage	L	L	H
	H	L	H

L = "Low" Level
H = "High" Level

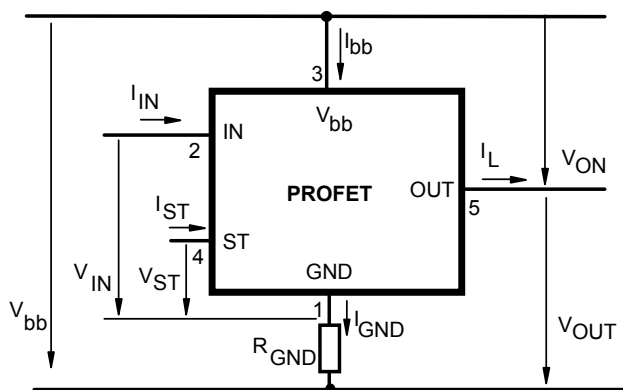
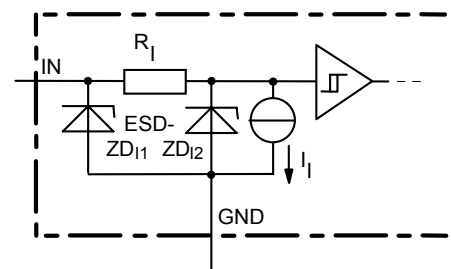
Terms

Input circuit (ESD protection)

ZD11 6.1 V typ., ESD zener diodes are not designed for continuous current

13) Power Transistor off, high impedance

14) Low resistance short V_{bb} to output may be detected by no-load-detection

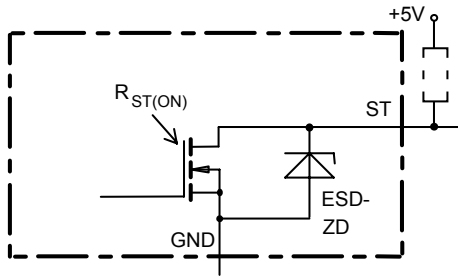
Status output



ESD-Zener diode: 6.1 V typ., max 5 mA;
 $R_{ST(ON)} < 250 \Omega$ at 1.6 mA, ESD zener diodes are not designed for continuous current

Short Circuit detection

Fault Condition: $V_{ON} > 8.3 V$ typ.; IN high

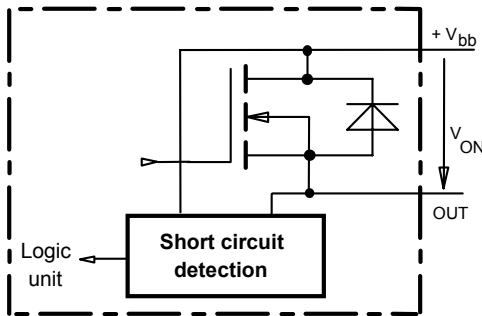

Inductive and overvoltage output clamp

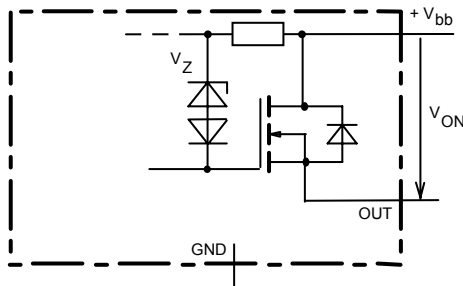

V_{ON} clamped to 58 V typ.

Overvolt. and reverse batt. protection

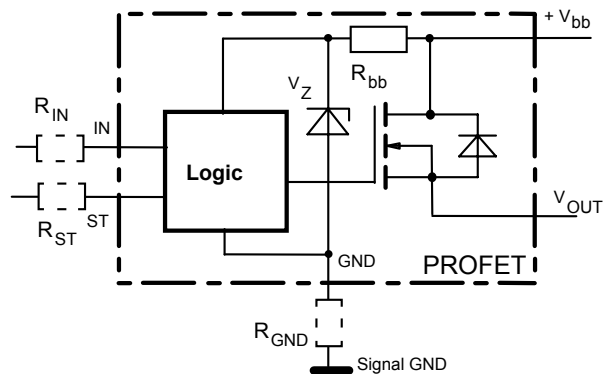

$R_{bb} = 120 \Omega$ typ., $V_Z + R_{bb} * 40 mA = 67 V$ typ., add R_{GND} , R_{IN} , R_{ST} for extended protection

Open-load detection

ON-state diagnostic condition: $V_{ON} < R_{ON} * I_{L(OL)}$; IN high

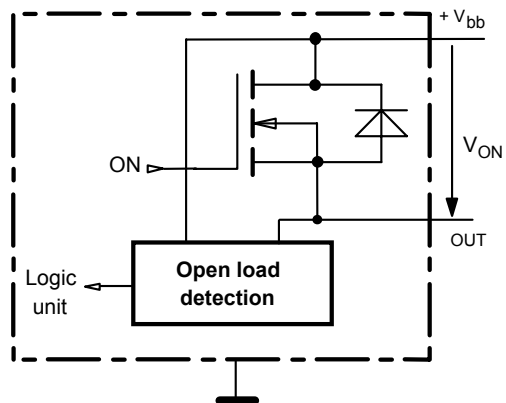

GND disconnect

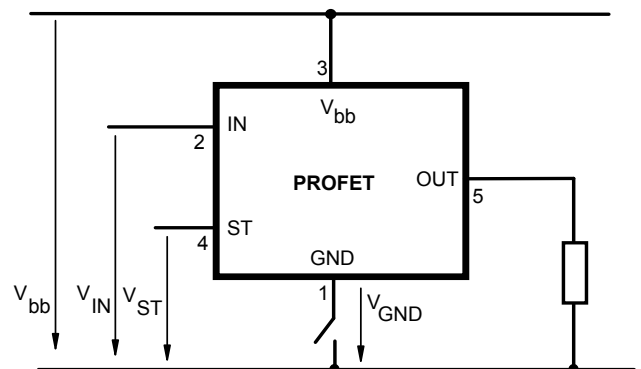

Any kind of load. In case of Input=high is $V_{OUT} \approx V_{IN} - V_{IN(T+)}$.
 Due to $V_{GND} > 0$, no $V_{ST} =$ low signal available.

GND disconnect with GND pull up

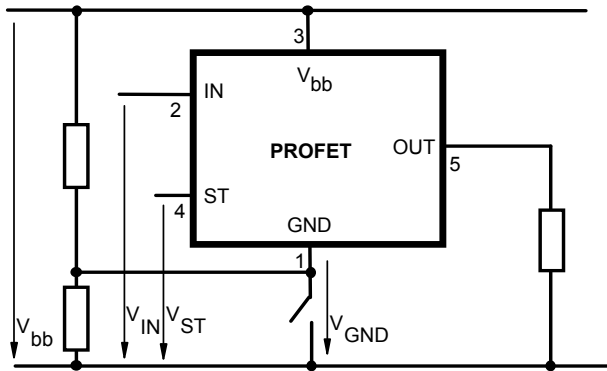

Any kind of load. If $V_{GND} > V_{IN} - V_{IN(T+)}$ device stays off
 Due to $V_{GND} > 0$, no $V_{ST} = \text{low}$ signal available.

V_{bb} disconnect with charged inductive load

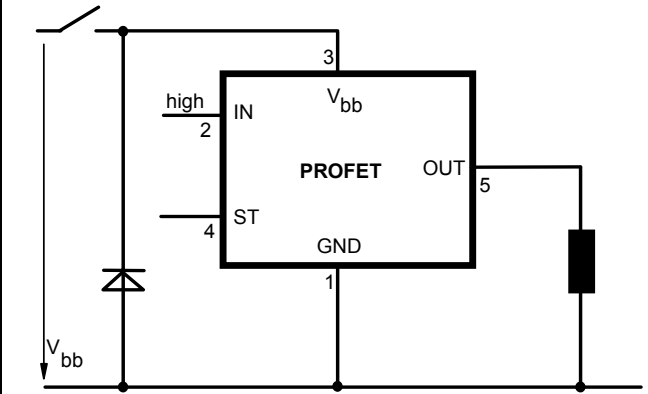
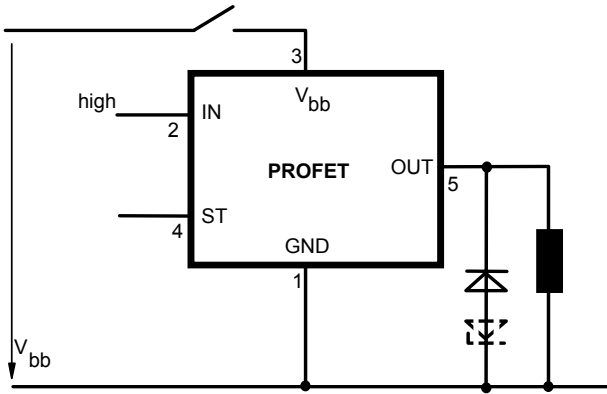

Inductive Load switch-off energy dissipation

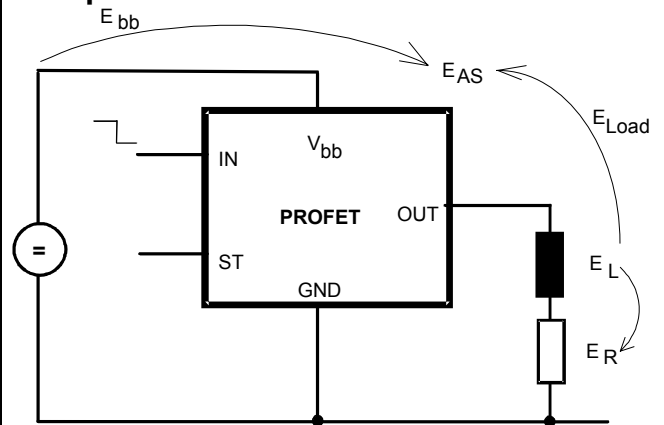

Energy dissipated in PROFET $E_{AS} = E_{bb} + E_L - E_R$.
 $E_{Load} < E_L$, $E_L = \frac{1}{2} * L * I_L^2$

Options Overview

all versions: High-side switch, Input protection, ESD protection, load dump and reverse battery protection , protection against loss of ground

Type	BTS	432E2
Logic version		E
Overtemperature protection $T_j > 150\text{ °C}$, latch function ¹⁵⁾¹⁶⁾ $T_j > 150\text{ °C}$, with auto-restart on cooling		X
Short-circuit to GND protection switches off when $V_{ON} > 8.3\text{ V typ.}^{15)}$ (when first turned on after approx. 200 μs)		X
Open load detection in OFF-state with sensing current 30 $\mu\text{A typ.}$ in ON-state with sensing voltage drop across power transistor		X
Undervoltage shutdown with auto restart		X
Overvoltage shutdown with auto restart		X
Status feedback for		
overtemperature		X
short circuit to GND		X
short to V_{bb}		- ¹⁷⁾
open load		X
undervoltage		-
overvoltage		-
Status output type		
CMOS		
Open drain		X
Output negative voltage transient limit (fast inductive load switch off) to $V_{bb} - V_{ON(CL)}$		X
Load current limit		
high level (can handle loads with high inrush currents)		X
medium level		
low level (better protection of application)		

¹⁵⁾ Latch except when $V_{bb} - V_{OUT} < V_{ON(SC)}$ after shutdown. In most cases $V_{OUT} = 0\text{ V}$ after shutdown ($V_{OUT} \neq 0\text{ V}$ only if forced externally). So the device remains latched unless $V_{bb} < V_{ON(SC)}$ (see page 4). No latch between turn on and $t_{d(SC)}$.

¹⁶⁾ With latch function. Reseted by a) Input low, b) Undervoltage, c) Overvoltage

¹⁷⁾ Low resistance short V_{bb} to output may be detected by no-load-detection

Timing diagrams

Figure 1a: V_{bb} turn on:

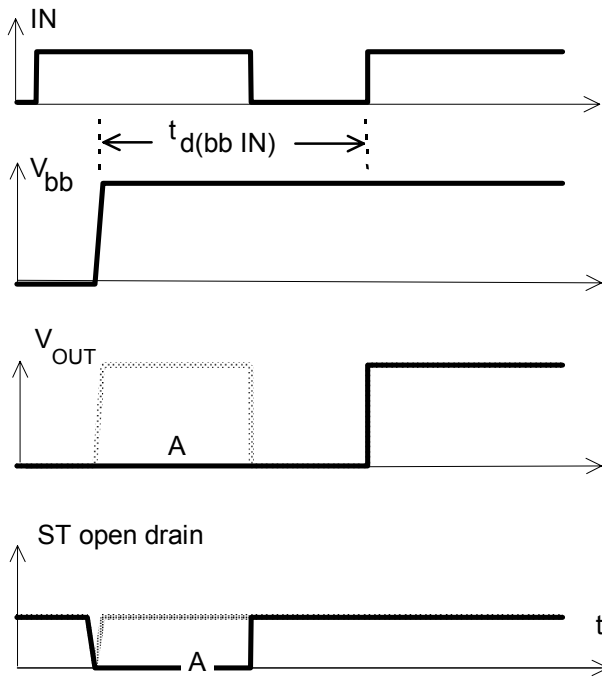

in case of too early V_{IN} =high the device may not turn on (curve A)
 $t_{d(bb IN)}$ approx. 150 μ s

Figure 2a: Switching a lamp,

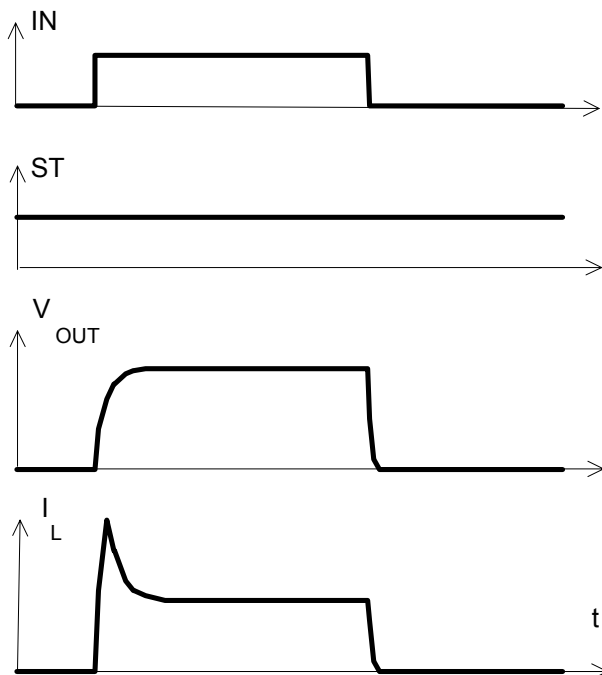
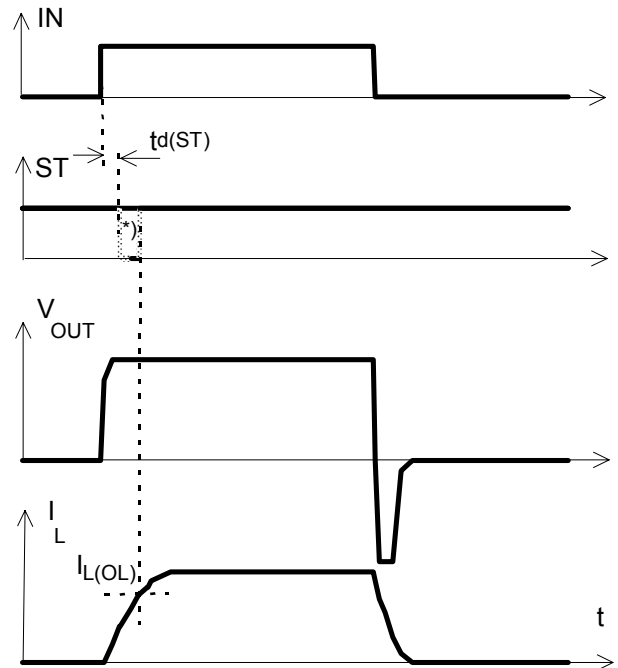
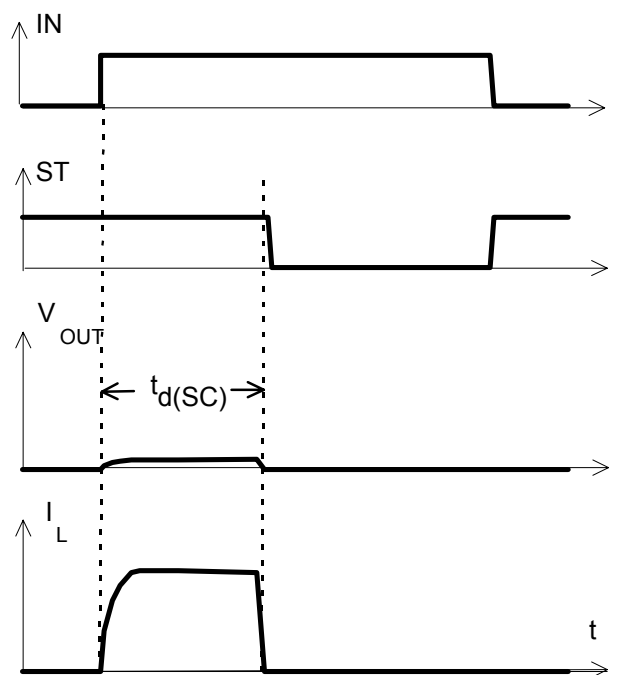

Figure 2b: Switching an inductive load



*) if the time constant of load is too large, open-load-status may occur

Figure 3a: Turn on into short circuit,



$t_{d(SC)}$ approx. 200 μ s if $V_{bb} - V_{OUT} > 8.3$ V typ.

Figure 3b: Turn on into overload,

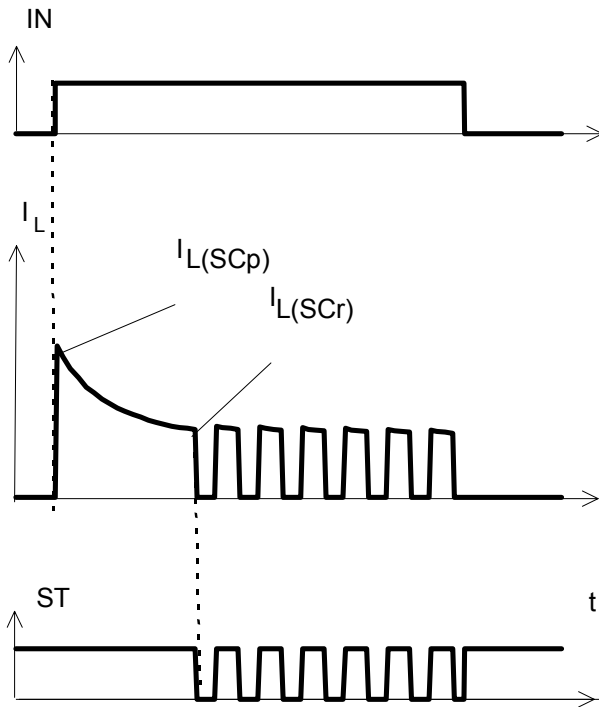

Heating up may require several milliseconds, $V_{bb} - V_{OUT} < 8.3\text{ V}$ typ.

Figure 3c: Short circuit while on:

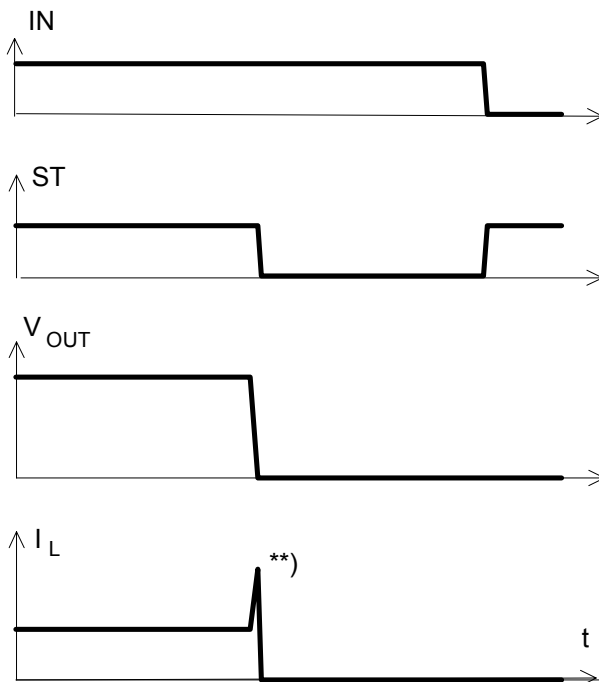

***) current peak approx. 20 μs

Figure 4a: Overtemperature:
Reset if $T_j < T_{jt}$

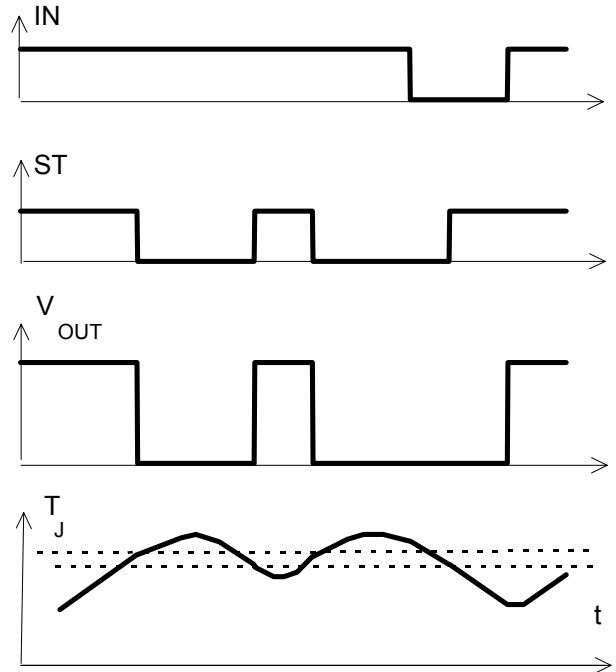

Figure 5a: Open load: detection in ON-state, turn on/off to open load

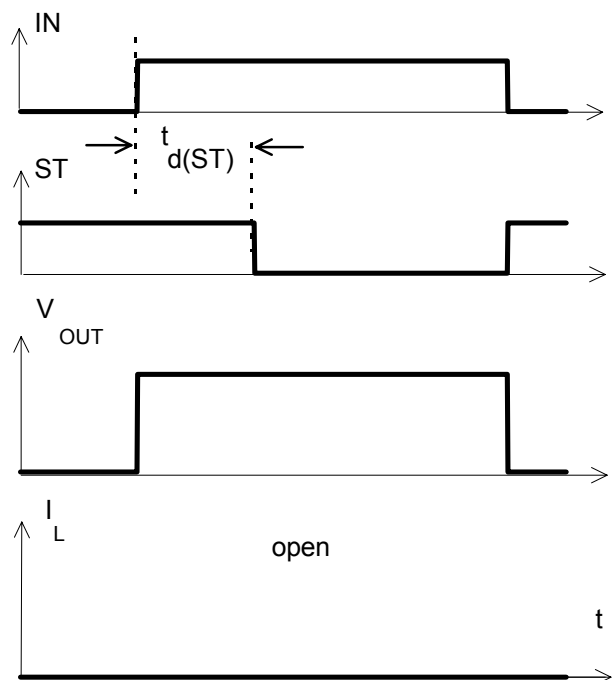

Figure 5b: Open load: detection in ON-state, open load occurs in on-state

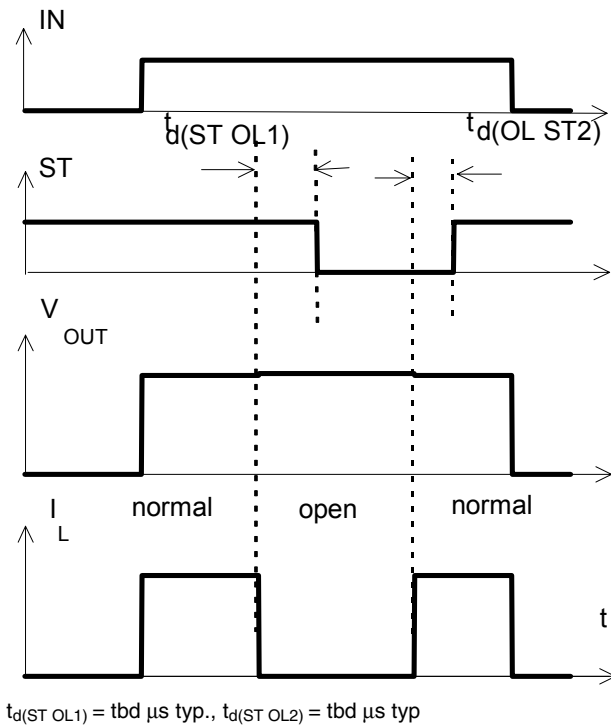

Figure 6a: Undervoltage:

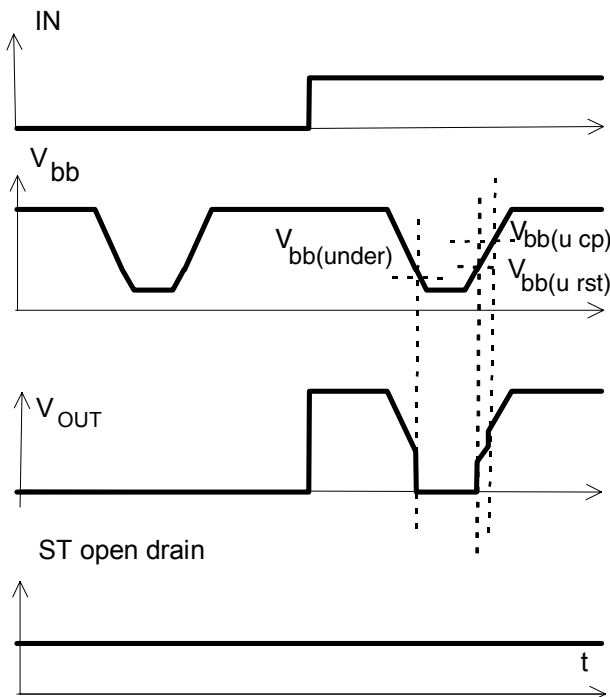

Figure 6b: Undervoltage restart of charge pump

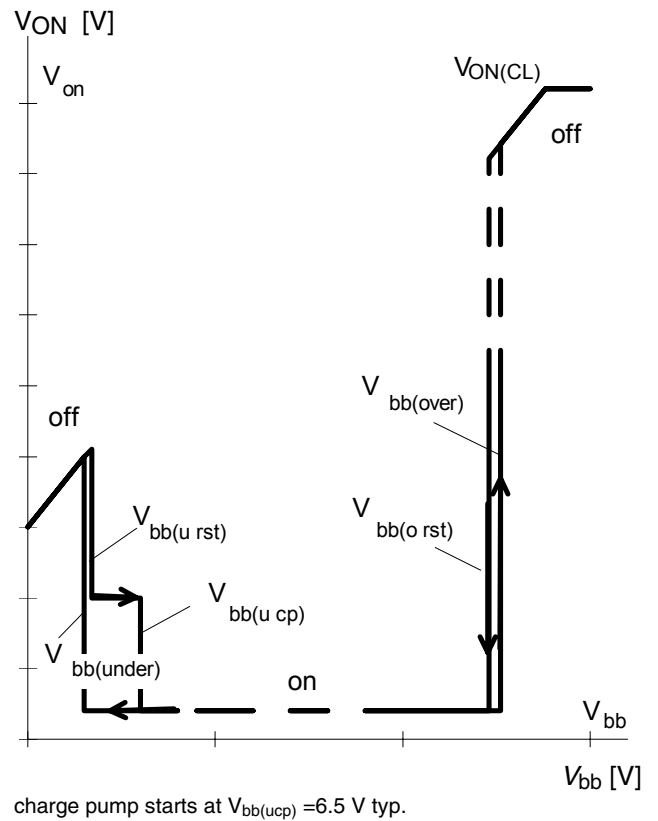
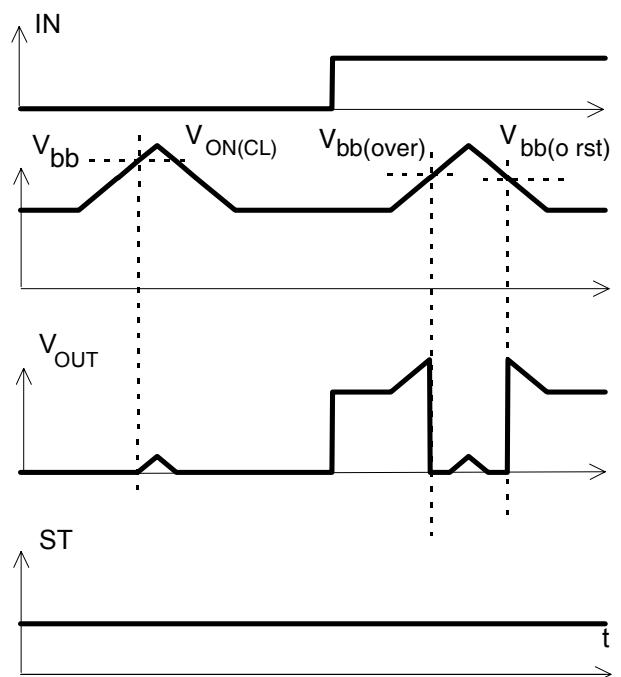

Figure 7a: Overvoltage:



Package and Ordering Code

All dimensions in mm

PG-TO220-5-11

BTS 432 E2

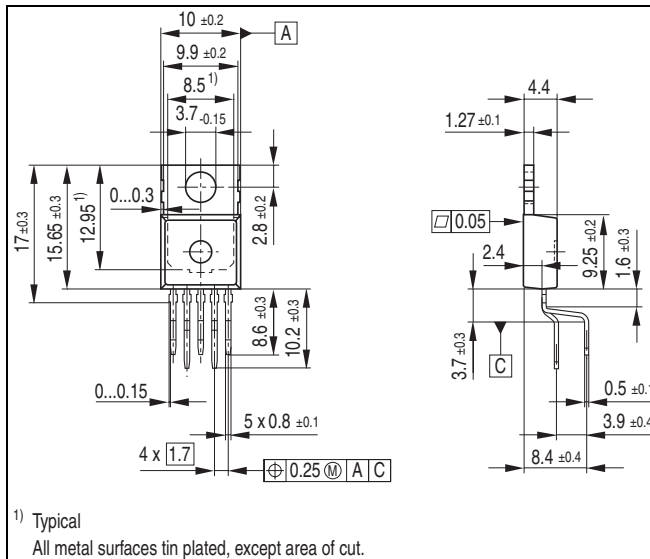

SMD PG-TO263-5-2

BTS432E2 E3062A

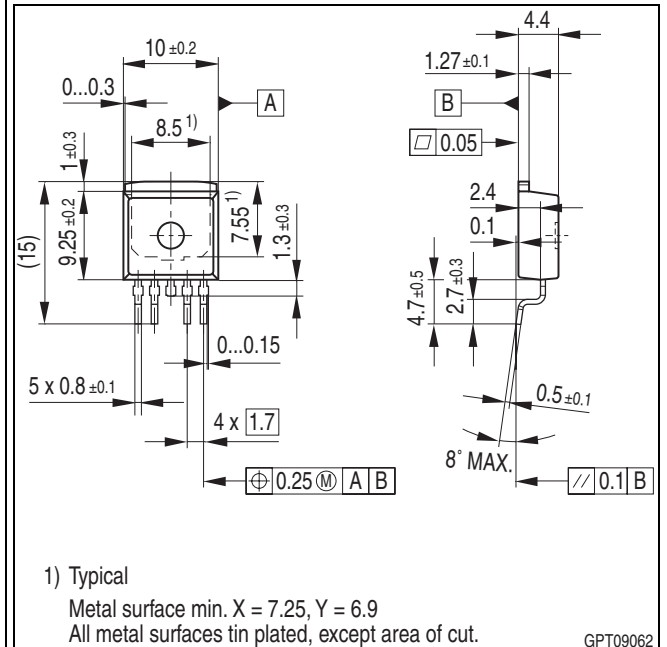

Green Product

To meet the world-wide customer requirements for environmentally friendly products and to be compliant with government regulations the device is available as a green product. Green products are RoHS-Compliant (i.e Pb-free finish on leads and suitable for Pb-free soldering according to IPC/JEDEC J-STD-020).

Revision History

Version	Date	Changes
Rev. 1.1	2010-01-26	Page 13: Package drawing for PG-TO220-5-11 corrected.
Rev. 1.0	2009-11-12	RoHS-compliant version of BTS432E2 Removal of straight lead package variant E3043 Page 1, page 13: RoHS compliance statement and Green product feature added Page 1, page 13: Change to RoHS compliant packages; PG-TO220-5-11 for standard (staggered) variant; PG-TO263-5-2 for E3062A variant. Page 2: Thermal resistance junction to ambient for SMD version set to typically 33K/W. Page 2: Pin marking removed. Page 6, 9: Discontinued variants removed from truth table & options overview. Legal disclaimer updated

Published by
Infineon Technologies AG
81726 Munich, Germany
© 2010 Infineon Technologies AG
All Rights Reserved.

Legal Disclaimer

The information given in this document shall in no event be regarded as a guarantee of conditions or characteristics. With respect to any examples or hints given herein, any typical values stated herein and/or any information regarding the application of the device, Infineon Technologies hereby disclaims any and all warranties and liabilities of any kind, including without limitation, warranties of non-infringement of intellectual property rights of any third party.

Information

For further information on technology, delivery terms and conditions and prices, please contact the nearest Infineon Technologies Office (www.infineon.com).

Warnings

Due to technical requirements, components may contain dangerous substances. For information on the types in question, please contact the nearest Infineon Technologies Office.

Infineon Technologies components may be used in life-support devices or systems only with the express written approval of Infineon Technologies, if a failure of such components can reasonably be expected to cause the failure of that life-support device or system or to affect the safety or effectiveness of that device or system. Life support devices or systems are intended to be implanted in the human body or to support and/or maintain and sustain and/or protect human life. If they fail, it is reasonable to assume that the health of the user or other persons may be endangered.

Mouser Electronics

Authorized Distributor

Click to View Pricing, Inventory, Delivery & Lifecycle Information:

[Infineon:](#)

[BTS432E2XK](#) [BTS432E2BKSA1](#)