

PART NAME: KNOB SCALE: 1:1 DATE: 7/18/90 DR. BY HD

THIS DRAWING IS THE PROPERTY OF DAVIES MOLDING COMPANY, IS SUBMITTED SOLELY AS A DESIGN OR ENGINEERING PROJECT. WE ACCEPT NO RESPONSIBILITY WHATSOEVER FOR THE PRACTICAL APPLICATION OF THE PIECES MADE TO THIS DESIGN.



DESIGNERS & MANUFACTURERS OF KNOBS, HANDLES, CASES & CUSTOM PLASTIC COMPONENTS

P/N	3070
M NO.	75
CAV.	3070
CORE	3070
CAV.PLUG	3070
SLEEVE	3070-M
PIN	2800
INSERT	10001

CAD/REDRAWN : 9/28/95 : HD

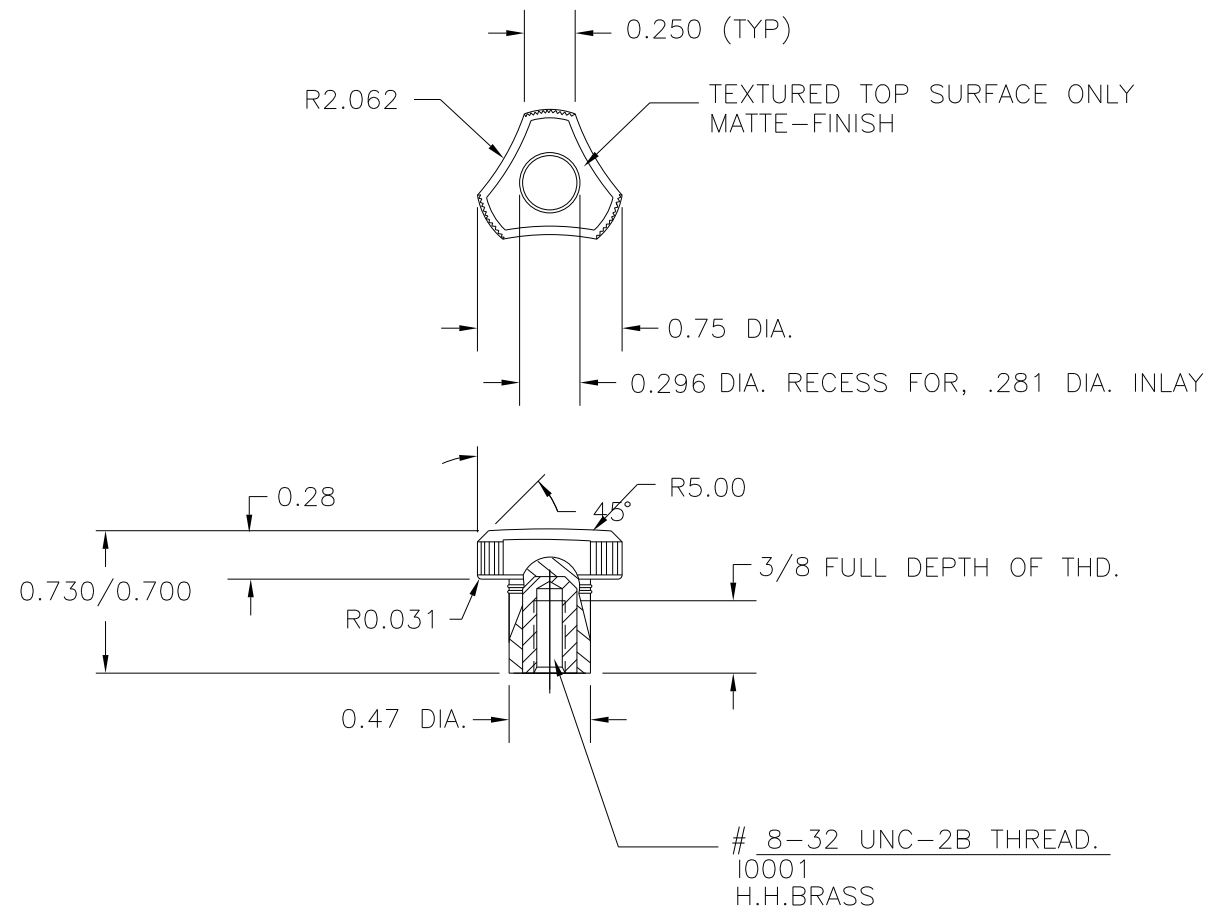

(A)

(B)

(C)

MATERIAL: NYLON 6/6 (ZY2), (ZY6)
OR ENGINEERING APPROVED EQUIVALENT
COLOR: BLACK

TOLERANCES: UNLESS OTHERWISE SPECIFIED	DO NOT SCALE DRAWING	C	ADDED ZY6	JAM	7/13/12
DECIMALS: X.XXX ± .005 X.XX ± .015	MM: X.XX ± 0.15MM X.X ± 0.4MM	B	ADDED MAT. CODE	JAM	12/28/06
FRACTIONS ± 1/64	ANG. ± 1°	A	WAS 2800-SLEEVES	HD	9/28/95
CHANGES					

Mouser Electronics

Authorized Distributor

Click to View Pricing, Inventory, Delivery & Lifecycle Information:

[Davies Molding:](#)

[3070](#)