

THIS DRAWING IS UNPUBLISHED. RELEASED FOR PUBLICATION 20
 © COPYRIGHT 20 BY - ALL RIGHTS RESERVED.

REVISIONS					
P	LTR	DESCRIPTION	DATE	DWN	APVD
	A1	REVISED PER ECR-17-015449	25OCT2017	BDA	KR

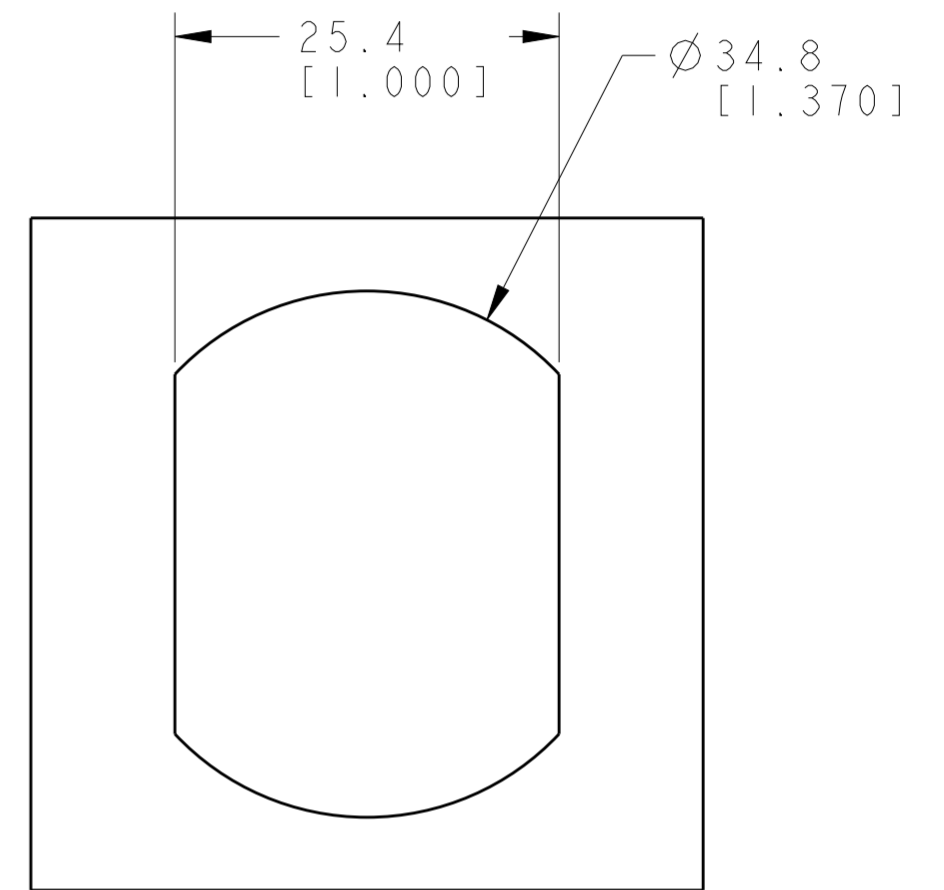

RECOMMENDED
 PANEL CUT-OUT
 SCALE 2:1

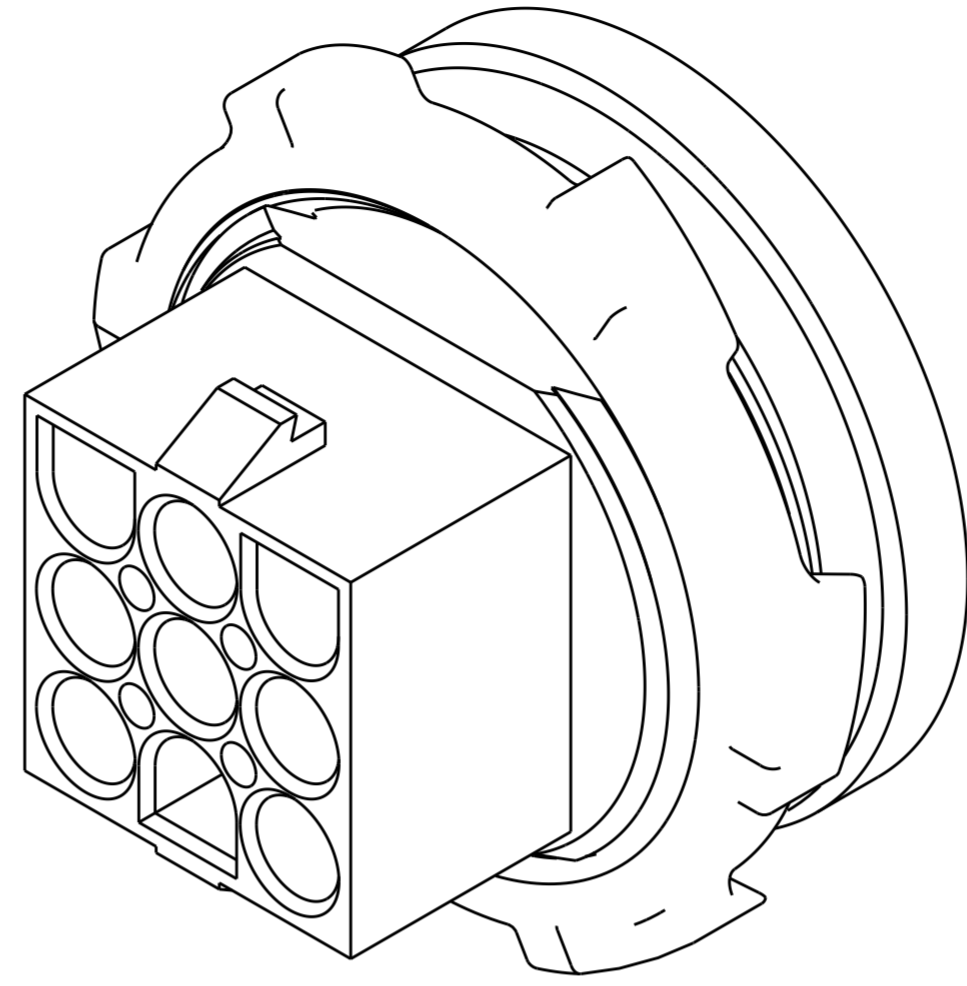
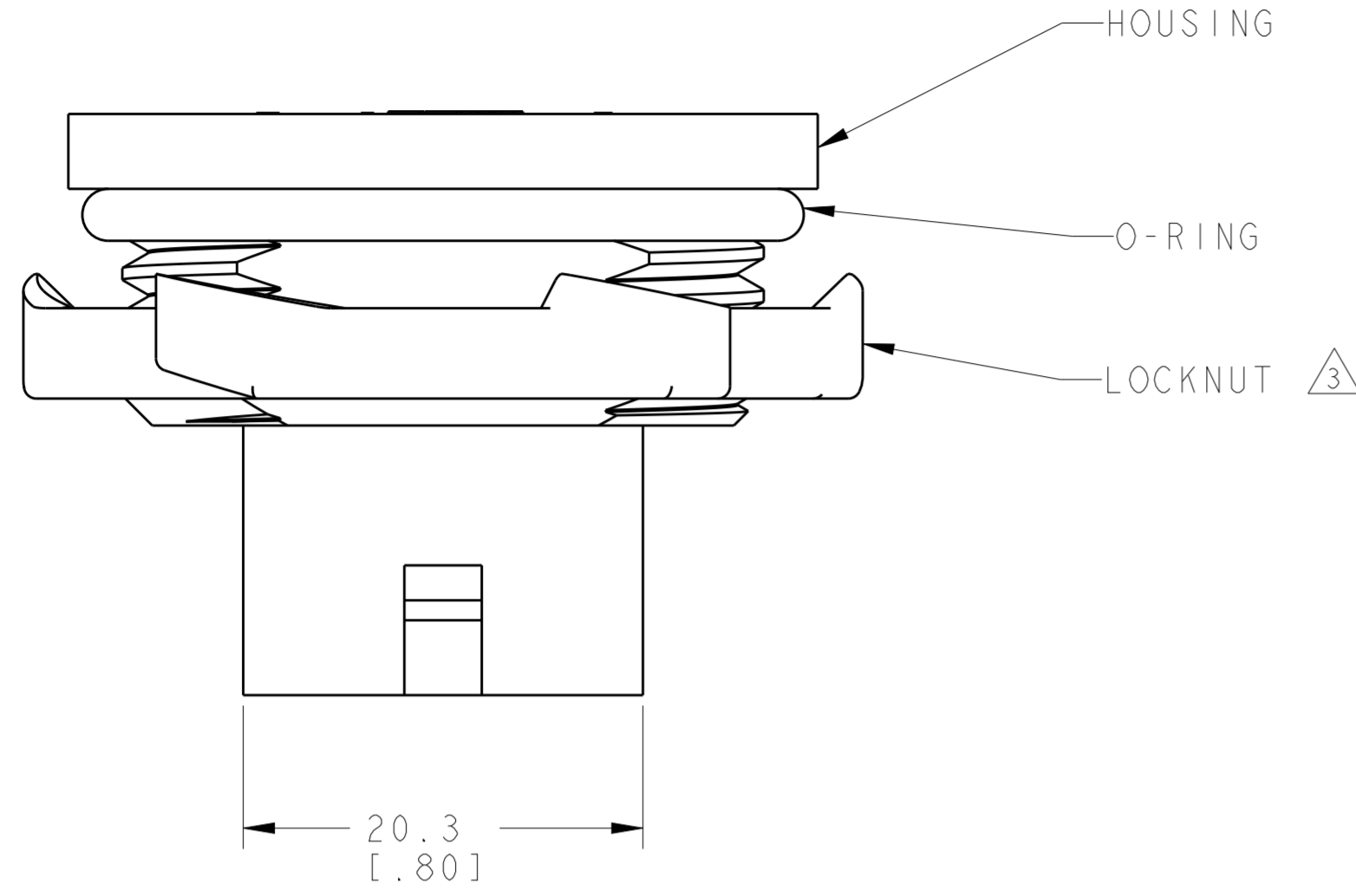
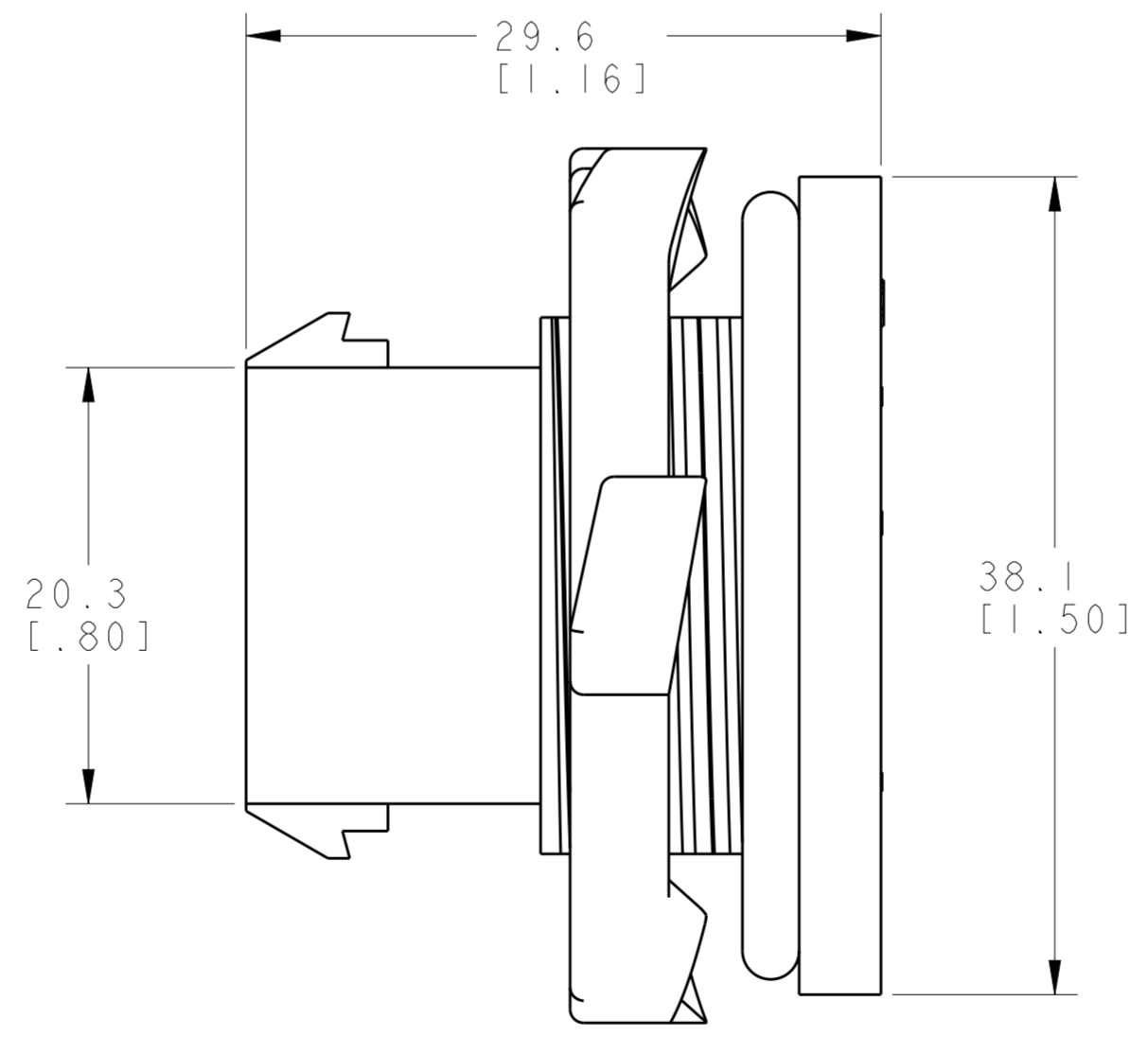
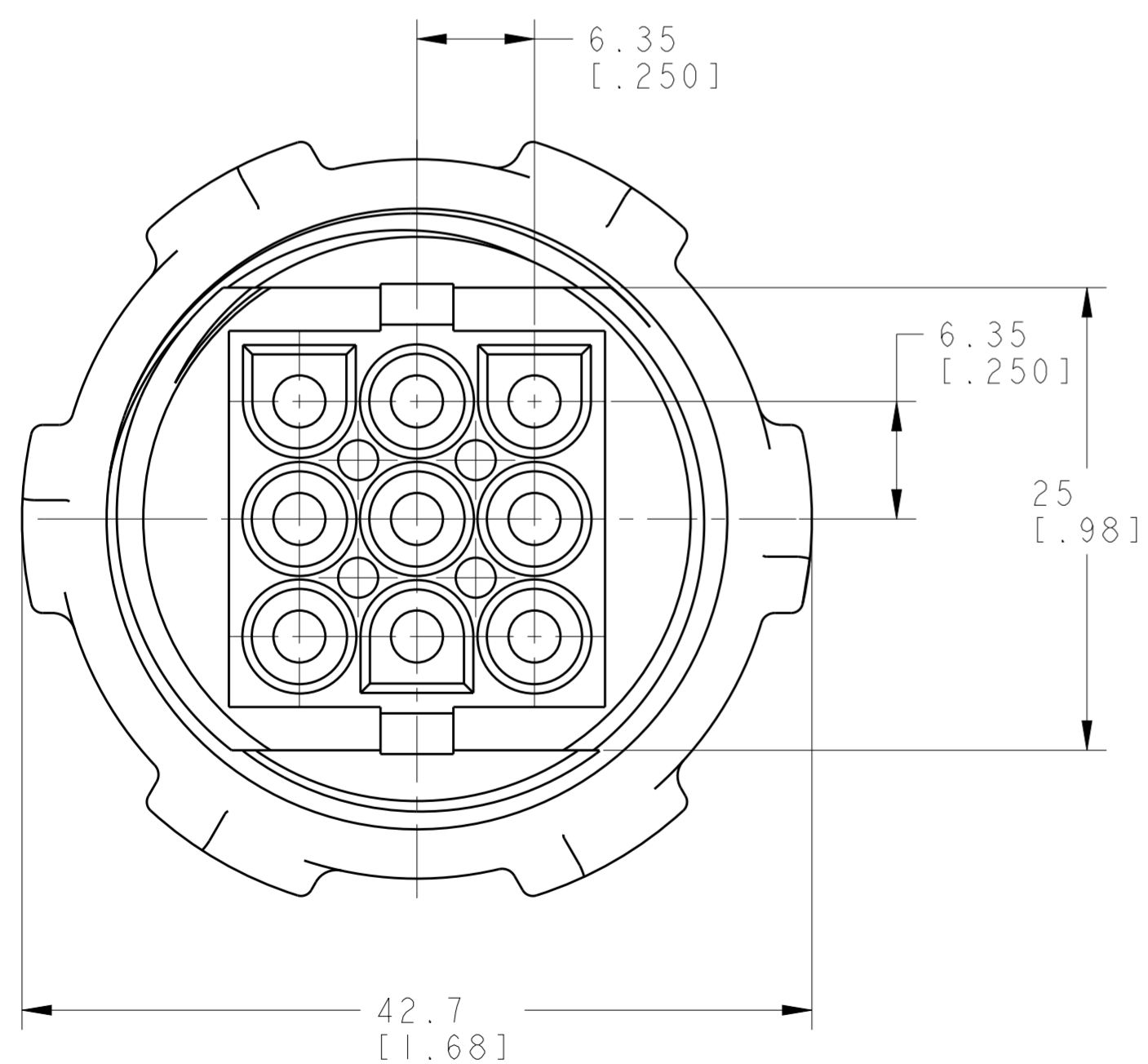

- ① LOCKNUT; METAL
 HOUSING; NYLON, FLAME RETARDANT,
 UL94-V0
 O-RING; NEOPRENE
- ② LOCKNUT; PLATED
- ③ LOCKNUT, SIX (6) OR EIGHT (8) SYMETRICAL
 PLACED GRIP POINTS PERMISSIBLE.
- 4 DIMENSIONS SHOWN REPRESENT PRODUCT IN
 DRY, AS MOLDED, CONDITION. ADDITIONAL
 2% GROWTH DUE TO SUBSEQUENT MOISTURE
 ABSORPTION MAY OCCUR AND SHOULD BE
 ACCOUNTED FOR.

1604254-1
 PART NO

THIS DRAWING IS A CONTROLLED DOCUMENT.		DWN J.C. YOSLER 22APR2002	TE Connectivity	
DIMENSIONS: mm [INCHES]		CHK J.H. WEAVER 22APR2002		
TOLERANCES UNLESS OTHERWISE SPECIFIED:		APVD J.H. WEAVER 22APR2002	NAME BULKHEAD CONNECTOR ASSEMBLY, 9 CIRCUIT, UNIVERSAL MATE-N-LOK (TM)	
0 PLC ±	1 PLC ±0.5 [0.02]	PRODUCT SPEC	SIZE	RESTRICTED TO
2 PLC ±0.13 [0.005]	3 PLC ±	APPLICATION SPEC	CAGE CODE	
4 PLC ±	ANGLES ±	WEIGHT	DRAWING NO	
MATERIAL ①	FINISH ②	CUSTOMER DRAWING	A200779	
SCALE 3:1			SHEET	REV A1