

- 1 POST TO WITHSTAND 13 NEWTONS (3LBS.) MINIMUM AXIAL FORCE IN BOTH DIRECTIONS SHOWN WITHOUT DISLODGING.
- 2 TOLERANCES APPLY TO SOLDER SIDE OF BOARD.
- 3 MEASURED AT SURFACE  $\overline{A}$
- 4 PLASTIC FLASH PERMITTED IN THIS AREA.
- 5 PARTS COMPLY WITH AMP SOLDERABILITY SPEC. NO. 109-11-2.
- 6 ONE HOLE MAY BE UNDERSIZED 1.65-1.52 [.065-.060] DIA. FOR ASSEMBLY RETENTION DURING WAVE SOLDERING.
- 7 MATERIAL: HEADER-THERMOPLASTIC POLYESTER  
GLASS-FILLED 94V-0 (NATURAL)  
POST-COPPER ALLOY (SEE NOTES 13 & 14 FOR PLATING)
- 8 COORDINATE DIMENSION APPLIES FROM CENTER OF ACTUAL FEATURE.
- 9 PLASTIC BURRS CAUSED BY CUT-OFF TOOLING ARE PERMITTED WITHIN THE MAXIMUM TOLERANCE ENVELOPE.
- 10 POST TO BE MEASURED WHEN STRIP IS HELD FLAT.
- 11 POST MUST WITHSTAND TWO 90° BENDS AGAINST EXTRUSION WITHOUT BREAKING.
- 12 DIMENSION SHOULD BE 8.25-10.16 [.325-.400] WHEN MATING WITH A MTA 156 CONNECTOR ASSEMBLY OR 8.25-10.16 [.325-.345] WHEN MATING WITH A SL-156 CONNECTOR ASSEMBLY.
- 13 PLATING: GOLD PLATE AREA, 0.00076 [.000030] GOLD OR 0.00008 [.000003] MIN GOLD FLASH OVER 0.00068 [.000027] PALLADIUM NICKEL, PER TE CONNECTIVITY'S DISCRETION, ALL SIDES, OVER NICKEL UNDERPLATE, 0.00127 [.000050] MIN, ALL SIDES AND ENTIRE LENGTH OF POST.
- 14 BRIGHT TIN/LEAD (93/7) PLATE AREA, 0.00381-0.0089 [.000150-.000350] THICK, ALL FOUR SIDES, 3.18 [.125] MINIMUM.
- 15 MATTE TIN PLATE AREA, [0.00381-0.0089] [.000150-.000350] THICK, ALL FOUR SIDES, 3.18 [.125] MINIMUM.
- 16 OBSOLETE PARTS: OBSOLETE CIS STREAMLINING PER D.RENAUD/D.SINISI

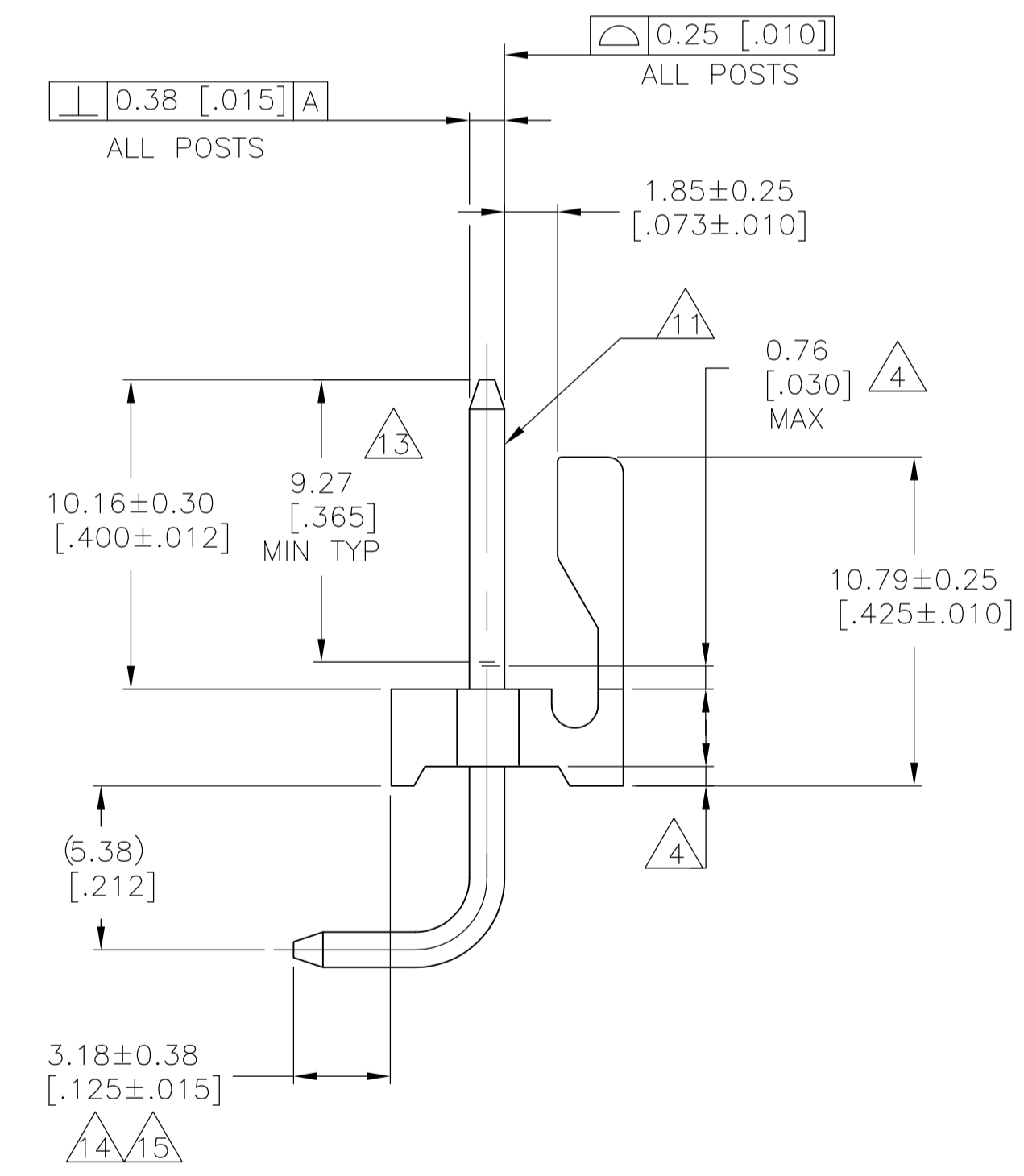
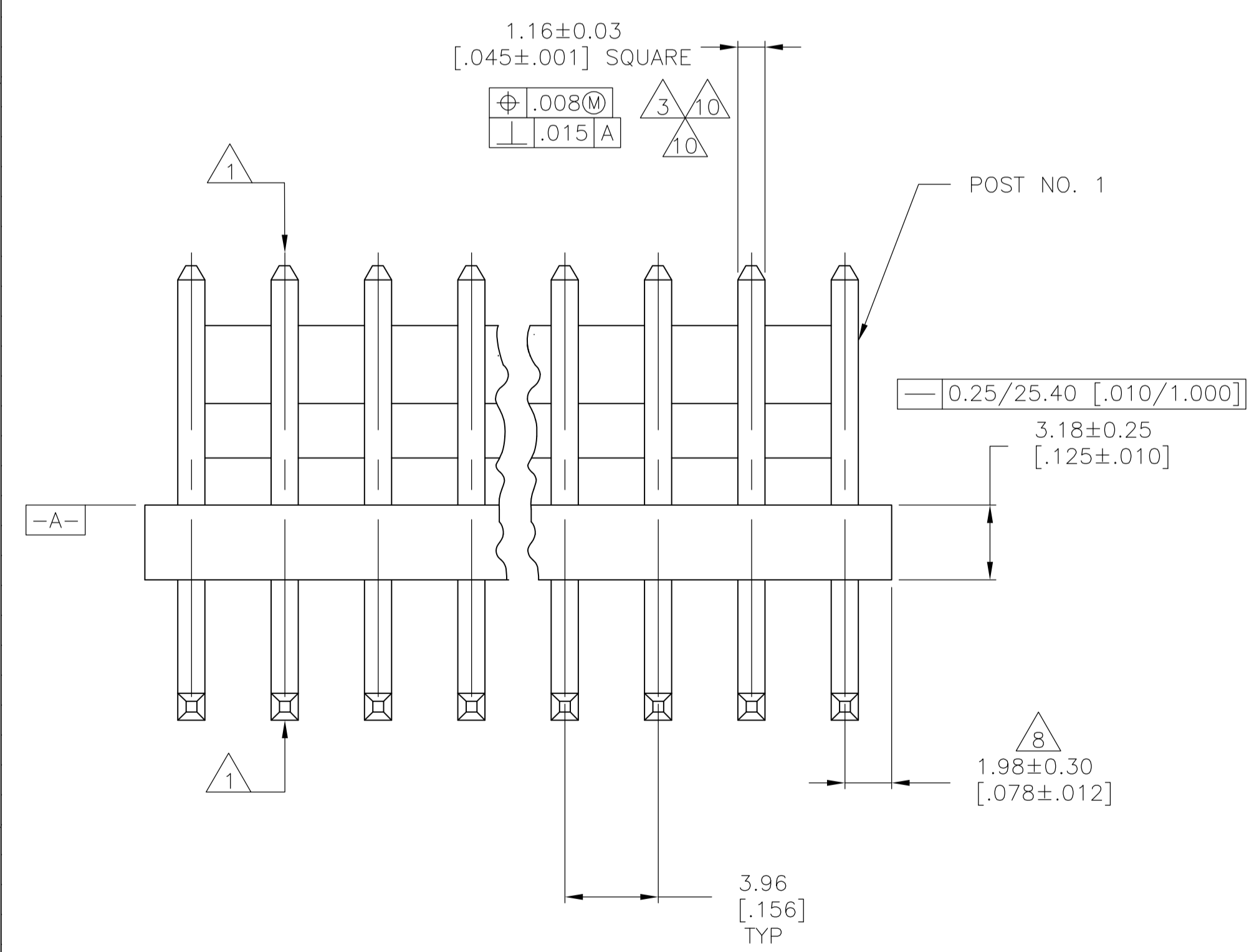
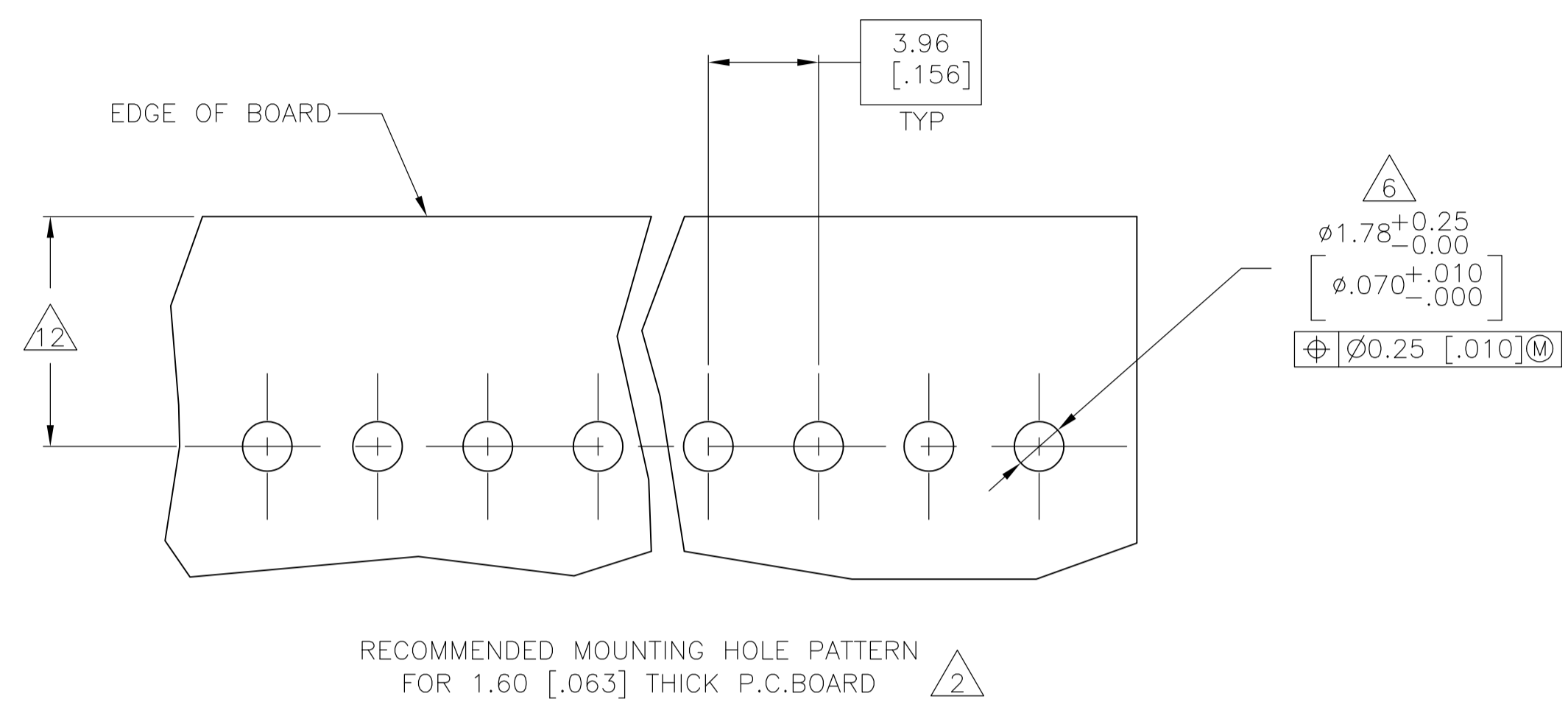
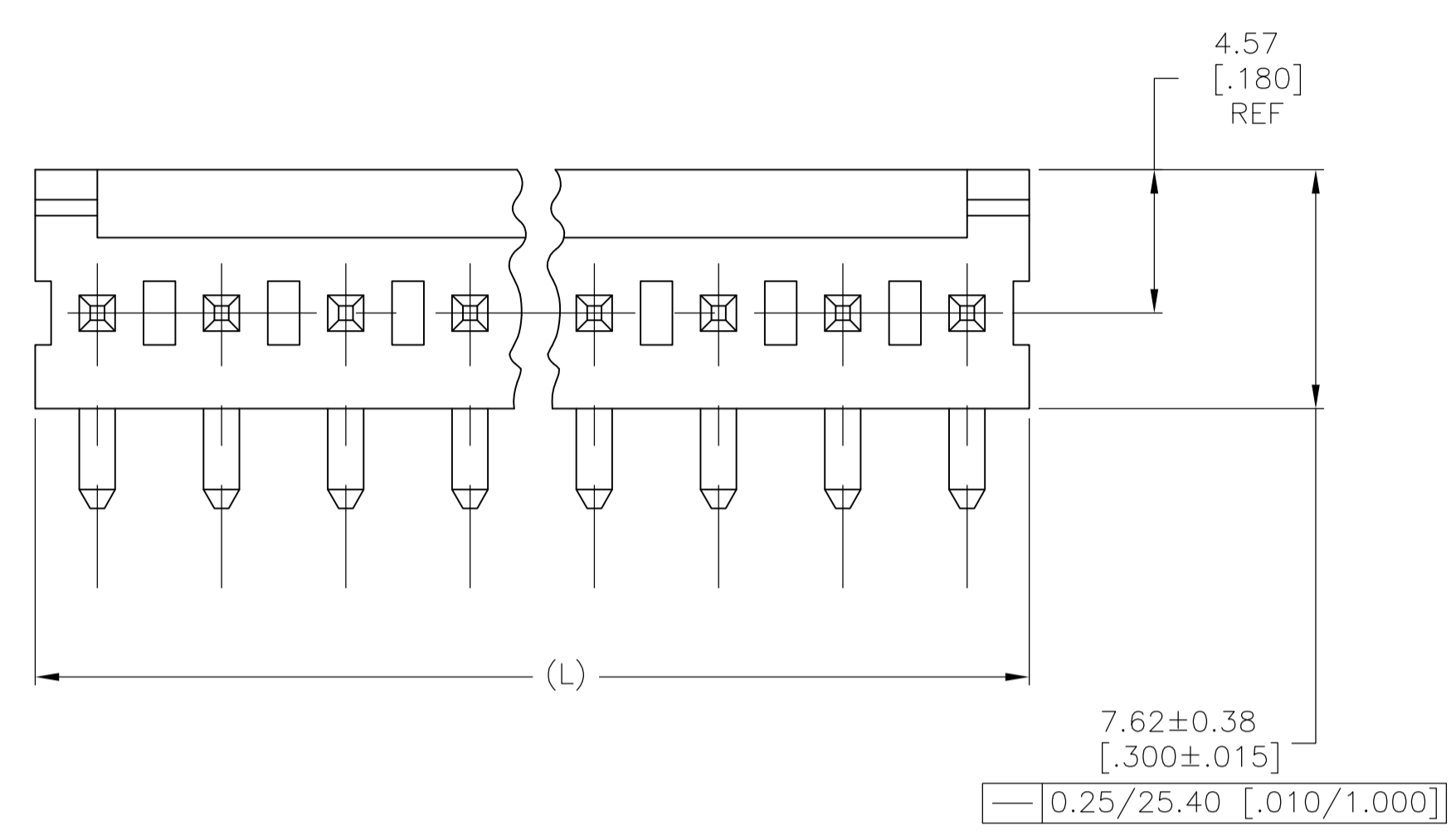

LEAD FREE	13/15	95.10	3.744	24	5-641210-4
	13/15	91.14	3.588	23	5-641210-3
	13/15	87.17	3.432	22	5-641210-2
	13/15	83.21	3.276	21	5-641210-1
	13/15	79.25	3.120	20	5-641210-0
	13/15	75.29	2.964	19	4-641210-9
	13/15	71.32	2.808	18	4-641210-8
	13/15	67.36	2.652	17	4-641210-7
	13/15	63.40	2.496	16	4-641210-6
	13/15	59.44	2.340	15	4-641210-5
	13/15	55.47	2.184	14	4-641210-4
	13/15	51.51	2.028	13	4-641210-3
	13/15	47.55	1.872	12	4-641210-2
	13/15	43.59	1.716	11	4-641210-1
	13/15	39.62	1.560	10	4-641210-0
	13/15	35.66	1.404	9	3-641210-9
	13/15	31.70	1.248	8	3-641210-8
	13/15	27.74	1.092	7	3-641210-7
	13/15	23.77	.936	6	3-641210-6
	13/15	19.81	.780	5	3-641210-5
	13/15	15.85	.624	4	3-641210-4
	13/15	11.89	.468	3	3-641210-3
13/15	7.92	.312	2	3-641210-2	
FINISH	MM	[IN]	NO. OF POSN	PART NUMBER	

LEAD	13/14	95.10	3.744	24	2-641210-4
	13/14	91.14	3.588	23	2-641210-3
	13/14	87.17	3.432	22	2-641210-2
	13/14	83.21	3.276	21	2-641210-1
	13/14	79.25	3.120	20	2-641210-0
	13/14	75.29	2.964	19	1-641210-9
	13/14	71.32	2.808	18	1-641210-8
	13/14	67.36	2.652	17	1-641210-7
	13/14	63.40	2.496	16	1-641210-6
	13/14	59.44	2.340	15	1-641210-5
	13/14	55.47	2.184	14	1-641210-4
	13/14	51.51	2.028	13	1-641210-3
	13/14	47.55	1.872	12	1-641210-2
	13/14	43.59	1.716	11	1-641210-1
	13/14	39.62	1.560	10	1-641210-0
	13/14	35.66	1.404	9	641210-9
	13/14	31.70	1.248	8	641210-8
	13/14	27.74	1.092	7	641210-7
	13/14	23.77	.936	6	641210-6
	13/14	19.81	.780	5	641210-5
	13/14	15.85	.624	4	641210-4
	13/14	11.89	.468	3	641210-3
13/14	7.92	.312	2	641210-2	
FINISH	MM	[IN]	NO. OF POSN	PART NUMBER	

METRIC

THIS DRAWING IS A CONTROLLED DOCUMENT.

DIMENSIONS: mm [INCHES]	TOLERANCES UNLESS OTHERWISE SPECIFIED:	DIN S. HOOVER 07NOV02	TE Connectivity
0 PLC ± -	1 PLC ± -	APVD D. ROSSI 07NOV02	NAME
2 PLC ± -	3 PLC ± .005	APVD D. ROSSI 07NOV02	PRODUCT SPEC
4 PLC ± -	ANGLES ± -	APPLICATION SPEC	SIZE CAGE CODE DRAWING NO
MATERIAL	FINISH	WEIGHT	A1 00779C=641210
		CUSTOMER DRAWING	SCALE 5:1 SHEET 1 OF 1 REV AE

# Mouser Electronics

Authorized Distributor

Click to View Pricing, Inventory, Delivery & Lifecycle Information:

[TE Connectivity:](#)

[3-641210-6](#)