

THIS DOCUMENT IS THE PROPERTY OF KEYSTONE ELECTRONICS CORP. AND SHALL NOT BE REPRODUCED, DISTRIBUTED OR USED AS A BASIS FOR MANUFACTURE WITHOUT PRIOR WRITTEN PERMISSION FROM KEYSTONE ELECTRONICS CORP.

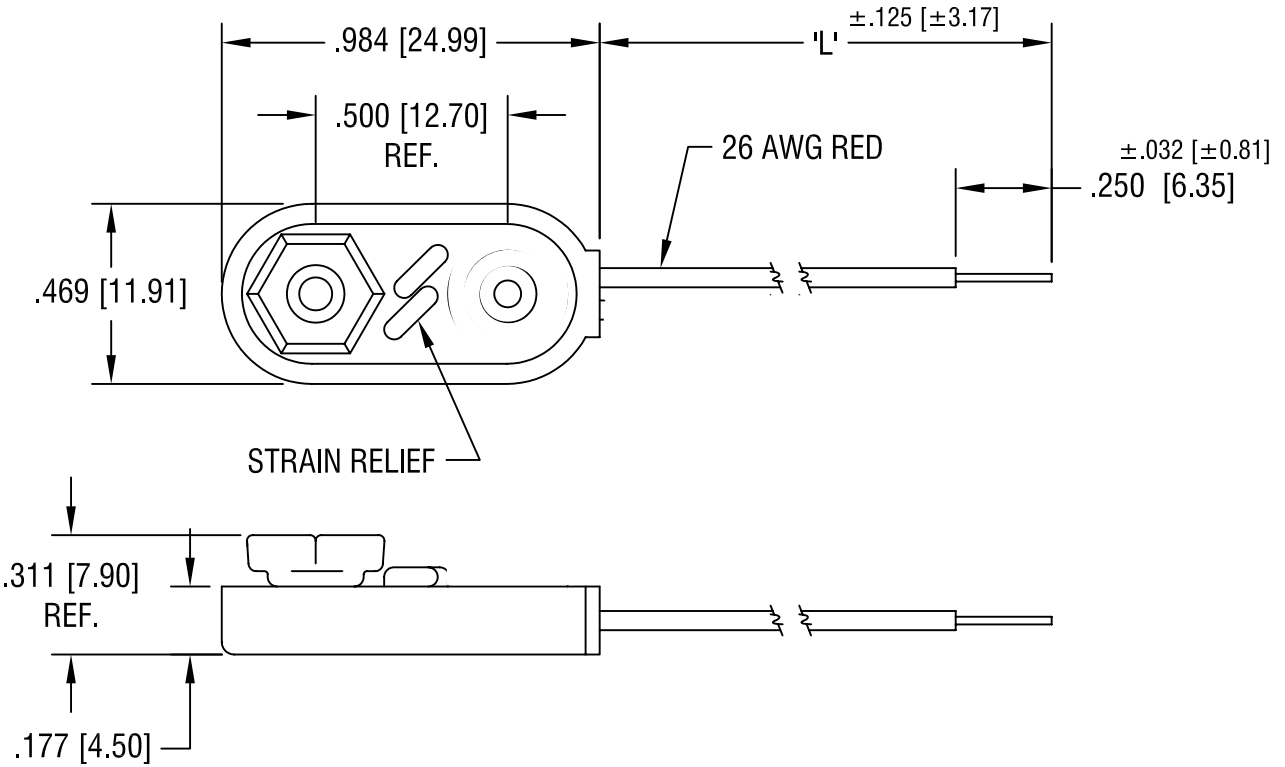

NOTE:

- 1. MAT'L:
 WIRE: 26 AWG, 1007 UL/CSA APPROVED
 CONTACTS: BRASS, NICKEL PLATE
 COVER: MOLDED ABS
- 2. RED WIRE CONNECTED TO FEMALE CONTACT;
~~BLACK WIRE CONNECTED TO MALE CONTACT.~~

PART NO.	'L' DIM.
232-M	4.000 [101.60]
233-M	6.000 [152.40]
234-M	8.000 [203.20]

KEYSTONE ELECTRONICS CORP.

ASTORIA, N.Y. 11105-2017

PART NAME MOLDED ECONOMY '9' VOLT BATTERY STRAP			
MATERIAL AS NOTED			
FINISH AS NOTED		DRN BY BOONE	DATE 11.11.05
		APP'D LN	SCALE 2X
TOLERANCES DECIMAL ANGULAR	INCH [MM] ±.020 [±0.50] ± 1°	CODE C/M	DWG NO. 9-234-M-SNAP
UNLESS OTHERWISE SPECIFIED			

DATE	DESCRIPTION	REV.

Mouser Electronics

Authorized Distributor

Click to View Pricing, Inventory, Delivery & Lifecycle Information:

[Keystone Electronics:](#)

[233-M](#)