

THIS DRAWING IS UNPUBLISHED. RELEASED FOR PUBLICATION
 © COPYRIGHT BY TYCO ELECTRONICS CORPORATION. ALL RIGHTS RESERVED.

LOC		DIST		REVISIONS			
P	LTR	DESCRIPTION		DATE	DWN	APVD	
	A	EC-05-5819		29AUG06	MB	MS	
	A1	REVISED PER ECO-10-000444		19JAN10	KK	HMR	

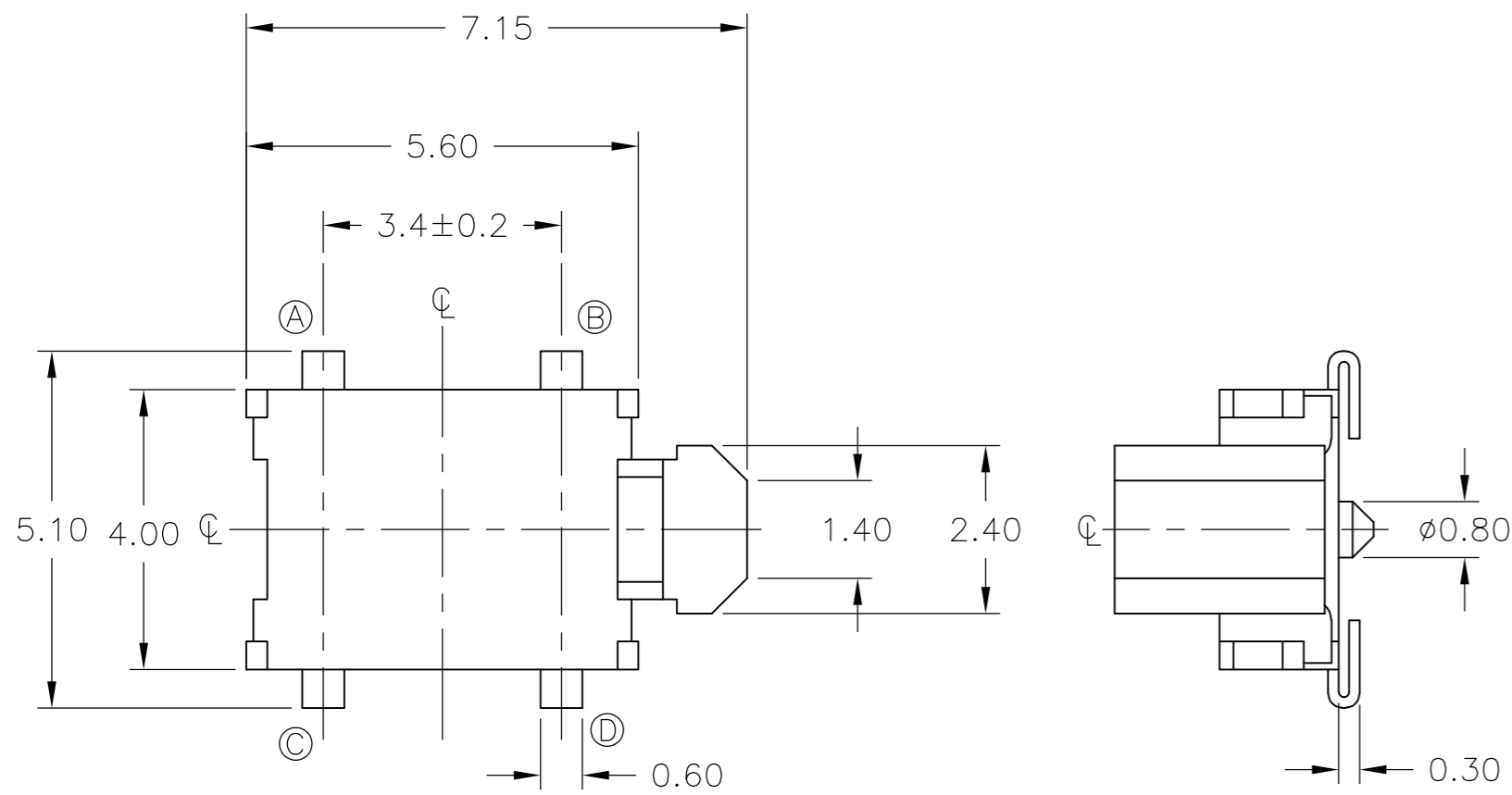

SCHMATIC

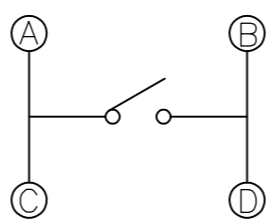

PIERCING PLAN

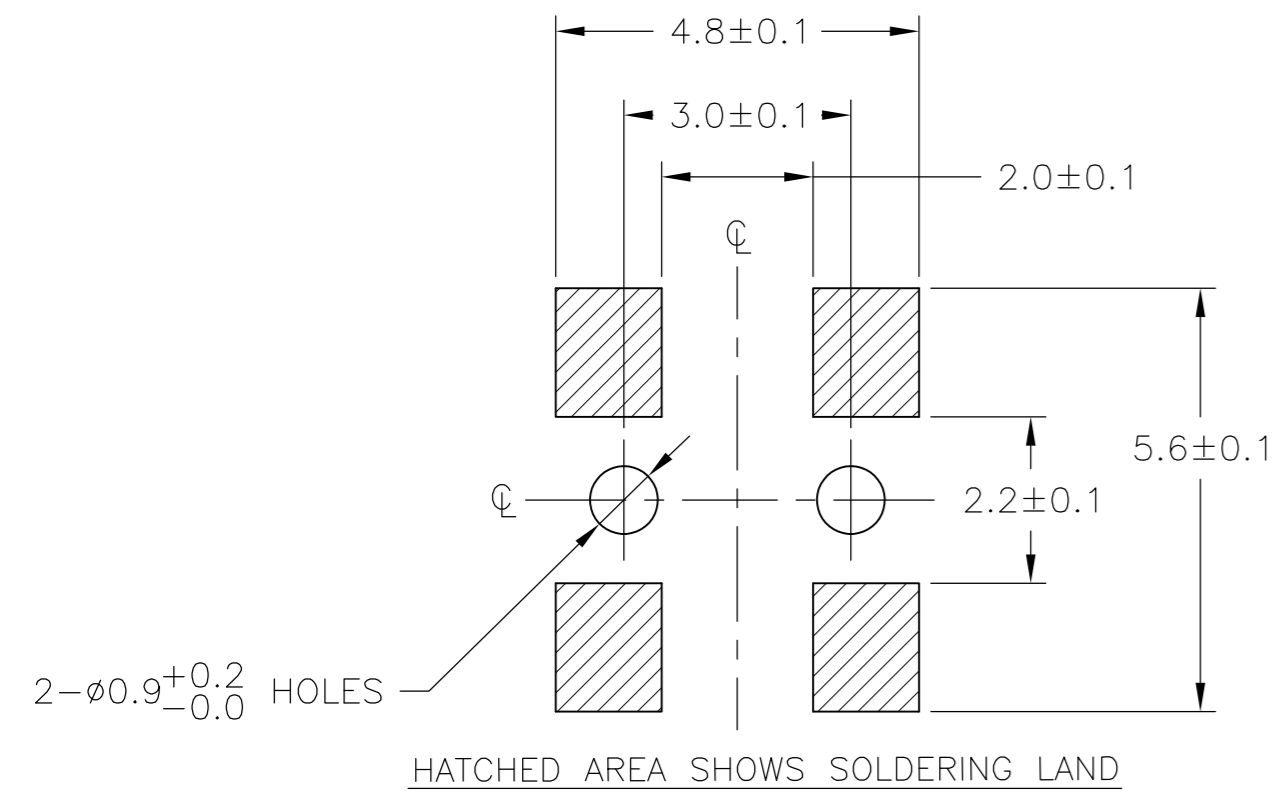
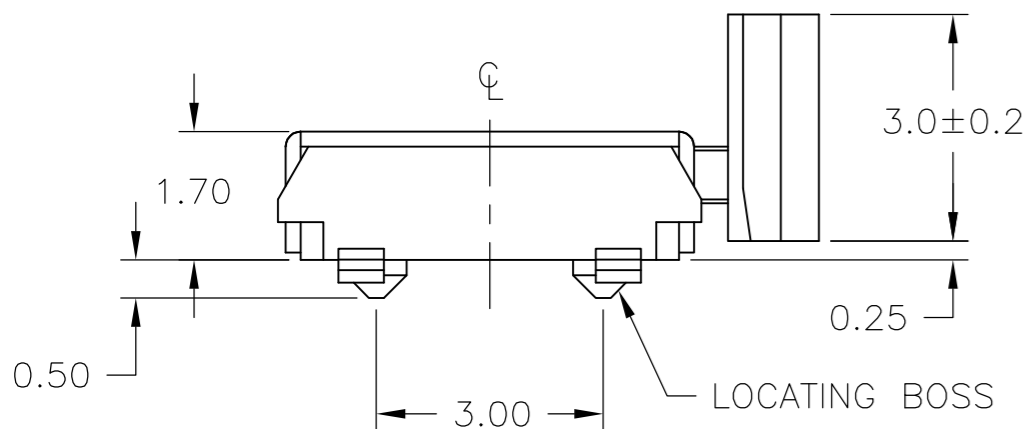
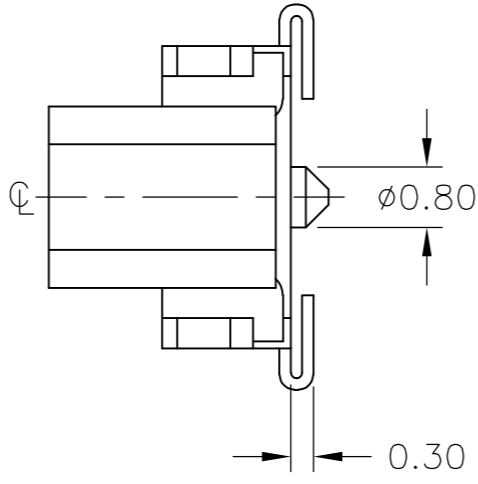

MATERIALS:

CASE: NYLON 4/6, UL94V-0, BLACK
 ACTUATOR: NYLON 4/6, UL94V-0, BLACK
 COVER: STAINLESS STEEL
 CONTACT PLATE: STAINLESS STEEL, SILVER CLAD OVER NICKEL PLATE
 TERMINALS: COPPER ALLOY, SILVER OVER NICKEL PLATE
 MASKING TAPE: TEFLON

ELECTRICAL:

CONTACT RATING: 50mA @ 12VDC, PER EIA-448, METHOD 6
 INITIAL CONTACT RESISTANCE: 100 MILLIOHMS MAX
 PER EIA-364-23B, EACH POSN.
 INSULATION RESISTANCE: 100 MEGAOHMS MIN.
 PER EIA-364-21C EACH POSN.
 DIELECTRIC STRENGTH: 250 VAC FOR 1 MINUTE,
 PER EIA-364-20B, CONDITION 1 EACH POSN
 CONTACT BOUNCE: 10 MILLISECONDS MAX
 LIFE EXPECTANCY: UP TO 100,000 CYCLES
 FINAL CONTACT RESISTANCE: 200 MILLIOHMS MAX
 FINAL ACTUATING FORCE: ±30% OF INITIAL VALUE
 FINAL CONTACT BOUNCE: 20 MILLISECONDS MAX

MECHANICAL:

ACTUATION FORCE: 160 ±70/40 GF
 ACTUATION TRAVEL: 0.30 ±0.1/-0.2 MM
 LIFE EXPECTANCY: 100,000 CYCLES MIN(2 CYCLES PER SECOND
 AND 150% ACTUATION FORCE) PER EIA-448 METHODS 8 AND 9
 VIBRATION: PER EIA 364-28D, CONDITION VII, LEVEL E
 MECHANICAL SHOCK: PER EIA-364-27C, CONDITION A

ENVIROMENTAL:

OPERATING TEMPERATURE: -20° TO +70°C, PER EIA-448, METHOD 10
 STORAGE TEMPERATURE: -30° TO +80°C
 HUMIDITY AND TEMPERATURE CYCLING: PER EIA-364-31B, METHOD III
 THERMAL SHOCK: PER EIA-364-32C, -30° TO +80°C
 SOLDERABILITY: PER EIA-364-52, CLASS 2, CATEGORY 1,
 TEMP: 245°C MAX, TIME: 2.5 SECONDS MAX, 95% MINIMUM COVERAGE
 RESISTANCE TO SOLDER HEAT, PER EIA-364-56A,
 PROCEDURE 4 AND 5, LEVEL 3

PACKAGING: TAPE AND REEL PACKAING PER EIA 481

1 OBSOLETE PARTS: OBSOLETE CIS STREAMLINING PER D.RENAUD/D.SINISI

	QTY/REEL	PITCH	WIDTH	PACKAGING	FEATURES	PART NUMBER
	2000	8MM	16MM	TAPE AND REEL	W/BOSS	1825106-4
	-	-	-	BULK	W/BOSS	1825106-3
OBSOLETE	2000	8MM	16MM	TAPE AND REEL	W/O BOSS	1825106-2
	-	-	-	BULK	W/O BOSS	1825106-1

THIS DRAWING IS A CONTROLLED DOCUMENT.		DWN R BROWN 15DEC04	Tyco Electronics Corporation Harrisburg, PA 17105	
DIMENSIONS: MM		CHK M SARVER 15DEC04	NAME TACTILE SWITCH, SIDE ACTUATED, SMT	
TOLERANCES UNLESS OTHERWISE SPECIFIED:		APVD M SARVER 15DEC04	PRODUCT SPEC	
0 PLC ± -		APPLICATION SPEC		
1 PLC ± 0.3		WEIGHT		
2 PLC ± -		SCALE A2 00779 C=1825106		
3 PLC ± -		SHEET 1 OF 1		
4 PLC ± -		REV A1		
ANGLES ± -		CUSTOMER DRAWING		
FINISH		SCALE 10:1		

Mouser Electronics

Authorized Distributor

Click to View Pricing, Inventory, Delivery & Lifecycle Information:

[TE Connectivity:](#)

[1825106-4](#)