

### General Description

The MIC2171 is a complete 100kHz SMPS current-mode controller with an internal 65V 2.5A power switch.

Although primarily intended for voltage step-up applications, the floating switch architecture of the MIC2171 makes it practical for step-down, inverting, and Cuk configurations as well as isolated topologies.

Operating from 3V to 40V, the MIC2171 draws only 7mA of quiescent current, making it attractive for battery operated supplies.

The MIC2171 is available in a 5-pin TO-220 or TO-263 for  $-40^{\circ}\text{C}$  to  $+85^{\circ}\text{C}$  operation.

Data sheets and support documentation can be found on Micrel's web site at: [www.micrel.com](http://www.micrel.com).

### Features

- 2.5A, 65V internal switch rating
- 3V to 40V input voltage range
- Current-mode operation, 2.5A peak
- Internal cycle-by-cycle current limit
- Thermal shutdown
- Twice the frequency of the LM2577
- Low external parts count
- Operates in most switching topologies
- 7mA quiescent current (operating)
- Fits LT1171/LM2577 TO-220 and TO-263 sockets

### Applications

- Laptop/palmtop computers
- Battery operated equipment
- Hand-held instruments
- Off-line converter up to 50W (requires external power switch)
- Pre-driver for higher power capability

### Typical Application

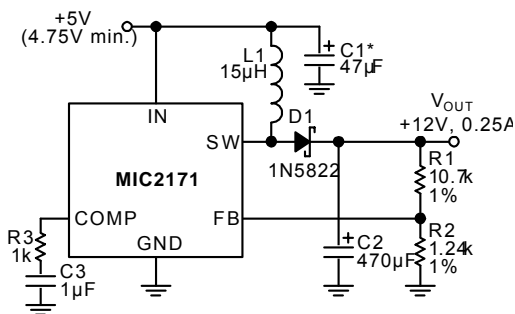

\* Locate near MIC2171 when supply leads > 2"

Figure 1. MIC2171 5V to 12V Boost Converter

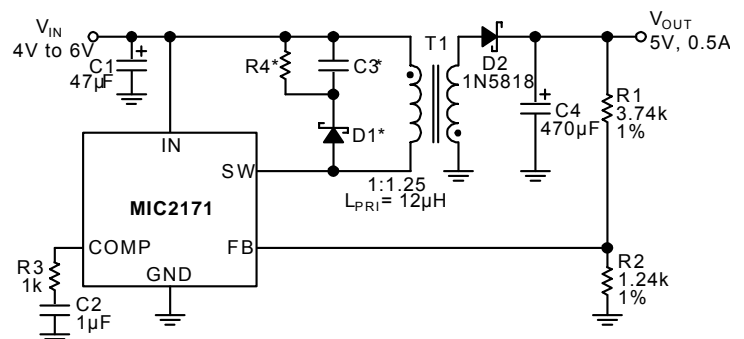

\* Optional voltage clipper (may be req'd if T1 leakage inductance too high)

Figure 2. MIC2171 5V Flyback Converter

## Ordering Information

Part Number		Temperature Range	Package
Standard	RoHS Compliant*		
MIC2171BT	MIC2171WT	-40° to +85°C	5-Pin TO-220
MIC2171BU	MIC2171WU	-40° to +85°C	5-Pin TO-263

\*RoHS compliant with "high-melting solder" exemption.

## Pin Configuration

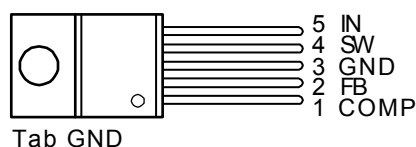

5-Pin TO-220 (T)

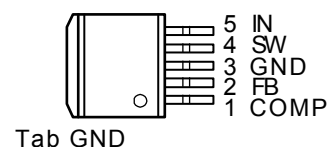

5-Pin TO-263 (U)

## Pin Description

Pin Number	Pin Name	Pin Function
1	COMP	Frequency Compensation: Output of transconductance-type error amplifier. Primary function is for loop stabilization. Can also be used for output voltage soft-start and current limit tailoring.
2	FB	Feedback: Inverting input of error amplifier. Connect to external resistive divider to set power supply output voltage.
3	GND	Ground: Connect directly to the input filter capacitor for proper operation (see applications info).
4	SW	Power Switch Collector: Collector of NPN switch. Connect to external inductor or input voltage depending on circuit topology.
5	IN	Supply Voltage: 3.0V to 40V

## Absolute Maximum Ratings

Supply Voltage ( $V_{IN}$ ).....	40V
Switch Voltage ( $V_{SW}$ ).....	65V
Feedback Voltage (transient, 1ms) ( $V_{FB}$ ) .....	$\pm 15V$
Lead Temperature (soldering, 10 sec.).....	300°C
Storage Temperature ( $T_s$ ) .....	-65°C to +150°C
ESD Rating <sup>(1)</sup>	

## Operating Ratings

Operating Temperature Range .....	-40°C to +85°C
Junction Temperature ( $T_J$ ) .....	-55°C to +150°C
Thermal Resistance	
TO-220-5 ( $\theta_{JA}$ ) <sup>(2)</sup> .....	45°C/W
TO-263-5 ( $\theta_{JA}$ ) <sup>(3)</sup> .....	45°C/W

## Electrical Characteristics

$V_{IN} = 5V$ ;  $T_A = 25^\circ C$ , **bold** values indicate  $-40^\circ C \leq T_A \leq +85^\circ C$ , unless noted.

Parameter	Condition	Min	Typ	Max	Units
<b>Reference Section</b>					
Feedback Voltage ( $V_{FB}$ )	$V_{COMP} = 1.24V$	1.220 <b>1.214</b>	1.240	1.264 <b>1.274</b>	V V
Feedback Voltage Line Regulation	$3V \leq V_{IN} \leq 40V$ $V_{COMP} = 1.24V$		<b>0.6</b>		%/V
Feedback Bias Current ( $I_{FB}$ )	$V_{FB} = 1.24V$		310	750 <b>1100</b>	nA nA
<b>Error Amplifier Section</b>					
Transconductance ( $g_m$ )	$\Delta I_{COMP} = \pm 25\mu A$	3.0 <b>2.4</b>	3.9	6.0 <b>7.0</b>	$\mu A/mV$ $\mu A/mV$
Voltage Gain ( $A_V$ )	$0.9V \leq V_{COMP} \leq 1.4V$	400	800	2000	V/V
Output Current	$V_{COMP} = 1.5V$	125 <b>100</b>	175	350 <b>400</b>	$\mu A$ $\mu A$
Output Swing	High Clamp, $V_{FB} = 1V$ Low Clamp, $V_{FB} = 1.5V$	1.8 0.25	2.1 0.35	2.3 0.52	V V
Compensation Pin Threshold	Duty Cycle = 0	0.8 <b>0.6</b>	0.9	1.08 <b>1.25</b>	V V
<b>Output Switch Section</b>					
ON Resistance	$I_{SW} = 2A$ , $V_{FB} = 0.8V$		0.37	0.50 <b>0.55</b>	$\Omega$ $\Omega$
Current Limit	Duty Cycle = 50%, $T_J \geq 25^\circ C$ Duty Cycle = 50%, $T_J < 25^\circ C$ Duty Cycle = 80%, <b>Note 4</b>	<b>2.5</b> <b>2.5</b> <b>2.5</b>	<b>3.6</b> <b>4.0</b> <b>3.0</b>	<b>5.0</b> <b>5.5</b> <b>5.0</b>	A A A
Breakdown Voltage (BV)	$3V \leq V_{IN} \leq 40V$ $I_{SW} = 5mA$	<b>65</b>	75		V
<b>Oscillator Section</b>					
Frequency ( $f_O$ )		88 <b>85</b>	100	112 <b>115</b>	kHz kHz
Duty Cycle [ $\delta(\max)$ ]		80	90	95	%
<b>Input Supply Voltage Section</b>					
Minimum Operating Voltage			2.7	<b>3.0</b>	V
Quiescent Current ( $I_Q$ )	$3V \leq V_{IN} \leq 40V$ , $V_{COMP} = 0.6V$ , $I_{SW} = 0$		7	9	mA
Supply Current Increase ( $\Delta I_{IN}$ )	$\Delta I_{SW} = 2A$ , $V_{COMP} = 1.5V$ , during switch on-time		9	20	mA

### Notes:

1. Devices are ESD sensitive. Handling precautions recommended.
2. Mounted vertically, no external heat sink, 1/4 inch leads soldered to PC board containing approximately 4 inch squared copper area surrounding leads.
3. All ground leads soldered to approximately 2 inches squared of horizontal PC board copper area.
4. For duty cycles ( $\delta$ ) between 50% and 95%, minimum guaranteed switch current is  $I_{CL} = 1.66(2-\delta)$  Amp (Pk).

# Typical Characteristics

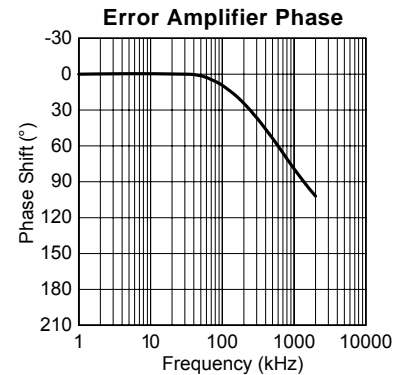
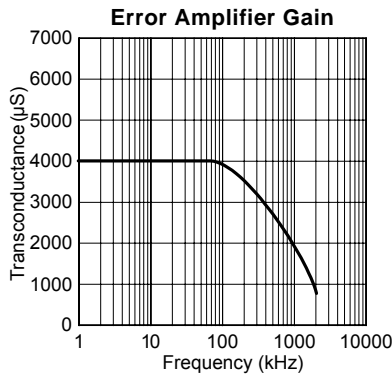
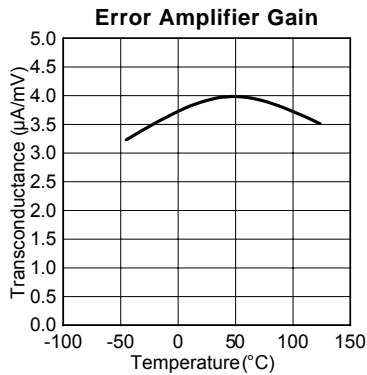
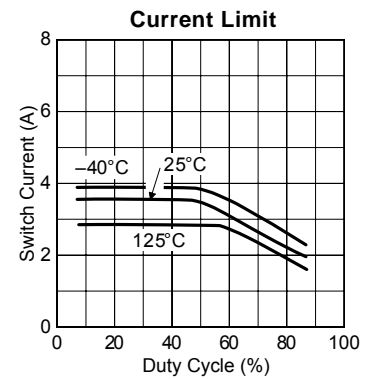
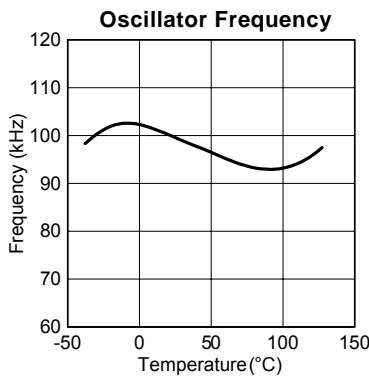
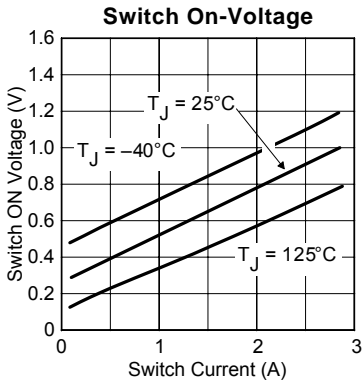
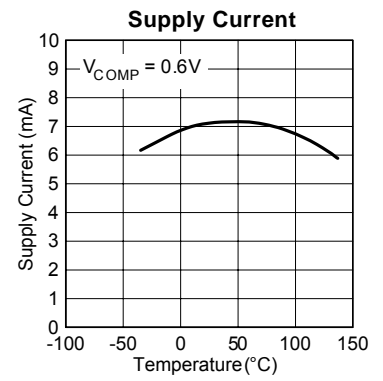
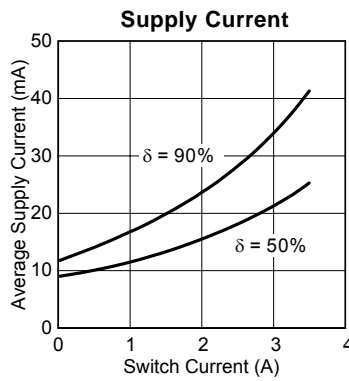
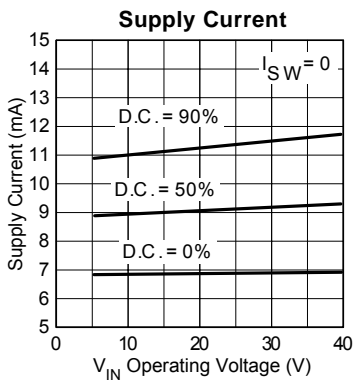
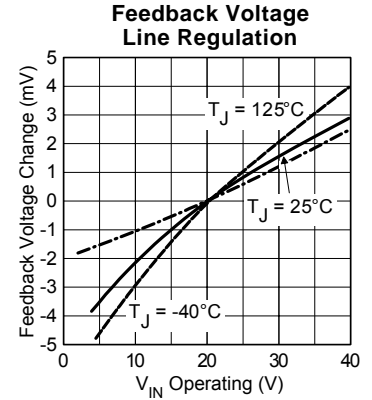
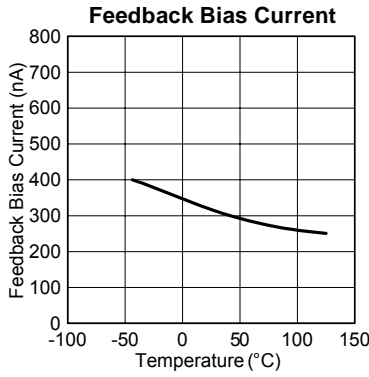
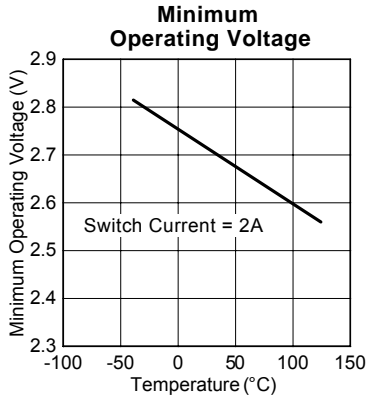

## Functional Diagram

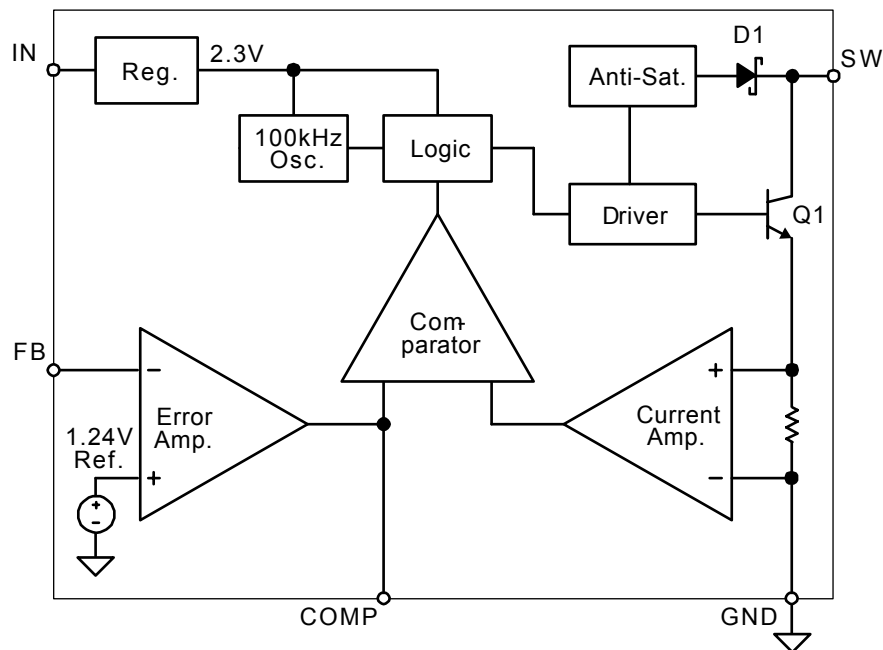

## Functional Description

Refer to "Block Diagram MIC2171".

### Internal Power

The MIC2171 operates when  $V_{IN}$  is  $\geq 2.6V$ . An internal 2.3V regulator supplies biasing to all internal circuitry including a precision 1.24V band gap reference.

### PWM Operation

The 100kHz oscillator generates a signal with a duty cycle of approximately 90%. The current-mode comparator output is used to reduce the duty cycle when the current amplifier output voltage exceeds the error amplifier output voltage. The resulting PWM signal controls a driver which supplies base current to output transistor Q1.

### Current-Mode Advantages

The MIC2171 operates in current mode rather than voltage mode. There are three distinct advantages to this technique. Feedback loop compensation is greatly simplified because inductor current sensing removes a pole from the closed loop response. Inherent cycle-by-cycle current limiting greatly improves the power switch

reliability and provides automatic output current limiting. Finally, current-mode operation provides automatic input voltage feed forward which prevents instantaneous input voltage changes from disturbing the output voltage setting.

### Anti-Saturation

The anti-saturation diode (D1) increases the usable duty cycle range of the MIC2171 by eliminating the base to collector stored charge which would delay Q1's turnoff.

### Compensation

Loop stability compensation of the MIC2171 can be accomplished by connecting an appropriate network from either COMP to circuit ground (see "Typical Applications") or COMP to FB.

The error amplifier output (COMP) is also useful for soft start and current limiting. Because the error amplifier output is a transconductance type, the output impedance is relatively high which means the output voltage can be easily clamped or adjusted externally.

## Application Information

### Soft Start

A diode-coupled capacitor from COMP to circuit ground slows the output voltage rise at turn on (Figure 3).

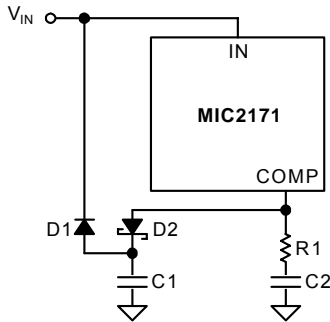

Figure 3. Soft Start

The additional time it takes for the error amplifier to charge the capacitor corresponds to the time it takes the output to reach regulation. Diode D1 discharges C1 when  $V_{IN}$  is removed.

### Current Limit

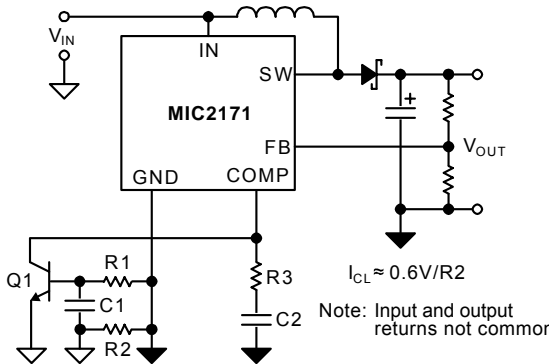

Figure 4. Current Limit

The maximum current limit of the MIC2171 can be reduced by adding a voltage clamp to the COMP output (Figure 4). This feature can be useful in applications requiring either a complete shutdown of Q1's switching action or a form of current fold-back limiting. This use of the COMP output does not disable the oscillator, amplifiers or other circuitry, therefore, the supply current is never less than approximately 5mA.

### Thermal Management

Although the MIC2171 family contains thermal protection circuitry, for best reliability, avoid prolonged operation with junction temperatures near the rated maximum.

The junction temperature is determined by first calculating the power dissipation of the device. For the MIC2171, the total power dissipation is the sum of the device operating losses and power switch losses.

The device operating losses are the dc losses associated with biasing all of the internal functions plus

the losses of the power switch driver circuitry. The dc losses are calculated from the supply voltage ( $V_{IN}$ ) and device supply current ( $I_Q$ ). The MIC2171 supply current is almost constant regardless of the supply voltage (see "Electrical Characteristics"). The driver section losses (not including the switch) are a function of supply voltage, power switch current, and duty cycle.

$$P_{(bias+driver)} = (V_{IN} I_Q) + (V_{IN(min)} \times I_{SW} \times \Delta I_{IN})$$

where:

$P_{(bias+driver)}$  = device operating losses

$V_{IN(min)}$  = supply voltage =  $V_{IN} - V_{SW}$

$I_Q$  = typical quiescent supply current

$I_{CL}$  = power switch current limit

$\Delta I_{IN}$  = typical supply current increase

As a practical example refer to Figure 1.

$$V_{IN} = 5.0V$$

$$I_Q = 0.007A$$

$$I_{CL} = 2.21A$$

$$\delta = 66.2\% (0.662)$$

then:

$$V_{IN(min)} = 5.0V - (2.21 \times 0.37) = 4.18V$$

$$P_{(bias+driver)} = (5 \times 0.007) + (4.18 \times 2.21 \times 0.009)$$

$$P_{(bias+driver)} = 0.1W$$

Power switch dissipation calculations are greatly simplified by making two assumptions which are usually fairly accurate. First, the majority of losses in the power switch are due to on-losses. To find these losses, assign a resistance value to the collector/emitter terminals of the device using the saturation voltage versus collector current curves (see Typical Performance Characteristics). Power switch losses are calculated by modeling the switch as a resistor with the switch duty cycle modifying the average power dissipation.

$$P_{SW} = (I_{SW})^2 R_{SW} \delta$$

where:

$\delta$  = duty cycle

$$\delta = \frac{V_{OUT} + V_F - V_{IN(min)}}{V_{OUT} + V_F}$$

$$V_{SW} = I_{CL} (R_{SW})$$

$V_{OUT}$  = output voltage

$V_F$  = D1 forward voltage drop at  $I_{OUT}$

From the Typical performance Characteristics:

$$R_{SW} = 0.37\Omega$$

then:

$$P_{SW} = (2.21)^2 \times 0.37 \times 0.662$$

$$P_{SW} = 1.2W$$

$$P_{(total)} = 1.2 + 0.1$$

$$P_{(total)} = 1.3W$$

The junction temperature for any semiconductor is calculated using the following:

$$T_J = T_A + P_{(total)} \theta_{JA}$$

where:

- $T_J$  = junction temperature
- $T_A$  = ambient temperature (maximum)
- $P_{(total)}$  = total power dissipation
- $\theta_{JA}$  = junction to ambient thermal resistance

For the practical example:

- $T_A = 70^\circ\text{C}$
- $\theta_{JA} = 45^\circ\text{C/W (TO-220)}$

then:

$$T_J = 70 + (1.24 \times 45)$$

$$T_J = 126^\circ\text{C}$$

This junction temperature is below the rated maximum of  $150^\circ\text{C}$ .

### Grounding

Refer to Figure 5. Heavy lines indicate high current paths.

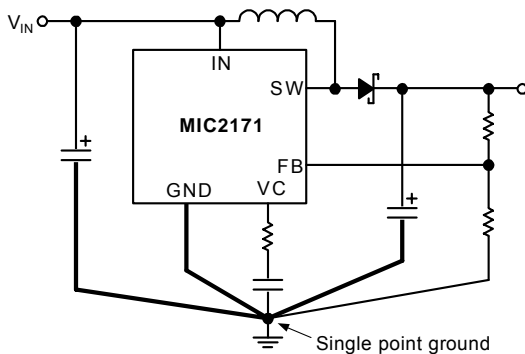

**Figure 5. Single Point Ground**

A single point ground is strongly recommended for proper operation.

The signal ground, compensation network ground, and feed-back network connections are sensitive to minor voltage variations. The input and output capacitor grounds and power ground conductors will exhibit voltage drop when carrying large currents. Keep the sensitive circuit ground traces separate from the power ground traces. Small voltage variations applied to the sensitive circuits can prevent the MIC2171 or any switching regulator from functioning properly.

### Boost Conversion

Refer to Figure 1 for a typical boost conversion application where a +5V logic supply is available but +12V at 0.25A is required.

The first step in designing a boost converter is determining whether inductor L1 will cause the converter to operate in either continuous or discontinuous mode.

Discontinuous mode is preferred because the feedback control of the converter is simpler.

When L1 discharges its current completely during the MIC2171 off-time, it is operating in discontinuous mode.

L1 is operating in continuous mode if it does not discharge completely before the MIC2171 power switch is turned on again.

### Discontinuous Mode Design

Given the maximum output current, solve equation (1) to determine whether the device can operate in discontinuous mode without initiating the internal device current limit.

$$(1) \quad I_{OUT} \leq \frac{\left(\frac{I_{CL}}{2}\right) V_{IN(min)} \delta}{V_{OUT}}$$

$$(1a) \quad \delta = \frac{V_{OUT} + V_F - V_{IN(min)}}{V_{OUT} + V_F}$$

where:

$I_{CL}$  = internal switch current limit

$$I_{CL} = 2.5\text{A when } \delta < 50\%$$

$$I_{CL} = 1.67 (2 - \delta) \text{ when } \delta \geq 50\%$$

(Refer to Electrical Characteristics.)

$I_{OUT}$  = maximum output current

$V_{IN(min)}$  = minimum input voltage =  $V_{IN} - V_{SW}$

$\delta$  = duty cycle

$V_{OUT}$  = required output voltage

$V_F$  = D1 forward voltage drop

For the example in Figure 1.

$$I_{OUT} = 0.25\text{A}$$

$$I_{CL} = 1.67 (2 - 0.662) = 2.24\text{A}$$

$$V_{IN(min)} = 4.18\text{V}$$

$$\delta = 0.662$$

$$V_{OUT} = 12.0\text{V}$$

$$V_F = 0.36\text{V (@ .26A, } 70^\circ\text{C)}$$

then:

$$I_{OUT} \leq \frac{\left(\frac{2.235}{2}\right) \times 4.178 \times 0.662}{12}$$

$$I_{OUT} \leq 0.258\text{A}$$

This value is greater than the 0.25A output current requirement, so we can proceed to find the minimum inductance value of L1 for discontinuous operation at  $P_{OUT}$ .

$$(2) \quad L1 \geq \frac{(V_{IN} \delta)^2}{2P_{OUT} f_{SW}}$$

where:

$$P_{OUT} = 12 \times 0.25 = 3W$$

$$f_{SW} = 1 \times 10^5 \text{ Hz (100kHz)}$$

For our practical example:

$$L1 \geq \frac{(4.178 \times 0.662)^2}{2 \times 3.0 \times 1 \times 10^5}$$

$$L1 \geq 12.4 \mu\text{H (use } 15 \mu\text{H)}$$

Equation (3) solves for L1's maximum current value.

$$(3) \quad I_{L1(\text{peak})} = \frac{V_{IN} T_{ON}}{L1}$$

where:

$$T_{ON} = \delta / f_{SW} = 6.62 \times 10^{-6} \text{ sec}$$

$$I_{L1(\text{peak})} = \frac{4.178 \times 6.62 \times 10^{-6}}{15 \times 10^{-6}}$$

$$I_{L1(\text{peak})} = 1.84A$$

Use a 15μH inductor with a peak current rating of at least 2A.

**Flyback Conversion**

Flyback converter topology may be used in low power applications where voltage isolation is required or whenever the input voltage can be less than or greater than the output voltage. As with the step-up converter the inductor (transformer primary) current can be continuous or discontinuous. Discontinuous operation is recommended.

Figure 2 shows a practical flyback converter design using the MIC2171.

**Switch Operation**

During Q1's on time (Q1 is the internal NPN transistor—see block diagrams), energy is stored in T1's primary inductance. During Q1's off time, stored energy is partially discharged into C4 (output filter capacitor). Careful selection of a low ESR capacitor for C4 may provide satisfactory output ripple voltage making additional filter stages unnecessary.

C1 (input capacitor) may be reduced or eliminated if the MIC2171 is located near a low impedance voltage source.

**Output Diode**

The output diode allows T1 to store energy in its primary inductance (D2 non-conducting) and release energy into C4 (D2 conducting). The low forward voltage drop of a Schottky diode minimizes power loss in D2.

**Frequency Compensation**

A simple frequency compensation network consisting of R3 and C2 prevents output oscillations.

High impedance output stages (transconductance type) in the MIC2171 often permit simplified loop-stability

solutions to be connected to circuit ground, although a more conventional technique of connecting the components from the error amplifier output to its inverting input is also possible.

**Voltage Clipper**

Care must be taken to minimize T1's leakage inductance, otherwise it may be necessary to incorporate the voltage clipper consisting of D1, R4, and C3 to avoid second breakdown (failure) of the MIC2171's internal power switch.

**Discontinuous Mode Design**

When designing a discontinuous flyback converter, first determine whether the device can safely handle the peak primary current demand placed on it by the output power. Equation (8) finds the maximum duty cycle required for a given input voltage and output power. If the duty cycle is greater than 0.8, discontinuous operation cannot be used.

$$(8) \quad \delta \geq \frac{2P_{OUT}}{I_{CL}(V_{IN(\text{min})} - V_{SW})}$$

For a practical example let: (see Figure 2)

$$P_{OUT} = 5.0V \times 0.5A = 2.5W$$

$$V_{IN} = 4.0V \text{ to } 6.0V$$

$$I_{CL} = 2.5A \text{ when } \delta < 50\%$$

$$1.67 (2 - \delta) \text{ when } \delta \geq 50\%$$

then:

$$V_{IN(\text{min})} = V_{IN} - (I_{CL} \times R_{SW})$$

$$V_{IN(\text{min})} = 4 - 0.78V$$

$$V_{IN(\text{min})} = 3.22V$$

$$\delta \geq 0.74 (74\%), \text{ less than } 0.8 \text{ so discontinuous is permitted.}$$

A few iterations of equation (8) may be required if the duty cycle is found to be greater than 50%.

Calculate the maximum transformer turns ratio a, or N<sub>PRI</sub>/N<sub>SEC</sub>, that will guarantee safe operation of the MIC2171 power switch.

$$(9) \quad a \leq \frac{V_{CE} F_{CE} - V_{IN(\text{max})}}{V_{SEC}}$$

where:

a = transformer maximum turns ratio

V<sub>CE</sub> = power switch collector to emitter maximum voltage

F<sub>CE</sub> = safety derating factor (0.8 for most commercial and industrial applications)

V<sub>IN(max)</sub> = maximum input voltage

V<sub>SEC</sub> = transformer secondary voltage (V<sub>OUT</sub> + V<sub>F</sub>)



For the practical example:

$$V_{CE} = 65V \text{ max. for the MIC2171}$$

$$F_{CE} = 0.8$$

$$V_{SEC} = 5.6V$$

then:

$$a \leq \frac{65 \times 0.8 - 6.0}{5.6}$$

$$a \leq 8.2 (N_{PRI}/N_{SEC})$$

Next, calculate the maximum primary inductance required to store the needed output energy with a power switch duty cycle of 55%.

$$(10) \quad L_{PRI} \geq \frac{0.5f_{SW} V_{IN(min)}^2 T_{ON}^2}{P_{OUT}}$$

where:

$L_{PRI}$  = maximum primary inductance

$f_{SW}$  = device switching frequency (100kHz)

$V_{IN(min)}$  = minimum input voltage

$T_{ON}$  = power switch on time

then:

$$L_{PRI} \geq \frac{0.5 \times 1 \times 10^5 \times (3.22)^2 \times (7.4 \times 10^{-6})^2}{2.5}$$

$$L_{PRI} \geq 11.4\mu H$$

Use a 12μH primary inductance to overcome circuit inefficiencies.

To complete the design the inductance value of the secondary is found which will guarantee that the energy stored in the transformer during the power switch on time will be completely discharged into the output during the off-time. This is necessary when operating in discontinuous-mode.

$$(11) \quad L_{SEC} \leq \frac{0.5f_{SW} V_{SEC}^2 T_{OFF}^2}{P_{OUT}}$$

where:

$L_{SEC}$  = maximum secondary inductance

$T_{OFF}$  = power switch off time

then:

$$L_{SEC} \leq \frac{0.5 \times 1 \times 10^5 \times (5.41)^2 \times (2.6 \times 10^{-6})^2}{2.5}$$

$$L_{SEC} \leq 7.9\mu H$$

Finally, recalculate the transformer turns ratio to insure that it is less than the value earlier found in equation (9).

$$(12) \quad a \leq \sqrt{\frac{L_{PRI}}{L_{SEC}}}$$

then:

$$a \leq \sqrt{\frac{11.4}{7.9}} = 1.20$$

This ratio is less than the ratio calculated in equation (9). When specifying the transformer it is necessary to know the primary peak current which must be withstood without saturating the transformer core.

$$(13) \quad I_{PEAK(pri)} = \frac{V_{IN(min)} T_{ON}}{L_{PRI}}$$

so:

$$I_{PEAK(pri)} = \frac{3.22 \times 7.6 \times 10^{-6}}{L_{PRI}}$$

$$I_{PEAK(pri)} = 2.1A$$

Now find the minimum reverse voltage requirement for the output rectifier. This rectifier must have an average current rating greater than the maximum output current of 0.5A.

$$(14) \quad V_{BR} \geq \frac{V_{IN(max)} + (V_{OUT} a)}{F_{BR} a}$$

where:

$V_{BR}$  = output rectifier maximum peak reverse voltage rating

$a$  = transformer turns ratio (1.2)

$F_{BR}$  = reverse voltage safety derating factor (0.8)

then:

$$V_{BR} \geq \frac{6.0 + (5.0 \times 1.2)}{0.8 \times 1.2}$$

$$V_{BR} \geq 12.5V$$

A 1N5817 will safely handle voltage and current requirements in this example.

### Forward Converters

Micrel's MIC2171 can be used in several circuit configurations to generate an output voltage which is less than the input voltage (buck or step-down topology). Figure 6 shows the MIC2171 in a voltage step-down application. Because of the internal architecture of these devices, more external components are required to implement a step-down regulator than with other devices offered by Micrel (refer to the LM257x or MIC457x family of buck switchers). However, for step-down conversion requiring a transformer (forward), the MIC2171 is a good choice.

A 12V to 5V step-down converter using transformer isolation (forward) is shown in Figure 6. Unlike the isolated flyback converter which stores energy in the primary inductance during the controller's on-time and releases it to the load during the off-time, the forward converter transfers energy to the output during the on-

time, using the off-time to reset the transformer core. In the application shown, the transformer core is reset by the tertiary winding discharging T1's peak magnetizing current through D2.

For most forward converters the duty cycle is limited to 50%, allowing the transformer flux to reset with only two times the input voltage appearing across the power switch. Although during normal operation this circuit's duty cycle is well below 50%, the MIC2172 has a maximum duty cycle capability of 90%. If 90% was required during operation (start-up and high load currents), a complete reset of the transformer during the

off-time would require the voltage across the power switch to be ten times the input voltage. This would limit the input voltage to 6V or less for forward converter applications.

To prevent core saturation, the application given here uses a duty cycle limiter consisting of Q1, C4 and R3. Whenever the MIC2171 exceeds a duty cycle of 50%, T1's reset winding current turns Q1 on. This action reduces the duty cycle of the MIC2171 until T1 is able to reset during each cycle.

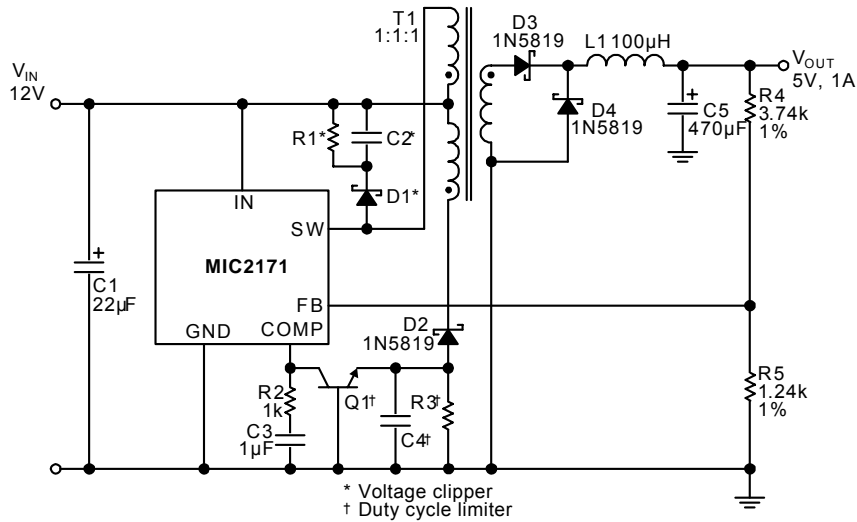
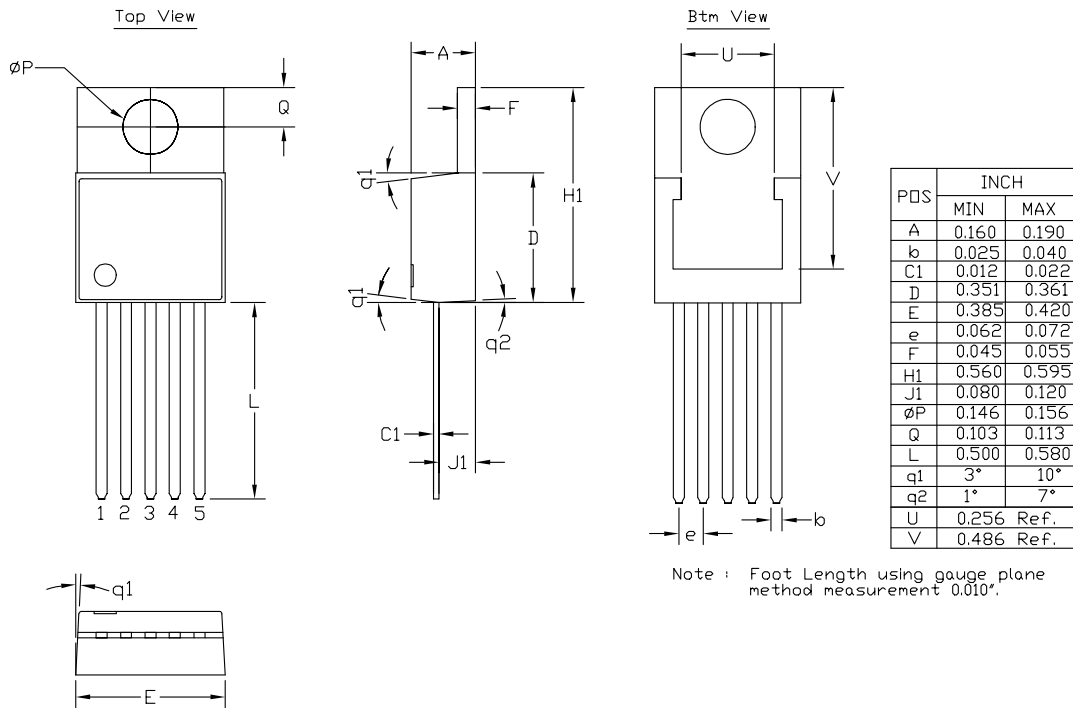
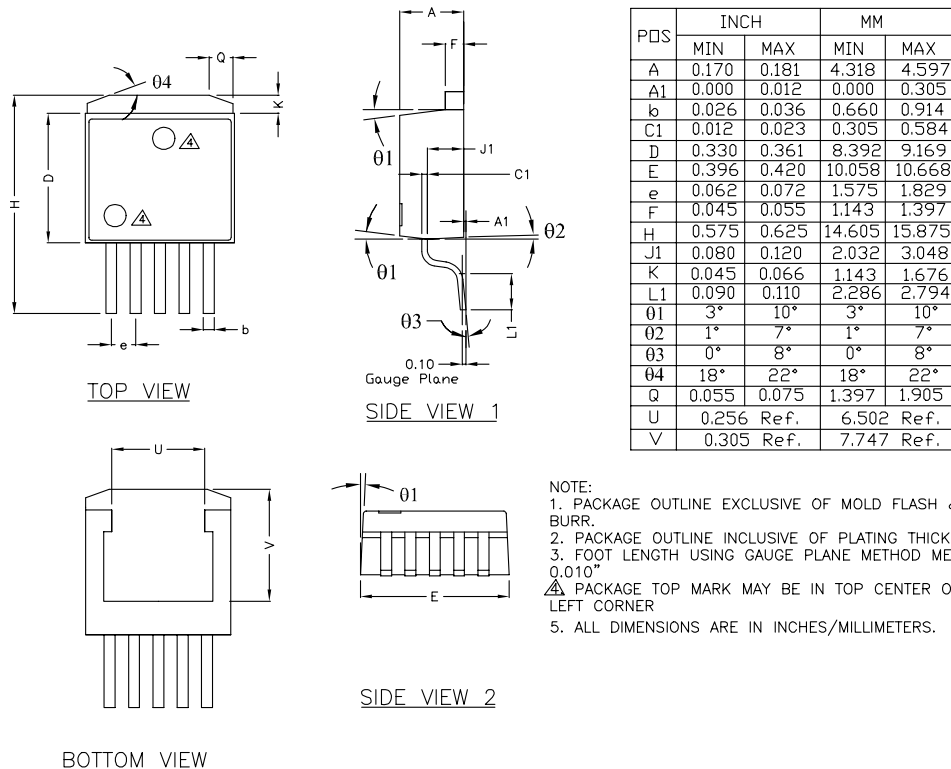

Figure 6. MIC2171 Forward Converter

### Package Information



**5-Pin TO-220 (T)**



**5-Pin TO-263 (U)**

---

**MICREL, INC. 2180 FORTUNE DRIVE SAN JOSE, CA 95131 USA**TEL +1 (408) 944-0800 FAX +1 (408) 474-1000 WEB <http://www.micrel.com>

The information furnished by Micrel in this data sheet is believed to be accurate and reliable. However, no responsibility is assumed by Micrel for its use. Micrel reserves the right to change circuitry and specifications at any time without notification to the customer.

Micrel Products are not designed or authorized for use as components in life support appliances, devices or systems where malfunction of a product can reasonably be expected to result in personal injury. Life support devices or systems are devices or systems that (a) are intended for surgical implant into the body or (b) support or sustain life, and whose failure to perform can be reasonably expected to result in a significant injury to the user. A Purchaser's use or sale of Micrel Products for use in life support appliances, devices or systems is a Purchaser's own risk and Purchaser agrees to fully indemnify Micrel for any damages resulting from such use or sale.

© 2005 Micrel, Incorporated.

# Mouser Electronics

Authorized Distributor

Click to View Pricing, Inventory, Delivery & Lifecycle Information:

[Microchip:](#)

[MIC2171WU](#) [MIC2171WT](#) [MIC2171WU-TR](#)