

THIS DRAWING IS UNPUBLISHED. RELEASED FOR PUBLICATION
 © COPYRIGHT - By - ALL RIGHTS RESERVED.

REVISIONS				
P	LTR	DESCRIPTION	DATE	APVD
D		REVISED PER ECO-14-016691	05NOV2014	NK RH
D1		REVISED PER ECO-16-017354	09MAR2017	RK AS

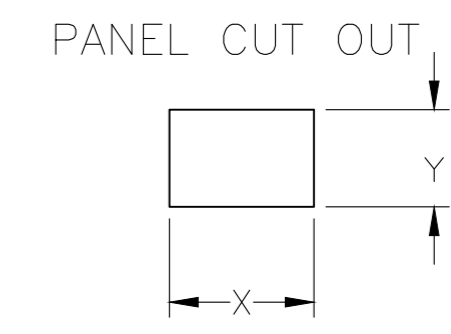

2.00-3.00 [.079-.118]	21.2+0.1 [.835+.004]	37.0+0.2 [1.457+.008]
1.25-2.00 [.049-.079]	21.2+0.1 [.835+.004]	36.8+0.2 [1.449+.008]
.075-1.25 [.030-.049]	21.2+0.1 [.835+.004]	36.6+0.2 [1.441+.008]
PANEL THICKNESS	Y	X

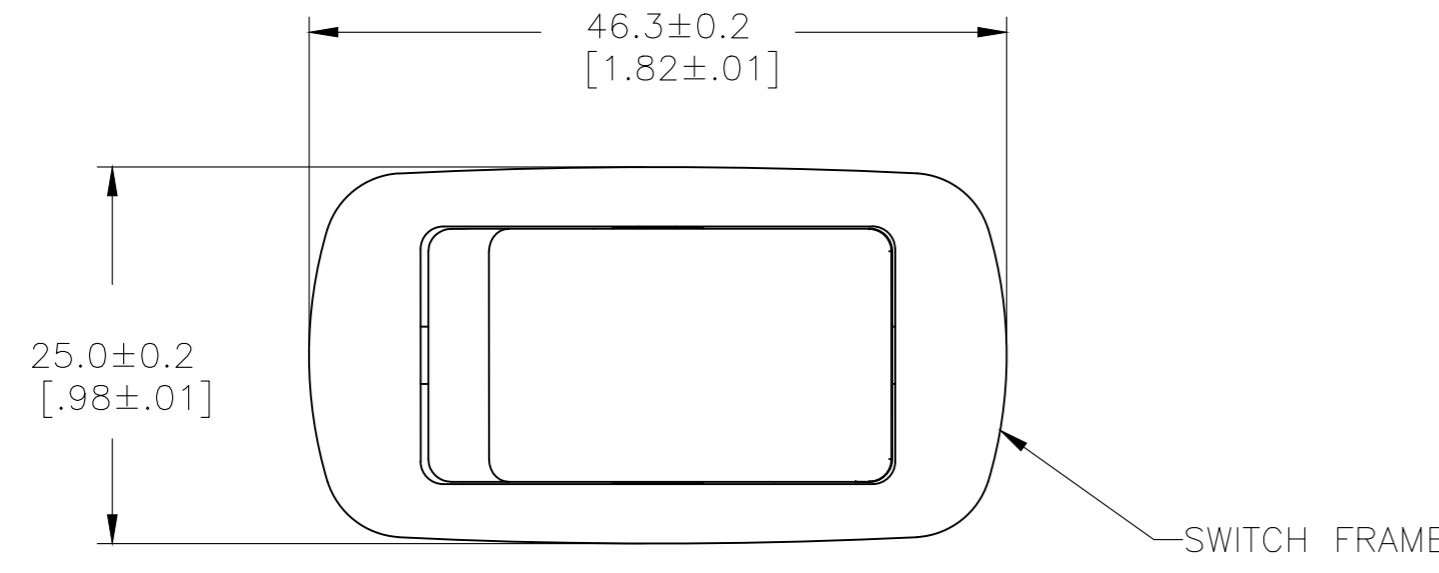
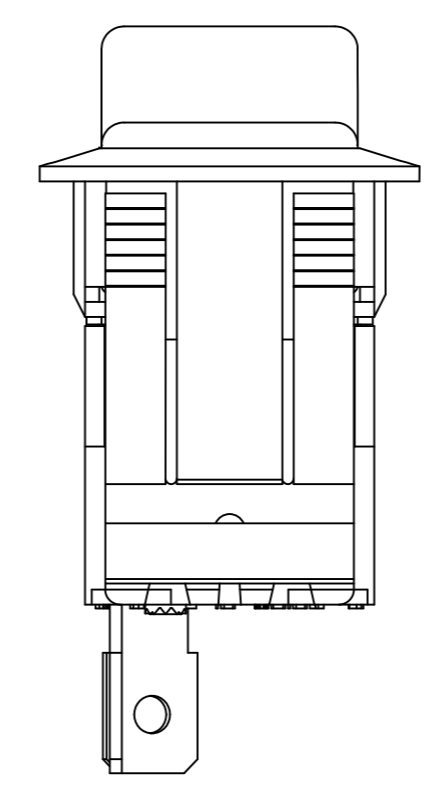
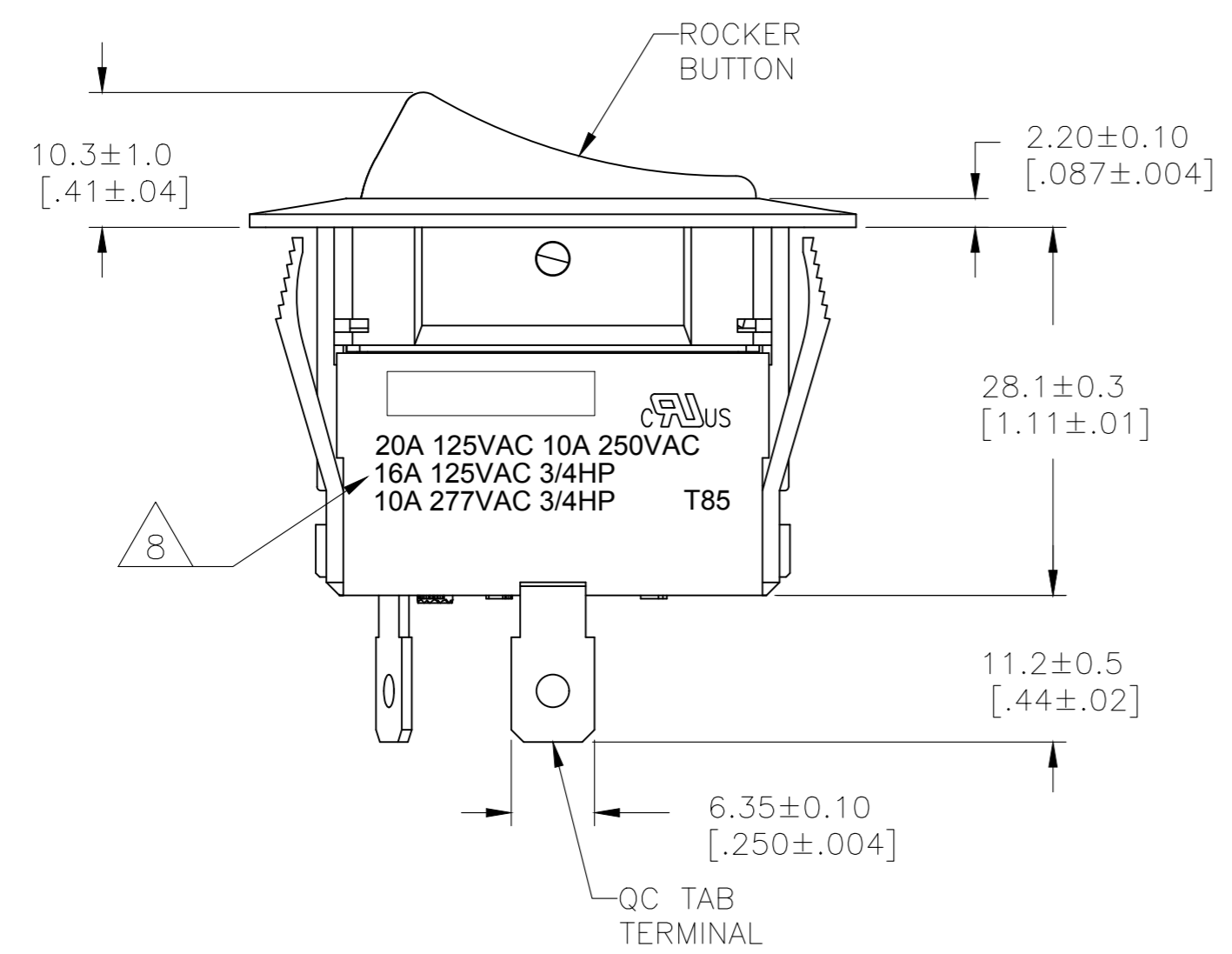

SWITCH FUNCTION A1
 CIRCUIT DIAGRAM

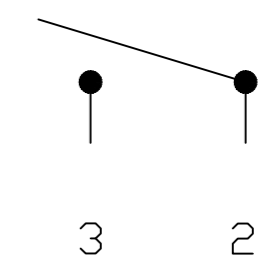

1571095-1
 SHOWN

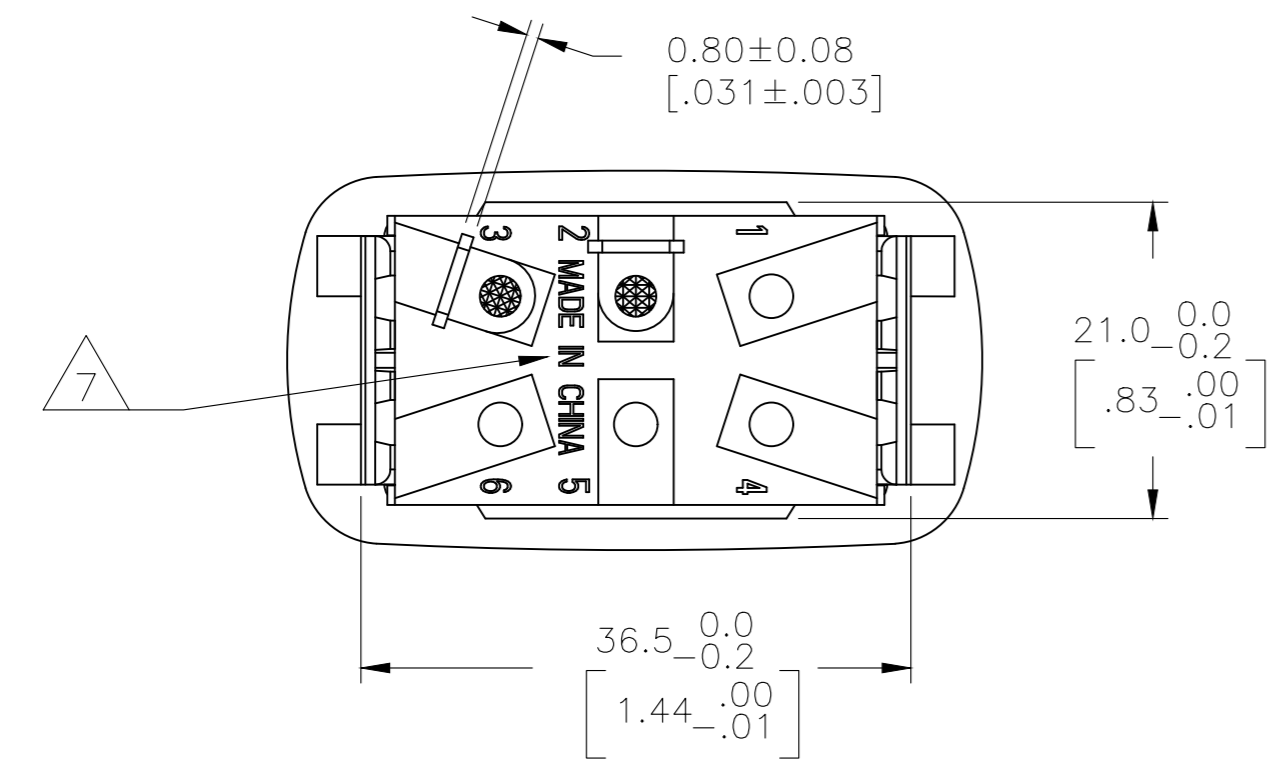

THIS DRAWING IS A CONTROLLED DOCUMENT.		DWN M.BINNER 25FEB2002	TE Connectivity	
DIMENSIONS: mm [INCHES]		CHK D.ROHDE 16NOV05		
TOLERANCES UNLESS OTHERWISE SPECIFIED:		APVD D.ROHDE 16NOV05	NAME POWER ROCKER SWITCH, 21.2mm X 36.6mm MIN PANEL SIZE SPST, NON-ILLUMINATED	
0 PLC ± - 1 PLC ± - 2 PLC ± - 3 PLC ± - 4 PLC ± - ANGLES ± -		PRODUCT SPEC	SIZE CAGE CODE DRAWING NO RESTRICTED TO	
MATERIAL		APPLICATION SPEC	A2 00779 C-1571095	
FINISH		WEIGHT	SCALE 2:1 SHEET 1 of 4 REV D1	
1		CUSTOMER DRAWING		

THIS DRAWING IS UNPUBLISHED. RELEASED FOR PUBLICATION
 © COPYRIGHT - By - ALL RIGHTS RESERVED.

REVISIONS				
P	LTR	DESCRIPTION	DATE	APVD
-	-	SEE SHEET 1	-	-

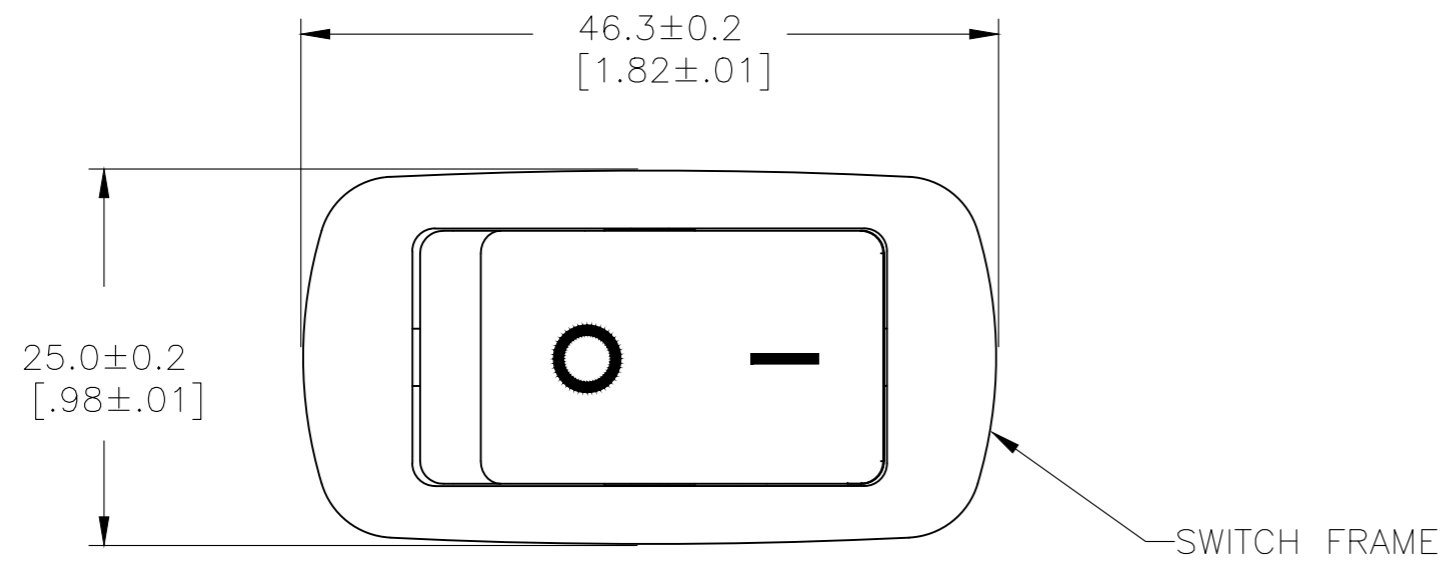

PANEL CUT OUT

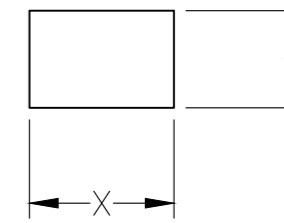

2.00-3.00 [.079-.118]	21.2+0.1 [.835+.004]	37.0+0.2 [1.457+.008]
1.25-2.00 [.049-.079]	21.2+0.1 [.835+.004]	36.8+0.2 [1.449+.008]
.075-1.25 [.030-.049]	21.2+0.1 [.835+.004]	36.6+0.2 [1.441+.008]
PANEL THICKNESS	Y	X

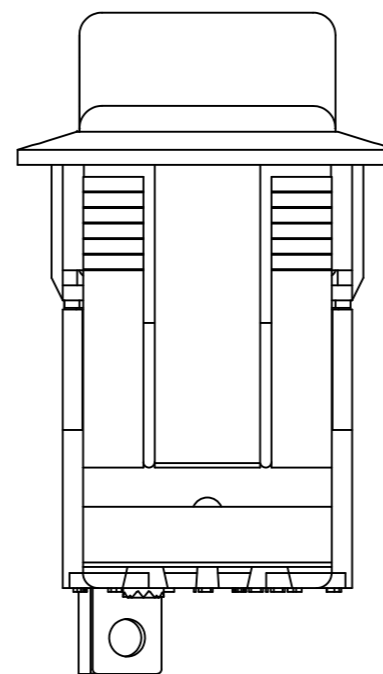
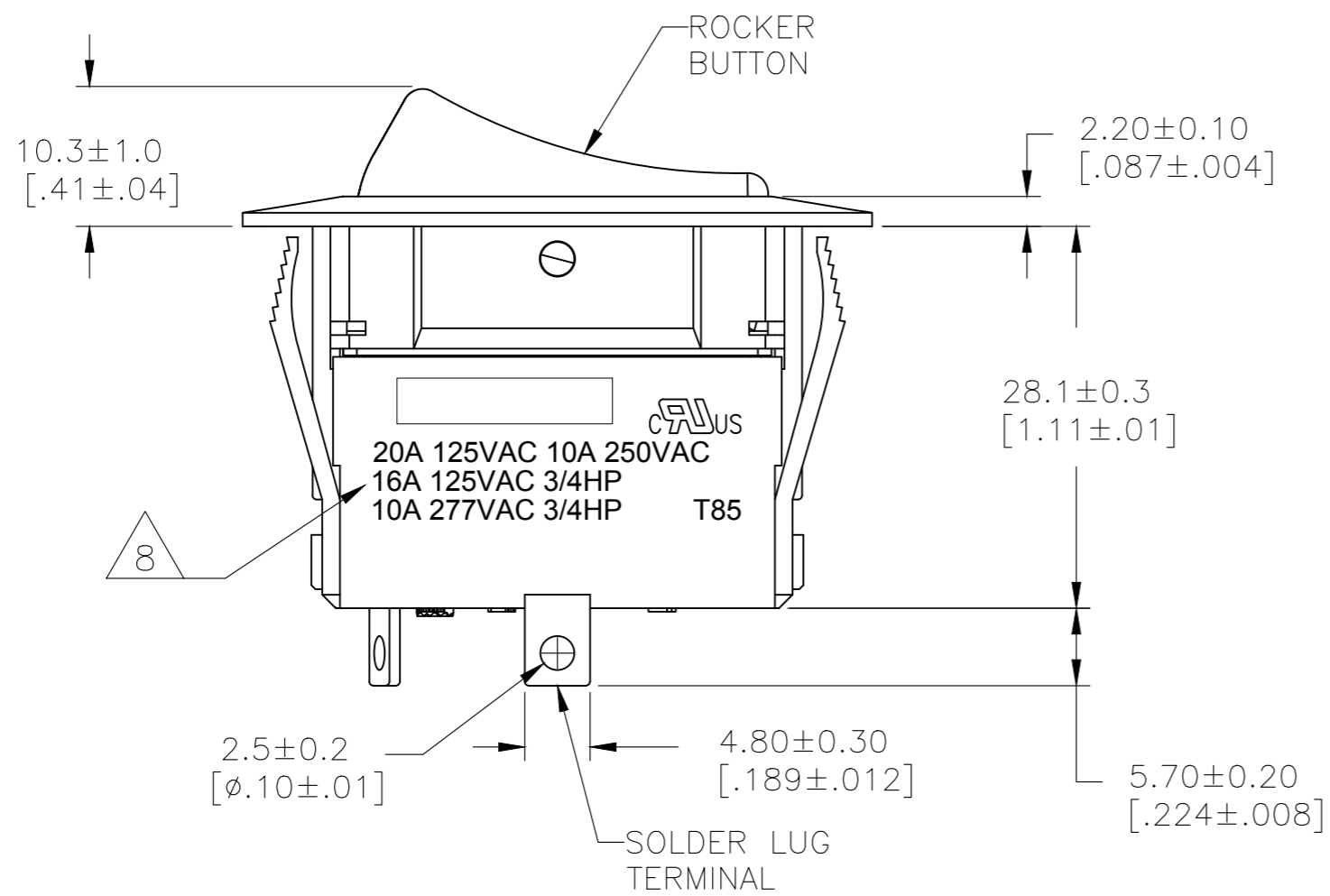

SWITCH FUNCTION A1
CIRCUIT DIAGRAM

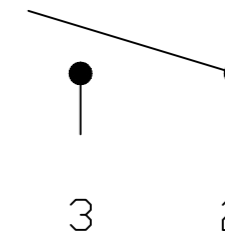

1571095-5
SHOWN

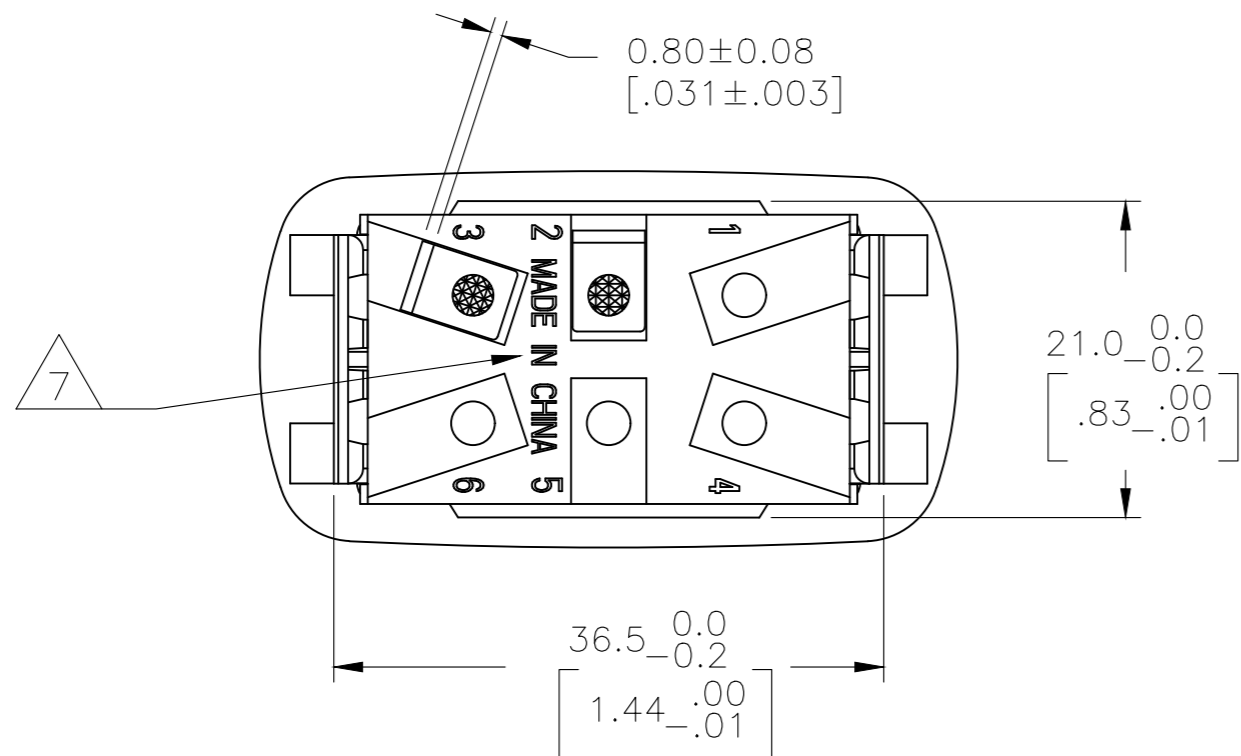

THIS DRAWING IS A CONTROLLED DOCUMENT.		DWN M.BINNER 25FEB2002	TE Connectivity	
DIMENSIONS: mm [INCHES]		CHK D.ROHDE 16NOV05		
TOLERANCES UNLESS OTHERWISE SPECIFIED:		APVD D.ROHDE 16NOV05	NAME POWER ROCKER SWITCH, 21.2mm X 36.6mm MIN PANEL SIZE SPST, NON-ILLUMINATED	
0 PLC ± - 1 PLC ± - 2 PLC ± - 3 PLC ± - 4 PLC ± - ANGLES ± -		PRODUCT SPEC -	SIZE A2	
MATERIAL		APPLICATION SPEC -	CAGE CODE 00779	DRAWING NO. C-1571095
FINISH		WEIGHT -	RESTRICTED TO -	
1		CUSTOMER DRAWING		SCALE 2:1 SHEET 2 of 4 REV D1

4

3

2

1

THIS DRAWING IS UNPUBLISHED. RELEASED FOR PUBLICATION
 © COPYRIGHT - By - ALL RIGHTS RESERVED.

REVISIONS				
P	LTR	DESCRIPTION	DATE	APVD
-	-	SEE SHEET 1	-	-

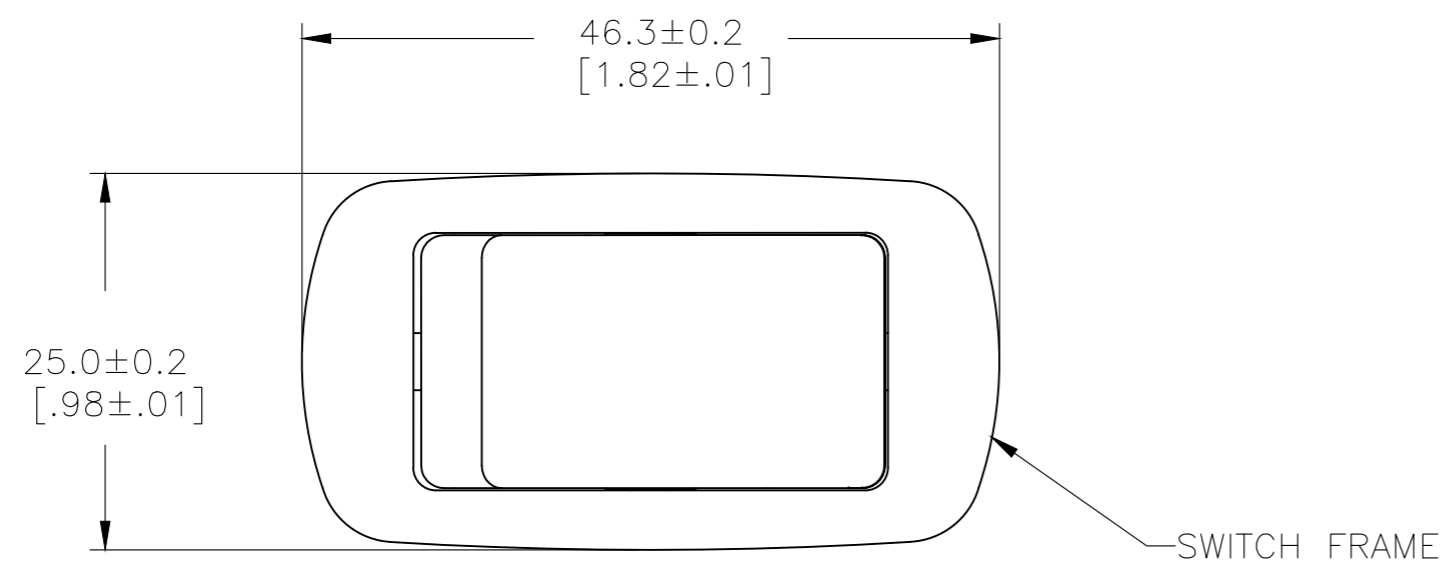

PANEL CUT OUT

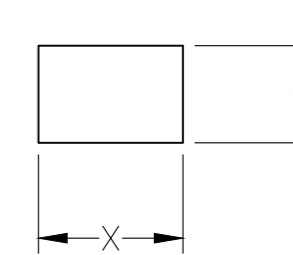

2.00-3.00 [.079-.118]	21.2+0.1 [.835+.004]	37.0+0.2 [1.457+.008]
1.25-2.00 [.049-.079]	21.2+0.1 [.835+.004]	36.8+0.2 [1.449+.008]
.075-1.25 [.030-.049]	21.2+0.1 [.835+.004]	36.6+0.2 [1.441+.008]
PANEL THICKNESS	Y	X

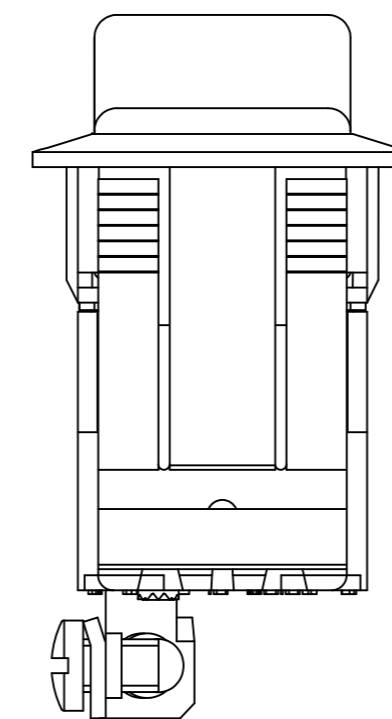
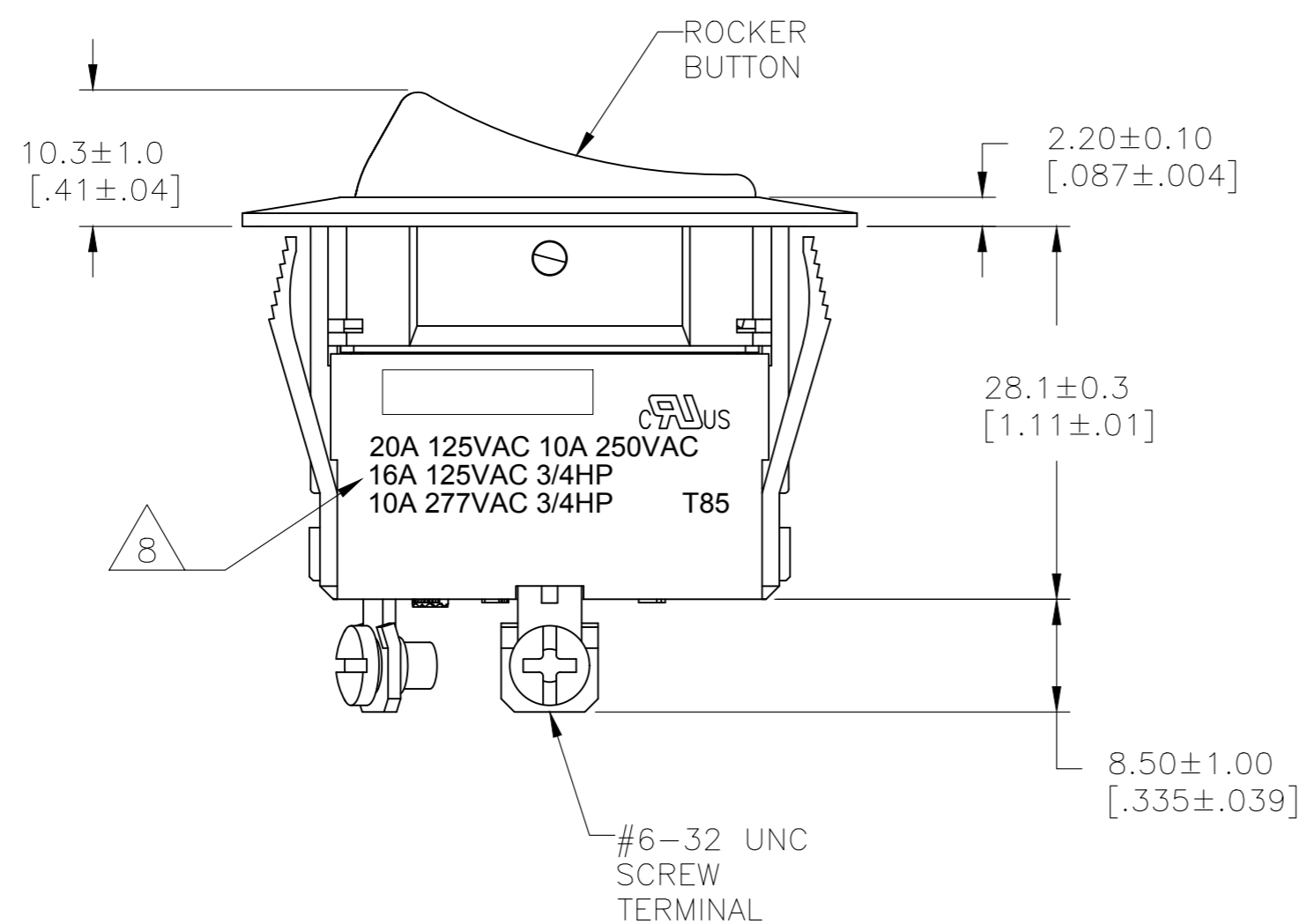

SWITCH FUNCTION A1
CIRCUIT DIAGRAM

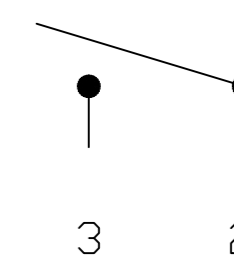

OBSOLETE 1571095-9
SHOWN

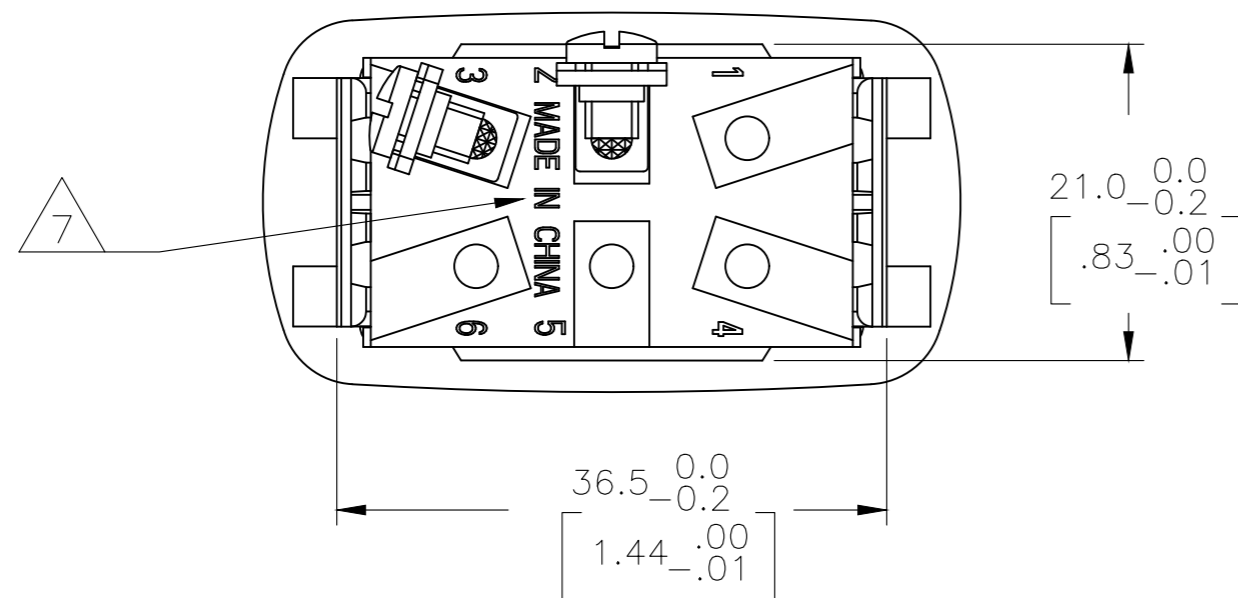

THIS DRAWING IS A CONTROLLED DOCUMENT.		DWN M.BINNER 25FEB2002	TE Connectivity	
DIMENSIONS: mm [INCHES]		CHK D.ROHDE 16NOV05		
TOLERANCES UNLESS OTHERWISE SPECIFIED:		APVD D.ROHDE 16NOV05	NAME POWER ROCKER SWITCH, 21.2mm X 36.6mm MIN PANEL SIZE SPST, NON-ILLUMINATED	
0 PLC ± - 1 PLC ± - 2 PLC ± - 3 PLC ± - 4 PLC ± - ANGLES ± -		PRODUCT SPEC	SIZE A2	
MATERIAL		APPLICATION SPEC	CAGE CODE 00779	DRAWING NO C-1571095
FINISH		WEIGHT	RESTRICTED TO	
1		CUSTOMER DRAWING		SCALE 2:1 SHEET 3 of 4 REV D1

REVISIONS				
P	LTR	DESCRIPTION	DATE	APVD
-	-	SEE SHEET 1	-	-

1 MATERIALS:
 ROCKER BUTTON, FRAME & HOUSING: NYLON 66, UL 94 V-2.
 PLUNGER: PHENOLIC
 SEAL: SILICONE RUBBER
 SCREW TERMINAL, ACTIVE CONTACTOR, CONTACTOR SUPPORT: COPPER ALLOY PER ASTM B152
 QC & SOLDER TERMINAL: COPPER ALLOY PER ASTM B036
 SPRING: STEEL WIRE
 CONTACTS: SILVER-TIN OXIDE

2 FINISH:
 CONTACTOR SUPPORT, ACTIVE CONTACTOR: 1.01µm [.000040] MIN SILVER
 QC TERMINAL: 1.27µm [.000050] MIN NICKEL
 SOLDER TERMINAL: 1.27µm [.000050] MIN TIN

3 ELECTRICAL SPECIFICATIONS:
 CURRENT AND VOLTAGE: 6
 CONTACT RESISTANCE (INITIAL): <50mΩ
 DIELECTRIC STRENGTH (INITIAL): >1000 VAC, 1 MINUTE
 INSULATION RESISTANCE (INITIAL): >100MΩ MIN (500VDC BETWEEN OPEN CONTACTS)
 ELECTRICAL LIFE ENDURANCE: >6000 OPERATIONS, VOLTAGE DROP: <100mV
 TEMPERATURE RISE AT TERMINALS: <30°C, 6000 OPERATIONS
 (AMBIENT CONDITIONS: 25±2°C AND 65±5%R.H)

4 MECHANICAL SPECIFICATIONS:
 ACTUATING FORCE: 400g MIN, 1200g MAX
 OPERATING LIFE ENDURANCE: >100,000 OPERATIONS
 TERMINAL RETENTION FORCE: >9kg- SOLDER LUG
 >9kg- QC TAB
 >6.8kg- #6-32 SCREW

5 ENVIRONMENTAL SPECIFICATIONS:
 AMBIENT TEMPERATURE: -20°C TO +85°C
 DEGREE OF PROTECTION: IP66

6 20A 125VAC, 10A 250VAC/16A 125VAC, 3/4HP/ 10A 277VAC, 3/4HP

7 COUNTRY OF ORIGIN AND TERMINAL IDENTIFICATION NUMBERS MOLDED APPROXIMATELY AS SHOWN ON THE SWITCH HOUSING.

8 ELECTRICAL RATINGS, APPROVED AGENCY LOGOS AND THE TE CONNECTIVITY LOGO LASER MARKED APPROXIMATELY AS SHOWN ON THE SWITCH HOUSING.

9 COMPONENT RECOGNIZED TO US & CANADIAN STANDARDS, UL FILE NO. E46765.

10 ROHS 2002/95/EC COMPLIANT

ALCOSWITCH PART NUMBER

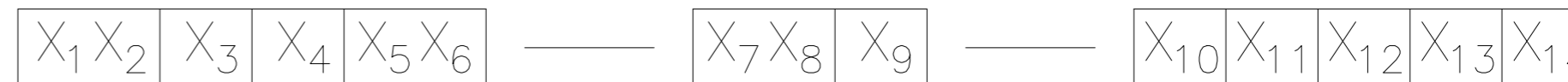

SWITCH TYPE: X1X2 = PR - POWER ROCKER
 PANEL CUT OUT SIZE: X3 = C - 21.2x36.6 MIN [.835x1.441]
 NUMBER OF POLES: X4 = S - SINGLE
 SWITCH FUNCTION: X5X6 = A1-ON-OFF, WITH OPAQUE, SINGLE-COLOR ROCKER BUTTON.

SECONDARY ROCKER COLOR: X12 = Ø - NOT APPLICABLE

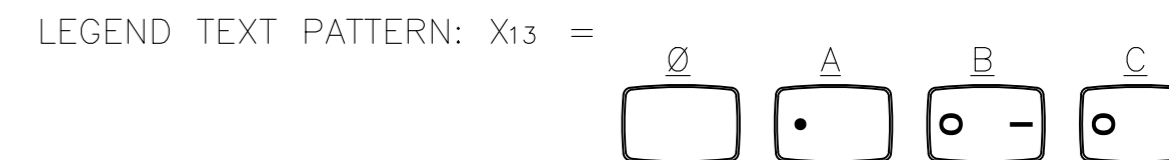

CURRENT RATING: X7X8 = 20 - 6
 TERMINAL TYPE: X9 = E - QC TAB
 L - SOLDER LUG
 S - #6-32 UNC SCREW
 FRAME COLOR: X10 = B - BLACK
 W - WHITE

LEGEND TEXT COLOR: X14 = Ø - NOT APPLICABLE
 G - GREEN
 R - RED
 B - BLACK
 W - WHITE

ROCKER COLOR: X11 = B - BLACK
 G - GREEN
 R - RED
 W - WHITE
 Y - YELLOW

OBSOLETE	3	PRCSA1-20S-BB0CW	1-1571095-1
	3	PRCSA1-20S-BB0BW	1-1571095-0
	3	PRCSA1-20S-BB000	1571095-9
	2	PRCSA1-20L-BR000	1571095-8
	1	PRCSA1-20F-BR000	1571095-7
OBSOLETE	2	PRCSA1-20L-BB0CW	1571095-6
	2	PRCSA1-20L-BB0BW	1571095-5
	2	PRCSA1-20L-BB000	1571095-4
	1	PRCSA1-20F-BB0CW	1571095-3
	1	PRCSA1-20F-BB0BW	1571095-2
	1	PRCSA1-20F-BB000	1571095-1
	SHEET REF	ALCOSWITCH PART NUMBER	PART NUMBER

THIS DRAWING IS A CONTROLLED DOCUMENT.		DWN M.BINNER 25FEB2002	TE Connectivity	
DIMENSIONS: mm [INCHES]		CHK D.ROHDE 16NOV05	NAME POWER ROCKER SWITCH, 21.2mm X 36.6mm MIN PANEL SIZE SPST, NON-ILLUMINATED	
TOLERANCES UNLESS OTHERWISE SPECIFIED: 0 PLC ± - 1 PLC ± - 2 PLC ± - 3 PLC ± - 4 PLC ± - ANGLES ± -		APVD D.ROHDE 16NOV05	RESTRICTED TO	
MATERIAL		PRODUCT SPEC	SIZE A2	CAGE CODE 00779
FINISH		APPLICATION SPEC	DRAWING NO C-1571095	SCALE 2:1
1		WEIGHT	SHEET 4 of 4	
2		CUSTOMER DRAWING		REV D1

Mouser Electronics

Authorized Distributor

Click to View Pricing, Inventory, Delivery & Lifecycle Information:

[TE Connectivity:](#)

[PRCSA1-20F-BB0BW](#)