

Spezifikation für Freigabe / specification for release

Kunde / customer :
 Artikelnummer / part number : **749801122R**
 Bezeichnung : **LAN-Übertrager WE-RJ45LAN 10/100Base-T**
 description : **LAN-Transformer WE-RJ45LAN 10/100Base-T**



DATUM / DATE : 2016-02-24

A Mechanische Abmessungen / dimensions :

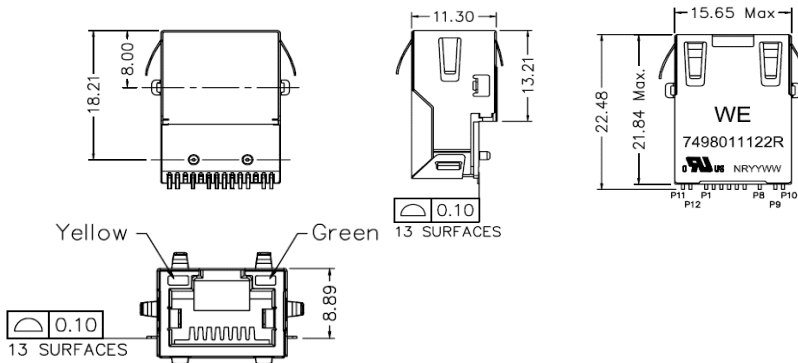

B Lötpad / soldering spec. :

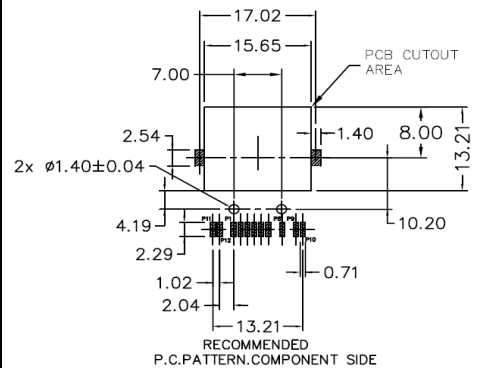

C Elektrische Eigenschaften / electrical properties :

Eigenschaften / properties	Testbedingungen / test conditions		Wert / value	Einheit / unit	tol.
Induktivität / Inductance	100kHz / 100mV @ 8mA DC-Bias	OCL	350	µH	min.
Übersetzungsverhältnis / Turns ratio	100kHz / 100mV	TR	1 : 1	Tx	2%
			1 : 1	Rx	
Insertion Loss	1-100MHz	IL	-1.0	dB	max.
Return Loss	1-30MHz	RL	-18	dB	min.
	30-60 MHz		-14		
	60-80MHz		-12		
	80-100MHz		-10		
Common Mode Rejection	1-30MHz	CMR	-40	dB	min.
	30-60MHz		-37		
	60-100MHz		-35		
Crosstalk	1-60MHz	CT	-35	dB	min.
	60-100MHz		-35		

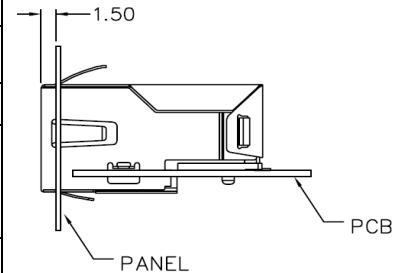

D Prüfgeräte / test equipment :

Agilent 4395A Network Analyzer

E Testbedingungen / test conditions :

Luftfeuchtigkeit / humidity: 33%
 Umgebungstemperatur / temperature: +25°C

F Werkstoffe & Zulassungen / material & approvals :

Basismaterial / base material: Ferrit/ ferrite
 Draht / wire: QPN 180
 Kontaktmaterial/ contact plating: 100% tin w. nickel underplating
 30µ" gold plating on contact area
 Gehäuse / housing: Thermoplastic UL 94V-0
 LED: 1,8-2,5 V/ 20mA
 Shield: 50µ" nickel over 0.008" cooper alloy

G Eigenschaften / general specifications :

Betriebstemp. / operating temperature: -40°C - + 85°C
 Hochspannungsprüfung / Hipot test: 2250VDC 1min.
 Geeignet für 10/100Base-TX gemäß IEEE 802.3u /
 Compliant with IEEE 802.3u for 10/100Base-TX-Applications
 Auto MDIX fähig / Auto MDIX capable
 UL File: E330599

Freigabe erteilt / general release:

	Kunde / customer			
.....			
Datum / date	Unterschrift / signature			
	Würth Elektronik			
.....			
Geprüft / checked	Kontrolliert / approved	MMai	Revision 00	2016-02-24
		Name	Änderung / modification	Datum / date

Würth Elektronik eiSos GmbH & Co.KG

D-74638 Waldenburg · Max-Eyth-Straße 1 - 3 · Germany · Telefon (+49) (0) 7942 - 945 - 0 · Telefax (+49) (0) 7942 - 945 - 400
<http://www.we-online.com>

Spezifikation für Freigabe / specification for release

Kunde / customer :
 Artikelnummer / part number : **7498011122R**
 Bezeichnung : **LAN-Übertrager WE-RJ45LAN 10/100Base-T**
 description : **LAN-Transformer WE-RJ45LAN 10/100Base-T**



DATUM / DATE : 2016-02-24

H Schaltbild / Schematics :

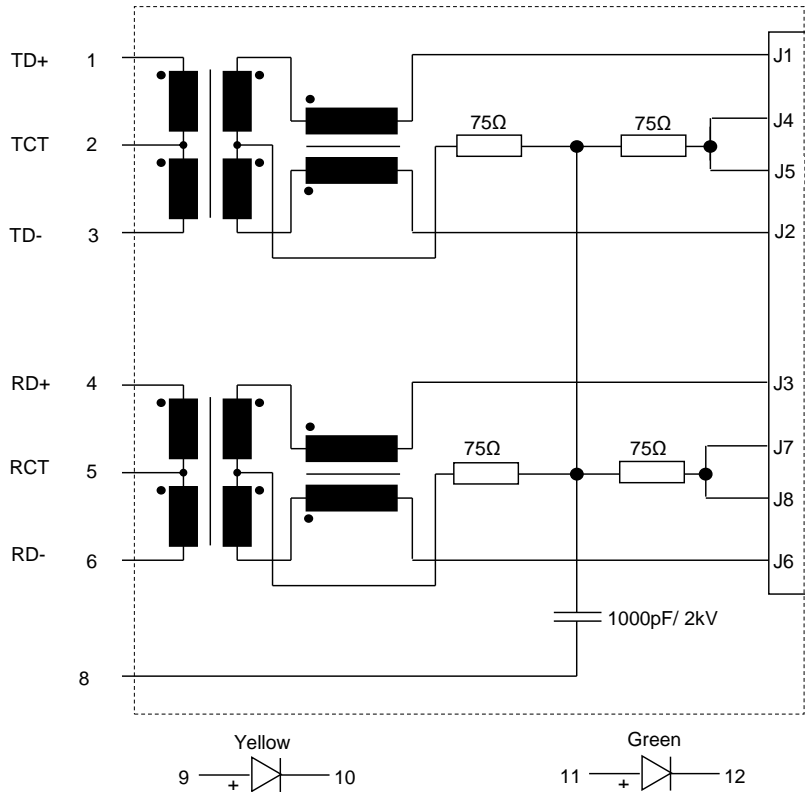

Freigabe erteilt / general release:	Kunde / customer			
.....			
Datum / date	Unterschrift / signature			
.....	Würth Elektronik			
.....			
Geprüft / checked	Kontrolliert / approved	MMai	Revision 00	2016-02-24
		Name	Änderung / modification	Datum / date

Würth Elektronik eiSos GmbH & Co.KG

D-74638 Waldenburg · Max-Eyth-Straße 1 - 3 · Germany · Telefon (+49) (0) 7942 - 945 - 0 · Telefax (+49) (0) 7942 - 945 - 400
<http://www.we-online.com>

Spezifikation für Freigabe / specification for release

Kunde / customer :
 Artikelnummer / part number : **7498011122R**
 Bezeichnung : **LAN-Übertrager WE-RJ45LAN 10/100Base-T**
 description : **LAN-Transformer WE-RJ45LAN 10/100Base-T**



DATUM / DATE : 2016-02-24

I Verpackungsspezifikation / package specification :

Reel:

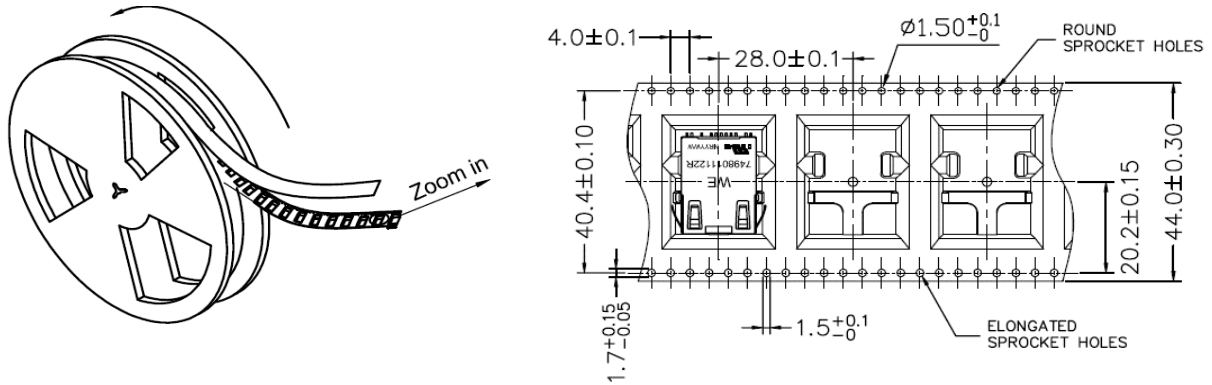

Carton:

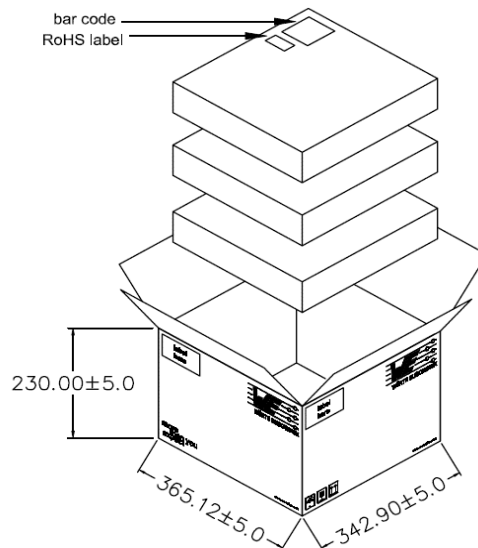

Packing Quantity:

reel = 100 pcs
 carton = 300 pcs

dimensions in mm

Freigabe erteilt / general release:	Kunde / customer			
.....			
Datum / date	Unterschrift / signature			
.....	Würth Elektronik			
.....			
Geprüft / checked	Kontrolliert / approved	MMai	Revision 00	2016-02-24
		Name	Änderung / modification	Datum / date

This electronic component has been designed and developed for usage in general electronic equipment. Before incorporating this component into any equipment where higher safety and reliability is especially required or if there is the possibility of direct damage or injury to human body, for example in the range of aerospace, aviation, nuclear control, submarine, transportation, (automotive control, train control, ship control), transportation signal, disaster prevention, medical, public information network etc. Würth Elektronik eiSos GmbH must be informed before the design-in stage. In addition, sufficient reliability evaluation checks for safety must be performed on every electronic component which is used in electrical circuits that require high safety and reliability functions or performance.

Würth Elektronik eiSos GmbH & Co.KG

D-74638 Waldenburg · Max-Eyth-Straße 1 · 3 · Germany · Telefon (+49) (0) 7942 - 945 - 0 · Telefax (+49) (0) 7942 - 945 - 400
<http://www.we-online.com>

Mouser Electronics

Authorized Distributor

Click to View Pricing, Inventory, Delivery & Lifecycle Information:

[Wurth Electronics:](#)

[7498011122R](#)