

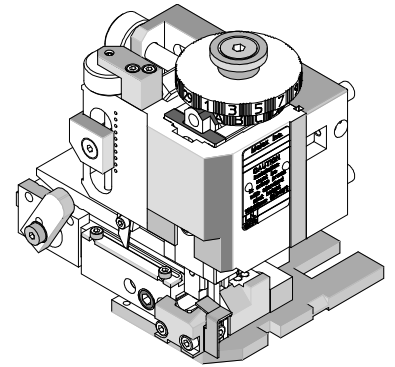

FineAdjust Applicator Specification Sheet Order No. 63867-8000



FEATURES

- Quick punch removal with the push of a button for fast and easy tooling change
- Applicator designed to industry standard mounting and shut height 135.80mm (5.346")
- Quick set-up time; plus the crimp height, track and feed adjustments can be set without removing the applicator from the press
- Fine adjustment allows users to achieve target with little effort by adjusting in increments of .015mm (.0006") for conductor crimp height and .063mm (.0025") for insulation height
- Independent adjustment rings allow users to quickly adjust the conductor or insulation crimp height without affecting each other
- Directly adapts to most automatic wire processing machines

SCOPE

Products: Contact Pin and Socket 4.64mm (.183") Hooded Crimp Terminals, 14-18 AWG.
See 63867-8100 and 63867-8200 for different insulation diameters out of this range.

Terminal Series No.	Terminal Order No.		Wire Size		Insulation Diameter		Strip Length	
			AWG	mm ²	mm	In.	mm	In.
84590	84590-0022	84590-0032	14-18	2.08-0.82	1.91-2.41	.075-.095	3.81-5.08	.175-.225
	84590-0023	84590-0033						
	84590-0028	84590-0034						
	84590-0029	84590-0035						

DEFINITION OF TERMS

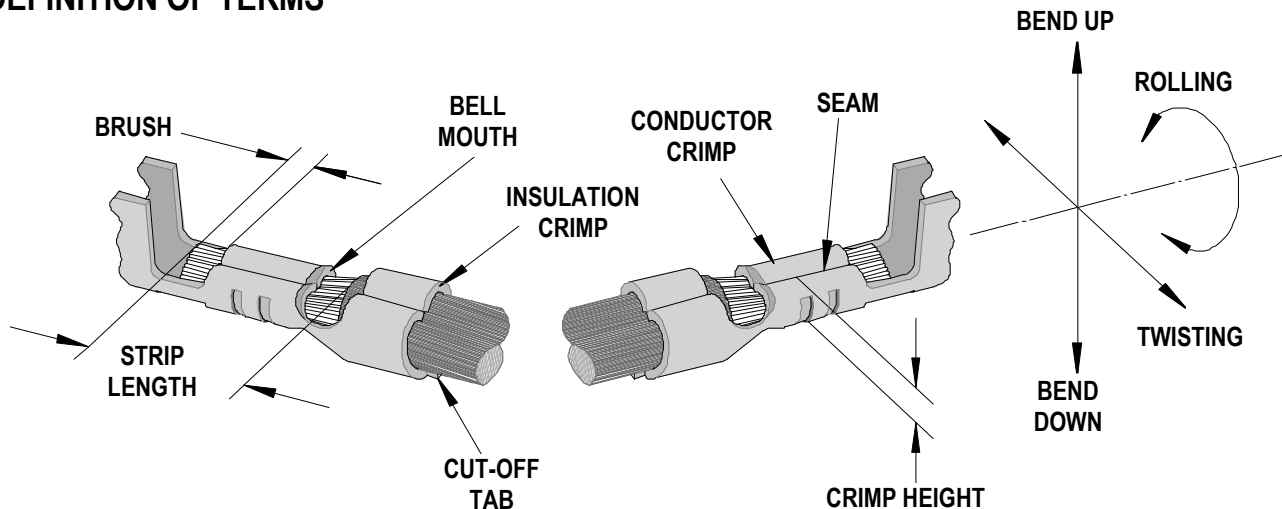

The above terminal drawing is a generic terminal representation. It is not an image of any terminal listed in the scope.

CRIMP SPECIFICATION

Terminal Series No.	Bell mouth		Cut-off Tab Maximum		Conductor Brush	
	mm	In.	mm	In.	mm	In.
84590	0.30-0.60	.012-.024	0.50	.020	0.30-0.80	.012-.032

Terminal Series No.	Bend up	Bend down	Twist	Roll	Punch Width (Ref)				Seam Seam shall not be open and no wire allowed out of the crimping area
					Conductor		Insulation		
	Degree	Degree	mm	In	mm	In			
84590	3 °	3 °	4 °	8 °	2.50	.098	2.70	.106	

After crimping, the crimp profiles should measure the following:

Terminal Order No.	Wire Size		Conductor				Pull Force Minimum	
			Crimp Height		Crimp Width (Ref)			
	AWG	mm ²	mm	In.	mm	In.	N	Lb.
84590-0022	14	2.08	1.73-1.81	.068-.071	2.48-2.63	.098-.104	111.3	25
	16	1.31	1.48-1.56	.058-.061	2.48-2.63	.098-.104	111.3	25
	18	0.82	1.36-1.44	.053-.056	2.48-2.63	.098-.104	111.3	25
84590-0023	14	2.08	1.73-1.81	.068-.071	2.48-2.63	.098-.104	111.3	25
	16	1.31	1.48-1.56	.058-.061	2.48-2.63	.098-.104	111.3	25
	18	0.82	1.36-1.44	.053-.056	2.48-2.63	.098-.104	111.3	25
84590-0028	14	2.08	1.73-1.81	.068-.071	2.48-2.63	.098-.104	111.3	25
	16	1.31	1.48-1.56	.058-.061	2.48-2.63	.098-.104	111.3	25
	18	0.82	1.36-1.44	.053-.056	2.48-2.63	.098-.104	111.3	25
84590-0029	14	2.08	1.73-1.81	.068-.071	2.48-2.63	.098-.104	111.3	25
	16	1.31	1.48-1.56	.058-.061	2.48-2.63	.098-.104	111.3	25
	18	0.82	1.36-1.44	.053-.056	2.48-2.63	.098-.104	111.3	25
84590-0032	14	2.08	1.80-1.88	.071-.074	2.48-2.63	.098-.104	111.3	25
	16	1.31	1.55-1.63	.061-.064	2.48-2.63	.098-.104	111.3	25
	18	0.82	1.45-1.53	.057-.060	2.48-2.63	.098-.104	111.3	25
84590-0033	14	2.08	1.80-1.88	.071-.074	2.48-2.63	.098-.104	111.3	25
	16	1.31	1.55-1.63	.061-.064	2.48-2.63	.098-.104	111.3	25
	18	0.82	1.45-1.53	.057-.060	2.48-2.63	.098-.104	111.3	25
84590-0034	14	2.08	1.80-1.88	.071-.074	2.48-2.63	.098-.104	111.3	25
	16	1.31	1.55-1.63	.061-.064	2.48-2.63	.098-.104	111.3	25
	18	0.82	1.45-1.53	.057-.060	2.48-2.63	.098-.104	111.3	25
84590-0035	14	2.08	1.80-1.88	.071-.074	2.48-2.63	.098-.104	111.3	25
	16	1.31	1.55-1.63	.061-.064	2.48-2.63	.098-.104	111.3	25
	18	0.82	1.45-1.53	.057-.060	2.48-2.63	.098-.104	111.3	25

T Tool Qualification Notes:

- 33 This Applicator was qualified to the above specifications with MIL-W-16878E wire for 14 AWG, UL 1061 wire for 16 AWG and UL 1007 wire for 18 AWG.
- 33 Pull Force should be measured with no influence from the insulation crimp.
- 33 The above specifications are guidelines to an optimum crimp.

PARTS LIST

FineAdjust Applicator 63867-8000				
Item	Order No	Engineering No.	Description	Quantity
Perishable Tooling				
	63867-8070	63867-8070	Tool Kit (All "Y" Items)	REF
1	63444-2521	63444-2521	Conductor Punch	1 Y
2	63445-2574	63445-2574	Conductor Anvil	1 Y
3	63454-0072	63454-0072	Insulation Punch	1 Y
4	63445-2887	63445-2887	Insulation Anvil	1 Y
5	63443-0037	63443-0037	Cut-Off Plunger Front	1 Y
6	63443-0038	63443-0038	Plunger Retainer Front	1 Y
Other Components				
7	11-17-0022	1739-21	Compression Spring	1
8	11-18-4083	60707-8	Front Cover	1
9	11-18-4456	60739A109	Wire Hold Down Spring	1
10	11-24-1149	4996-37	Shank	1
11	63443-0009	63443-0009	Scrap Chute Front	1
12	63443-0021	63443-0021	Lower Tooling Key	1
13	63443-0090	63443-0090	Wire Stop	1
14	63443-2801	63443-2801	Plunger Striker Front	1
15	63443-1168	63443-1168	Blade-Wire Hold Down	1
16	63443-1169	63443-1169	Terminal Hold Down	1
17	63443-2517	63443-2517	Anvil Mount	1
18	63443-2914	63443-2914	Wire Hold-Down Plunger	1
19	63443-6121	63443-6121	Rear Cover	1
20	63600-0021	63600-0021	Spring-Compression	1
21	63600-2673	63600-2673	Mini Rod	1
22	63700-0539	63700-0539	Cut-off Plunger Spring	1
Frame				
23	63800-4901	63800-4901	Top	1
24	63801-3281	63801-3281	Base	1
25	63801-4650	63801-4650	Track	1
Hardware				
26	N/A	N/A	M3 by 6 Long SHCS	2**
27	N/A	N/A	M4 by 6 Long SHCS	2**
28	N/A	N/A	M4 by 12 Long BHCS	2**
29	N/A	N/A	M4 by 50 Long SHCS	2**
30	N/A	N/A	M5 by 12 Long SHCS	1**
31	N/A	N/A	2mm by 5 Long Roll Pin	1**
32	N/A	N/A	3mm by 6 Long Roll Pin	1**
33	N/A	N/A	#5-40 by 3/8" Long SHCS	1**
34	N/A	N/A	#10-32 by 3/8" Long Flat Point SSS	1**
35	N/A	N/A	#10-32 Hex Jam Nut	1**

** Available from an industrial supply company such as MSC (1-800-645-7270).

Assembly Drawing

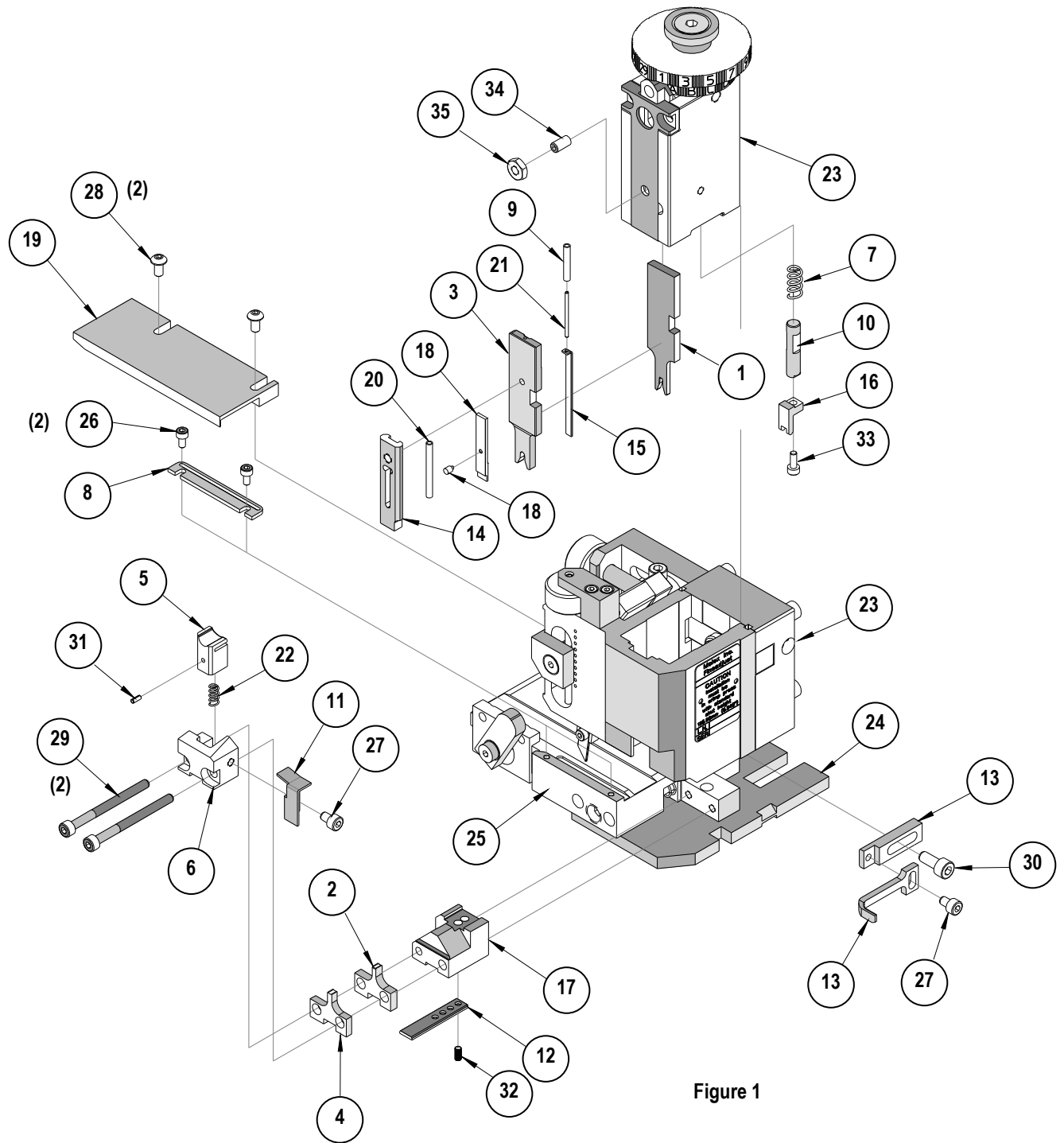

Figure 1

NOTES

1. Molex recommends an extra perishable tooling kit be maintained at your facility.
2. Verify tooling alignment by manually cycling the press and Applicator before crimping under power. Check that all screws are tight.
3. Slugs, Terminals, Dirt and Oil should be kept clear of work area.
4. Wear safety glasses at all times.
5. For recommended maintenance refer to the FineAdjust Manual.

CAUTION: This applicator should only be used in a press with a shut height of 135.80 mm (5.346"). Tooling damage could result at a lower setting.

CAUTION: To prevent injury never operate this Applicator without the guards supplied with the press or wire-processing machine in place. Reference the press or wire processing manufacturer's instruction manual.

CAUTION: Molex crimp specifications are valid only when used with Molex terminals, applicators and tooling.

Americas Headquarters Lisle, Illinois 60532 U.S.A. 1-800-78MOLEX amerinfo@molex.com	Far East North Headquarters Yamato, Kanagawa, Japan 81-462-65-2324 feninfo@molex.com	Far East South Headquarters Jurong, Singapore 65-6-268-6868 fesinfo@molex.com	European Headquarters Munich, Germany 49-89-413092-0 eurinfo@molex.com	Corporate Headquarters 2222 Wellington Ct. Lisle, IL 60532 U.S.A. 630-969-4550 Fax: 630-969-1352
---	--	---	--	---

Visit our Web site at <http://www.molex.com>

Mouser Electronics

Authorized Distributor

Click to View Pricing, Inventory, Delivery & Lifecycle Information:

[Molex:](#)

[63867-8070](#)