

Apr.1.2019 Copyright 2019 HIROSE ELECTRIC CO., LTD. All Rights Reserved.
 In case of consideration for using Automotive equipment / device which demand high reliability, kindly contact our sales window correspondents.

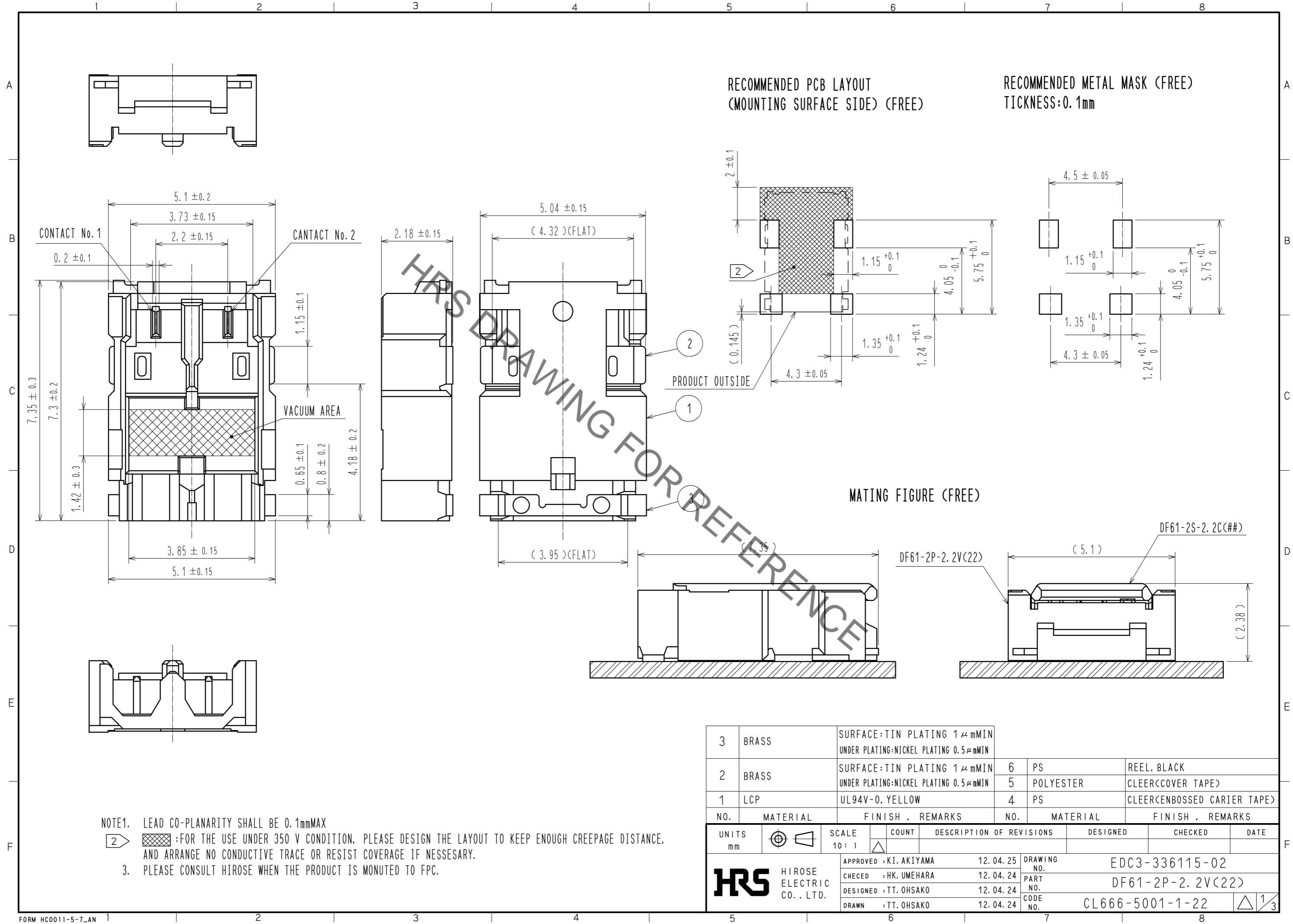

NOTE1. LEAD CO-PLANARITY SHALL BE 0.1mmMAX

2. :FOR THE USE UNDER 350 V CONDITION. PLEASE DESIGN THE LAYOUT TO KEEP ENOUGH CREEPAGE DISTANCE. AND ARRANGE NO CONDUCTIVE TRACE OR RESIST COVERAGE IF NECESSARY.

3. PLEASE CONSULT HIROSE WHEN THE PRODUCT IS MONUTED TO FPC.

Apr.1.2019 Copyright 2019 HIROSE ELECTRIC CO., LTD. All Rights Reserved.
 In case of consideration for using Automotive equipment / device which demand high reliability, kindly contact our sales window correspondents.

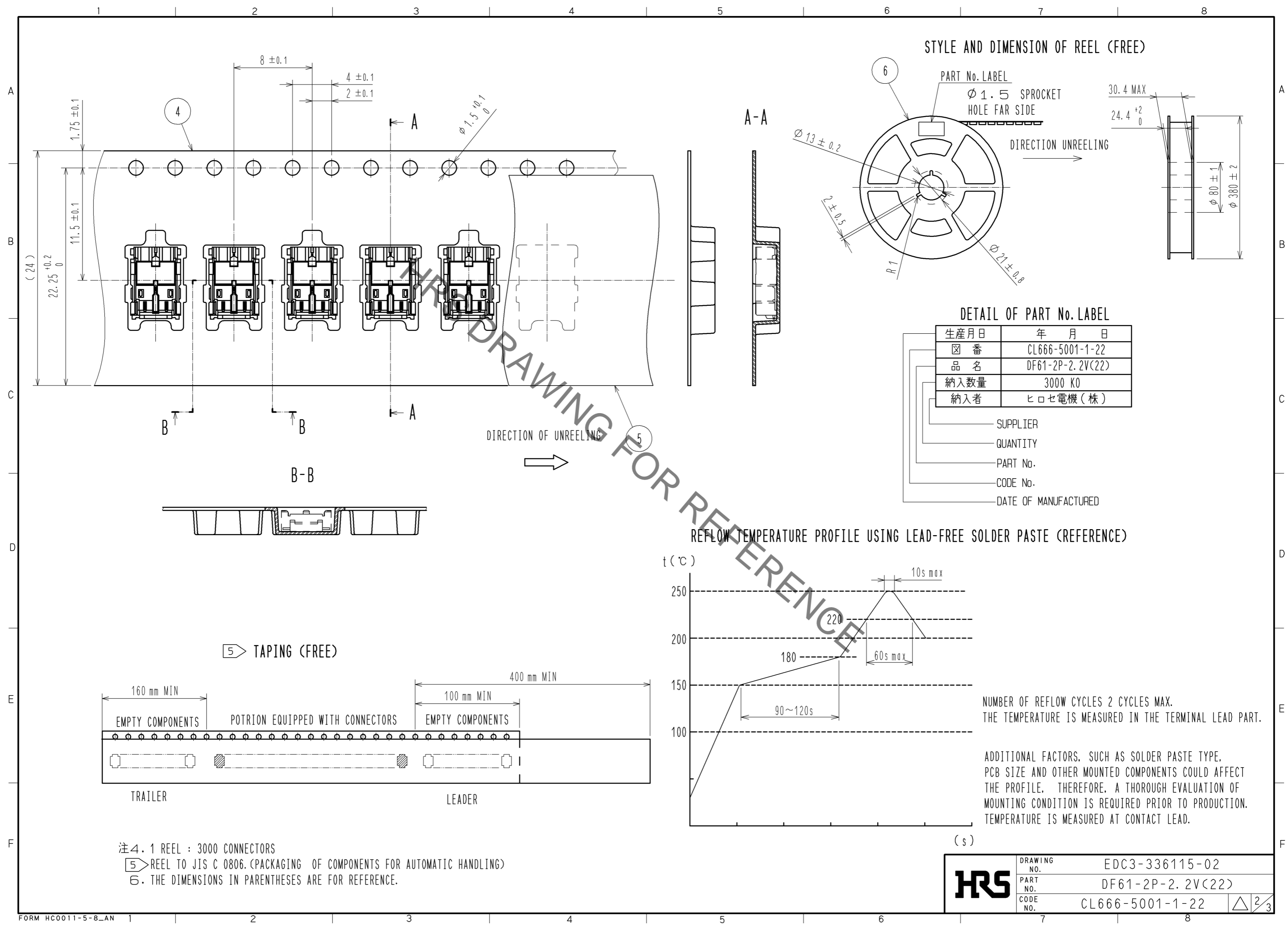

STYLE AND DIMENSION OF REEL (FREE)

PART No. LABEL
 Ø 1.5 SPROCKET HOLE FAR SIDE

DETAIL OF PART No. LABEL

生産月日	年 月 日
☒ 番	CL666-5001-1-22
品名	DF61-2P-2.2V(22)
納入数量	3000 K0
納入者	ヒロセ電機(株)

- SUPPLIER
- QUANTITY
- PART No.
- CODE No.
- DATE OF MANUFACTURED

REFLOW TEMPERATURE PROFILE USING LEAD-FREE SOLDER PASTE (REFERENCE)

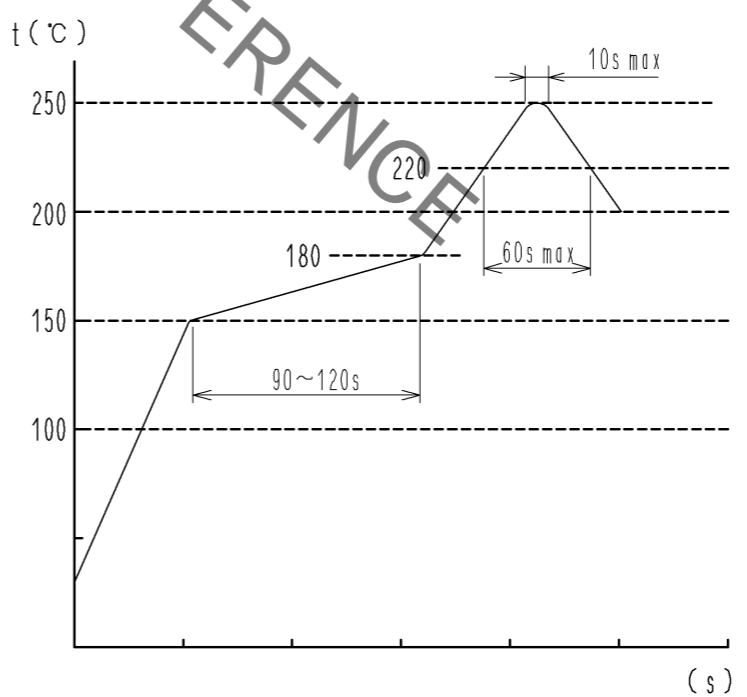

NUMBER OF REFLOW CYCLES 2 CYCLES MAX.
 THE TEMPERATURE IS MEASURED IN THE TERMINAL LEAD PART.

ADDITIONAL FACTORS, SUCH AS SOLDER PASTE TYPE, PCB SIZE AND OTHER MOUNTED COMPONENTS COULD AFFECT THE PROFILE. THEREFORE, A THOROUGH EVALUATION OF MOUNTING CONDITION IS REQUIRED PRIOR TO PRODUCTION. TEMPERATURE IS MEASURED AT CONTACT LEAD.

- 注4. 1 REEL : 3000 CONNECTORS
- ⑤ REEL TO JIS C 0806. (PACKAGING OF COMPONENTS FOR AUTOMATIC HANDLING)
- ⑥ THE DIMENSIONS IN PARENTHESES ARE FOR REFERENCE.

HRS	DRAWING NO.	EDC3-336115-02
	PART NO.	DF61-2P-2.2V(22)
	CODE NO.	CL666-5001-1-22
		△ 2/3

DF61 Series Mating / Unmating Operation Instruction

Mating

① By positioning the convexity of the socket sides to the header concavity, align the centers of the socket and the header in pitch direction.

② Slightly press the socket down at cable side to tilted angle.

③ Press down at the lever side with stabilizing the cable side to insert. Mating completes.

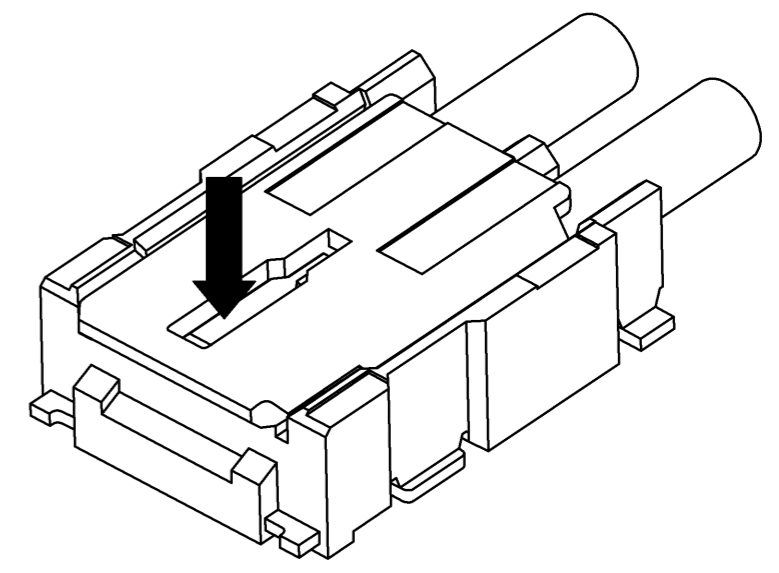
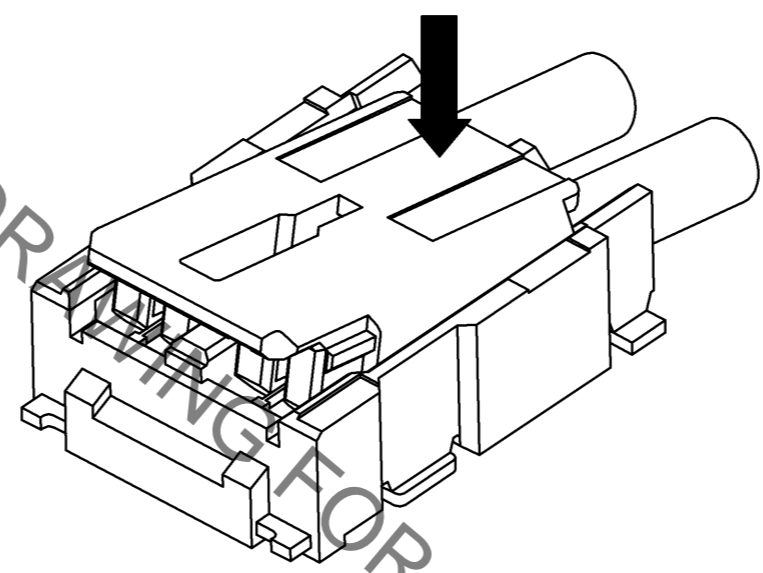
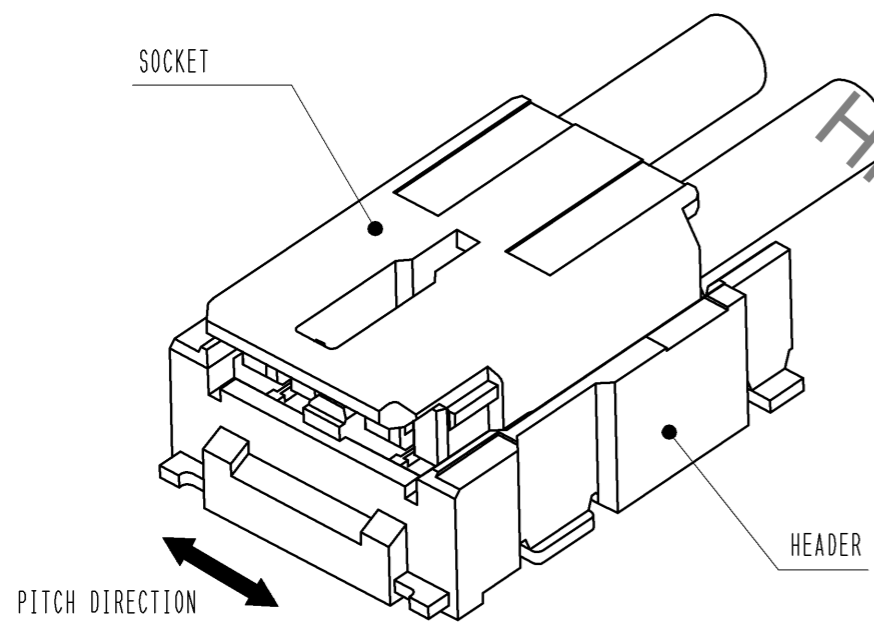

Unmating

① Hook the lever with finger nail.

② Lift up to the upper direction and friction lock is released.

③ Lift up to the upper direction and positive lock is released. Removal completes.

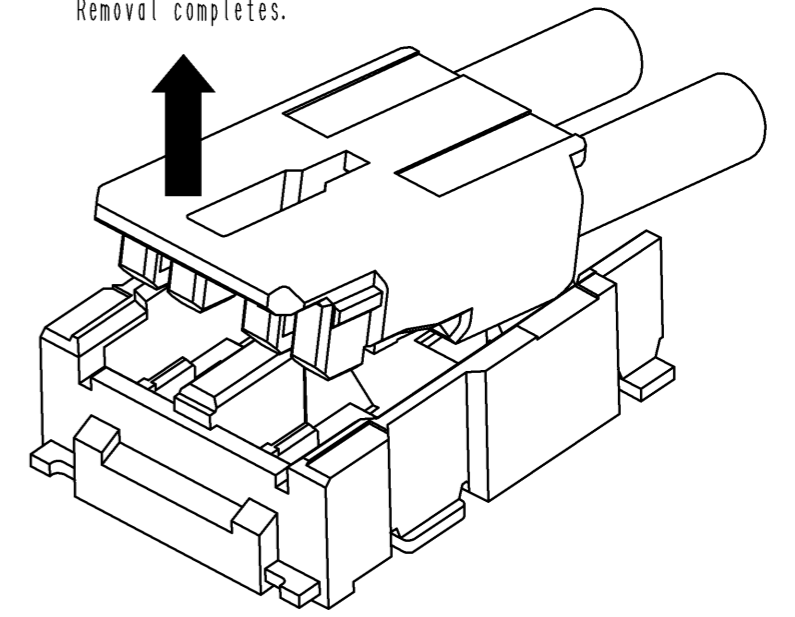
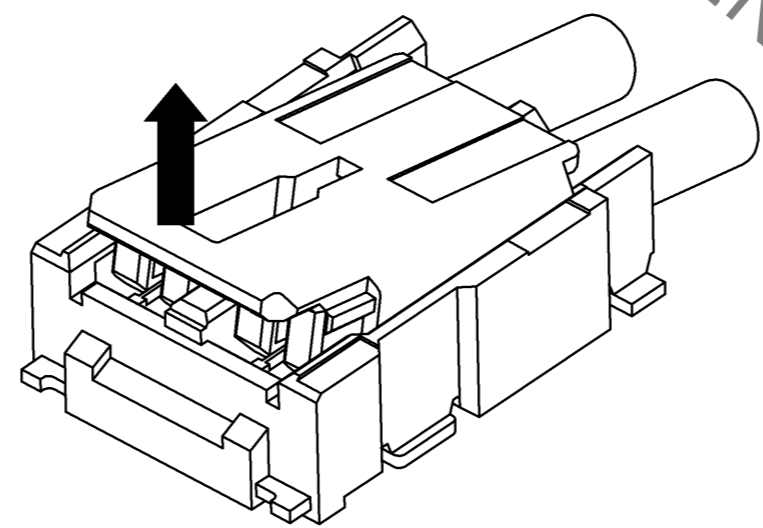
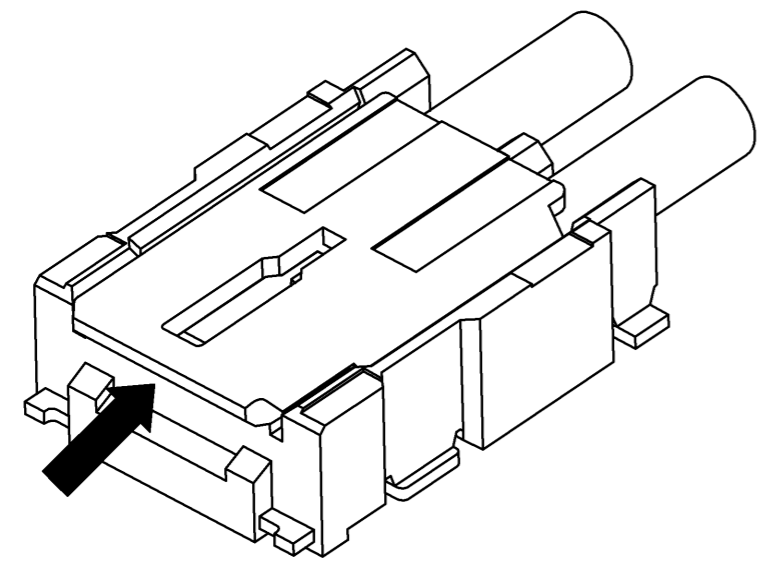

図番:	EDC3-336115-02
製品名:	DF61-2P-2.2V(22)
製品コード:	CL666-5001-1-22

Apr.1.2019 Copyright 2019 HIROSE ELECTRIC CO., LTD. All Rights Reserved. In case of consideration for using Automotive equipment / device which demand high reliability, kindly contact our sales window correspondents.