

4 PLACES
APPLIES TO ALL CIRCUIT SIZES
BOTH PEGGED AND FLANGED

CIRCUIT SIZE	DIM. "A"	DIM. "B"	DIM. "C"	DIM. "D"
2	.606 (15.40)	N.A.	.213 (5.40)	.354 (9.00)
4	.772 (19.60)	.165 (4.20)	.378 (9.60)	.520 (13.20)
6	.937 (23.80)	.331 (8.40)	.543 (13.80)	.685 (17.40)
8	1.102 (28.00)	.496 (12.60)	.709 (18.00)	.850 (21.60)
10	1.268 (32.20)	.661 (16.80)	.874 (22.20)	1.016 (25.80)
12	1.433 (36.40)	.827 (21.00)	1.039 (26.40)	1.181 (30.00)
14	1.598 (40.60)	.992 (25.20)	1.205 (30.60)	1.346 (34.20)
16	1.764 (44.80)	1.157 (29.40)	1.370 (34.80)	1.512 (38.40)
18	1.929 (49.00)	1.323 (33.60)	1.535 (39.00)	1.677 (42.60)
20	2.094 (53.20)	1.488 (37.80)	1.701 (43.20)	1.843 (46.80)
22	2.260 (57.40)	1.654 (42.00)	1.866 (47.40)	2.008 (51.00)
24	2.425 (61.60)	1.819 (46.20)	2.031 (51.60)	2.173 (55.20)

- NOTES:**
- MATERIALS:**
HOUSING MATERIAL OPTIONS: SEE CHART FOR SPECIFIC PART
 NYLON, UNFILLED, UL94V-2, COLOR: NATURAL
 NYLON, UNFILLED, UL94V-2, COLOR: BLACK
 NYLON, UNFILLED, UL94V-0, COLOR: NATURAL
 NYLON, UNFILLED, UL94V-0, COLOR: BLACK
 TERMINALS: BRASS
 - FINISH (PLATING) OPTIONS:** SEE CHART FOR SPECIFIC PART
 "GS" = 0.00076/(.000030) MIN. SELECT GOLD AND
 0.00254/(.0000100) SELECT MATTE TIN OVER
 0.00127/(.000050) MIN. NICKEL
 "MS" = 0.00254/(.000100) MIN. MATTE TIN OVER
 0.00127/(.000050) MIN. NICKEL
 - PRODUCT SPECIFICATION:** PS-5556-001
 - PACKAGING:** SEE CHART: BULK PER PK-5569-002
 TRAY PER PK-5569-003
 - CIRCUITS SHOWN PROVIDE THE MAKE-FIRST/BREAK-LAST FEATURE.**
 SEE CHARTS ON SHEETS 3 & 4 FOR SPECIFIC CIRCUIT LOCATIONS.
 - PART MATES WITH MINI-FIT JR. RECEPTACLE #5557.
 - CONNECTORS ARE NOT TO BE MATED OR UNMATED WHILE CIRCUITS ARE LIVE.
 - PARTS ARE NOT DESIGNED FOR CURRENT SHARING.
 - DISCOLORATION IN THE BANDOLIER CARRIER AREA OF THE PIN IS INHERENT TO THE PLATING PROCESS AND IS DUE TO THE MASKING EFFECT OF THE CARRIER. THIS DISCOLORATION, IF PRESENT, IS IN A NON-FUNCTIONAL AREA OF THE PIN AND WILL NOT EFFECT THE PERFORMANCE OF THE HEADER ASSEMBLY.
 - PART CONFORMS TO CLASS "B" REQUIREMENTS OF COSMETIC SPECIFICATION PS-45499-002.
 - FORMING MARKS ARE ACCEPTABLE.
 - CORNER CORE-OUTS ARE OPTIONAL AND MAY OR MAY NOT BE PRESENT.
 - TEXT ON PART IS FOR REFERENCE ONLY. TEXT AND TEXT LOCATION MAY VARY DEPENDING ON PART NUMBER AND/OR TOOL.

THIS DRAWING CONTAINS INFORMATION THAT IS PROPRIETARY TO MOLEX ELECTRONIC TECHNOLOGIES, LLC AND SHOULD NOT BE USED WITHOUT WRITTEN PERMISSION

QUALITY SYMBOLS	2017/07/07 2017/07/11 2017/07/18 UPDATE NOTE 1 EC NO: 119136 DRWN: BAPPELDORN CHKD: JBELL APPR: FSMITH	GENERAL TOLERANCES (UNLESS SPECIFIED)		DIMENSION UNITS	SCALE	
		MM	INCH	MM/IN	4:1	
▽ = 0	DRWN BY: POLGAR DATE: 1998/01/23 CHK'D BY: BANDURA DATE: 1998/01/28 APPR BY: FSMITH DATE: 2011/05/18	4 PLACES	±	±	MINI-FIT JR RIGHT ANGLE HEADER ASSY CUSTOM HEADERS PRODUCT CUSTOMER DRAWING	
▽ = 0		3 PLACES	±	± 0.015		
▽ = 0		2 PLACES	± 0.38	± 0.015		
▼ = 0		1 PLACES	± 0.38	±		
▽ = 0		0 PLACES	±	±		
⊠ = 0	ANGULAR TOL = 0.5	DRAFT WHERE APPLICABLE MUST REMAIN WITHIN DIMENSIONS		DRAWING SIZE	THIRD ANGLE PROJECTION	SERIES: 44130 MATERIAL NUMBER: SEE CHART CUSTOMER: GENERAL MARKET
■ = 0				C		DOCUMENT NUMBER: SD-44130-001 DOC TYPE: PSD DOC PART: 000 SHEET NUMBER: 1 OF 4
▽ = 0						

HOUSING WITH PEGS

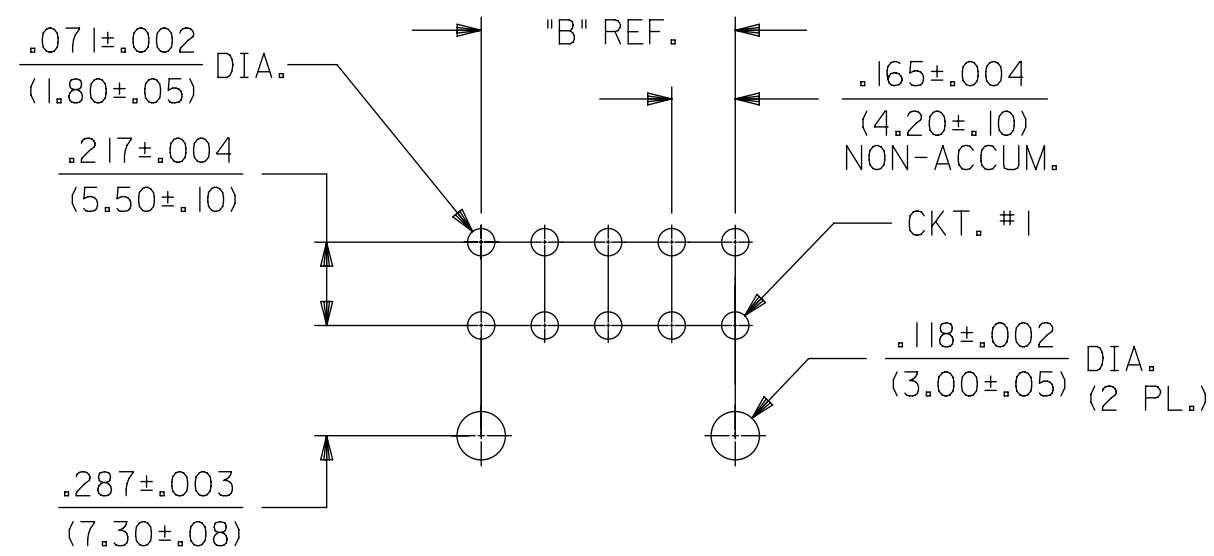
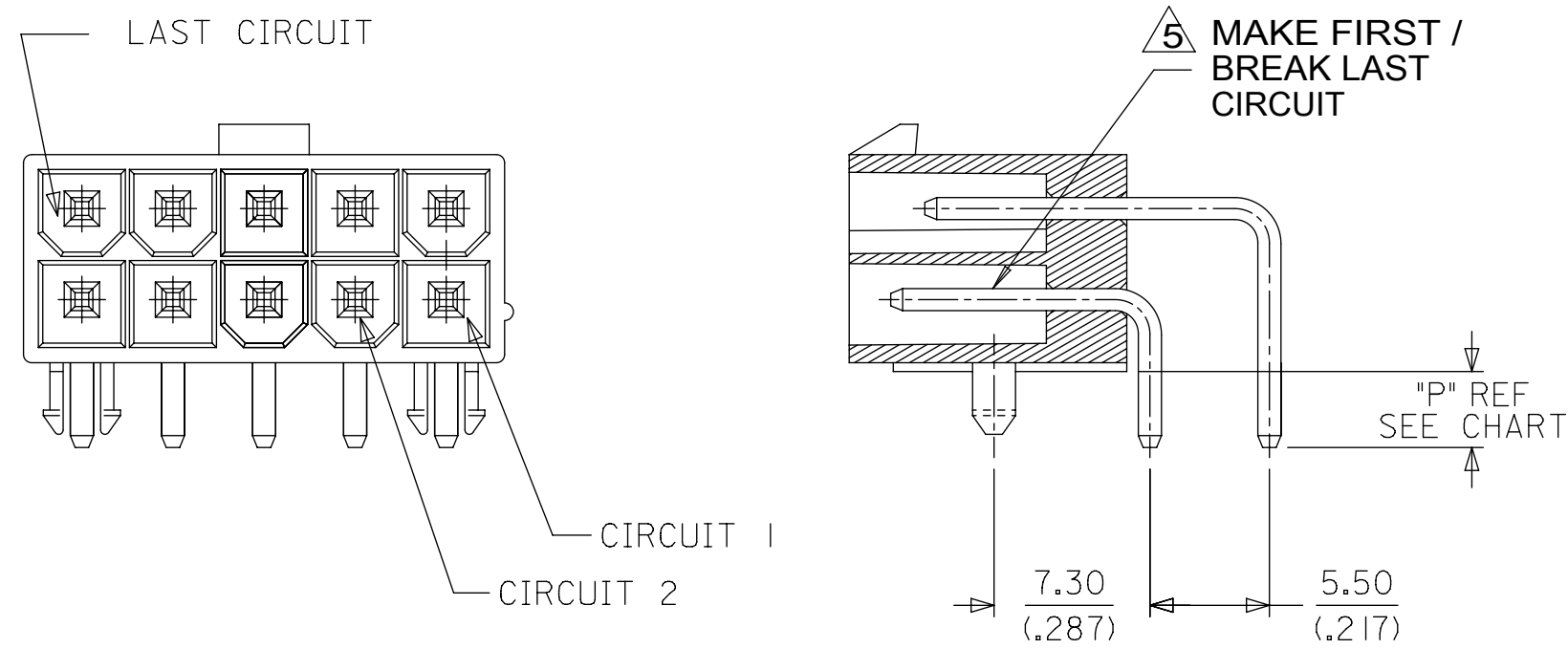

RECOMMENDED HOLE LAYOUT FOR
.070/(1.78) MAX. THICK P.C. BOARD.
(PEG MOUNT)

HOUSING WITH FLANGE

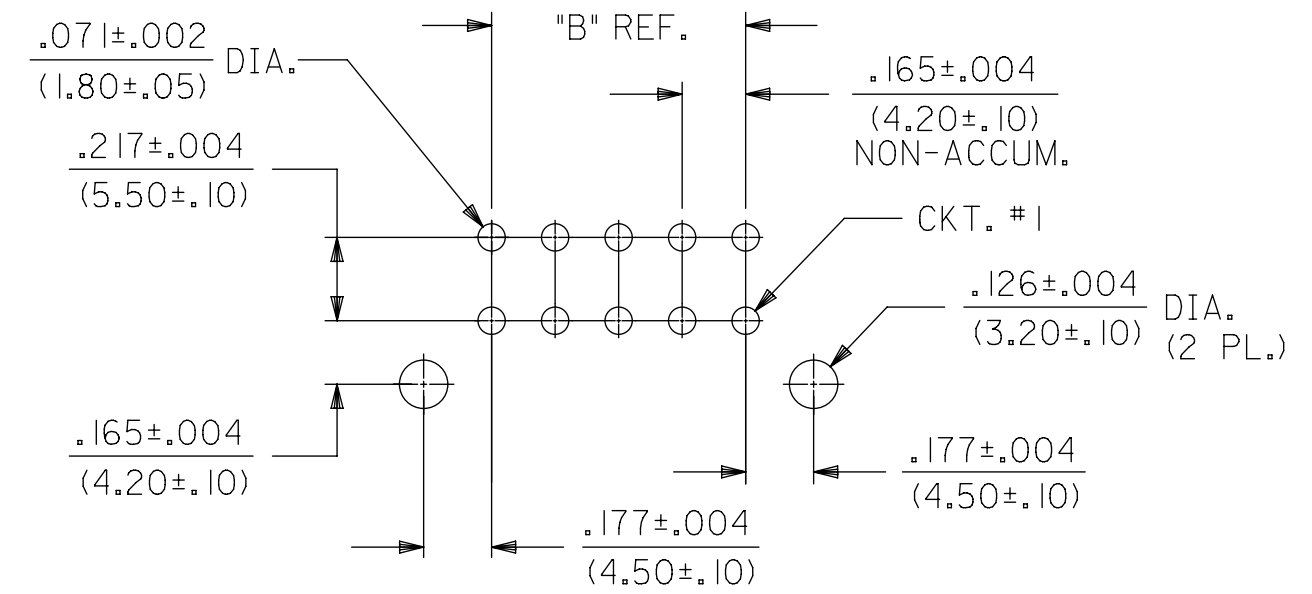
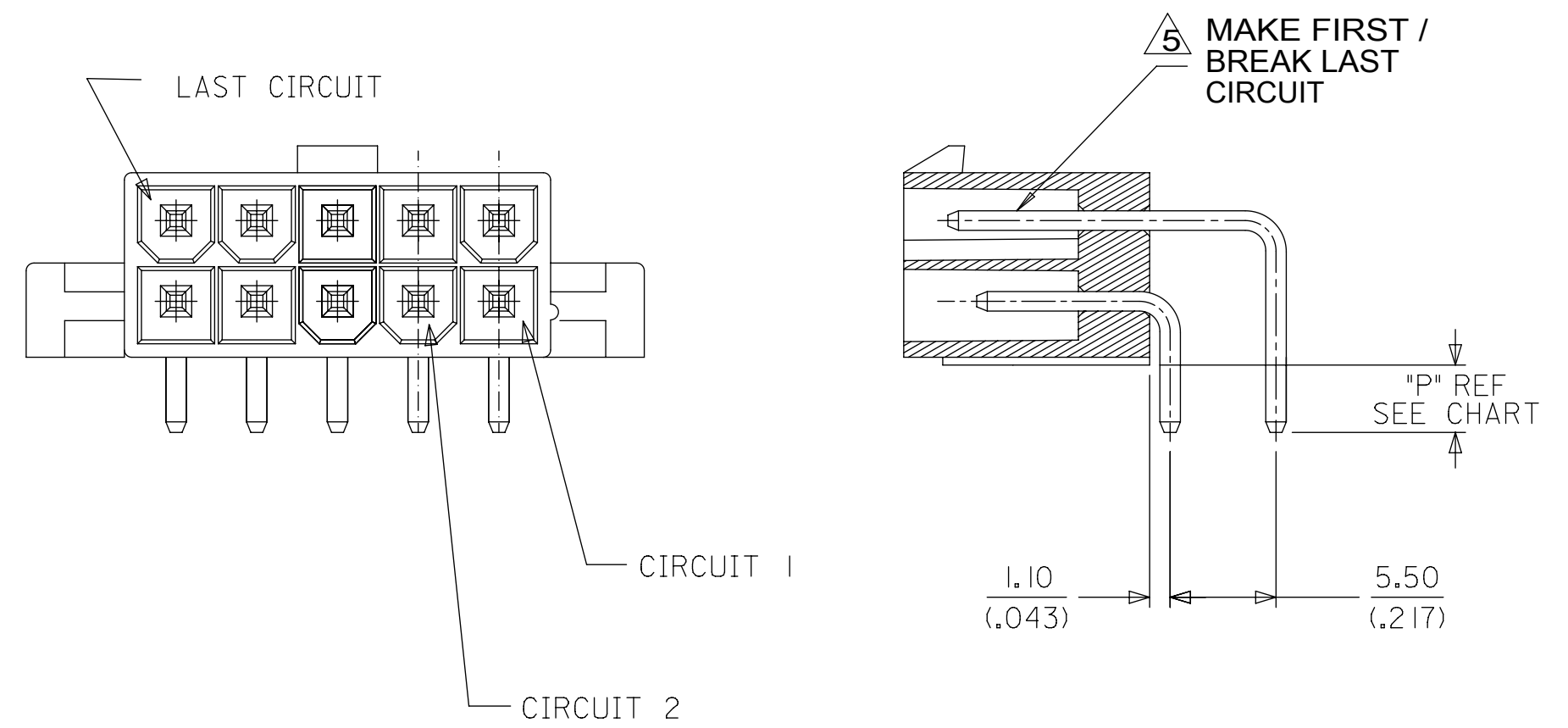

RECOMMENDED HOLE LAYOUT FOR
.070/(1.78) MAX. THICK P.C. BOARD.
(FLANGE MOUNT)

QUALITY SYMBOLS ▽ = 0 ▽ = 0 ▽ = 0 ▼ = 0 ▽ = 0 ⊠ = 0 ■ = 0 ▽ = 0		THIS DRAWING CONTAINS INFORMATION THAT IS PROPRIETARY TO MOLEX ELECTRONIC TECHNOLOGIES, LLC AND SHOULD NOT BE USED WITHOUT WRITTEN PERMISSION		DIMENSION UNITS SCALE MM/IN 4:1							
GENERAL TOLERANCES (UNLESS SPECIFIED)		DRWN BY POLGAR DATE 1998/01/23		DRWN BY POLGAR DATE 1998/01/23				MINI-FIT JR RIGHT ANGLE HEADER ASSY CUSTOM HEADERS			
UPDATE NOTE 1 EC NO: 119136 DRWN: BAPPELDORN CHKD: JBELL REV APPR: FSMITH		2017/07/07 2017/07/11 2017/07/18		4 PLACES ± ± 3 PLACES ± ± 0.015 2 PLACES ± 0.38 ± 0.015 1 PLACES ± 0.38 ± 0 PLACES ± ±		APPR BY FSMITH DATE 2011/05/18		PRODUCT CUSTOMER DRAWING			
ANGULAR TOL = 0.5 DRAFT WHERE APPLICABLE MUST REMAIN WITHIN DIMENSIONS		DRAWING SIZE C		THIRD ANGLE PROJECTION		SERIES 44130		MATERIAL NUMBER SEE CHART		CUSTOMER GENERAL MARKET	
E10		DOCUMENT NUMBER SD-44130-001		DOC TYPE PSD		DOC PART 000		SHEET NUMBER 2 OF 4			

MATERIAL NUMBER	HOUSING MAT'L/COLOR	NO OF CKT	HOUSING OPTION	PKG	FINISH SEE NOTE #2	PIN IDENTIFICATION CODE / CIRCUIT LOCATION (SEE CHART BELOW) V = VOID																							
						CKT 1	CKT 2	CKT 3	CKT 4	CKT 5	CKT 6	CKT 7	CKT 8	CKT 9	CKT 10	CKT 11	CKT 12	CKT 13	CKT 14	CKT 15	CKT 16	CKT 17	CKT 18	CKT 19	CKT 20	CKT 21	CKT 22	CKT 23	CKT 24
44130-0001	NYLON 94V-2/BLACK	06	PEG	TRAY	MS					2																			
44130-0002	NYLON 94V-2/BLACK	08	PEG	TRAY	MS	2																							
44130-0003	NYLON 94V-0/BLACK	08	PEG	TRAY	MS	2																							
44130-0004	NYLON 94V-0/BLACK	06	PEG	TRAY	MS					2																			
44130-0005	NYLON 94V-0/NATURAL	04	PEG	BULK	MS	2	3	2	2																				
44130-0006	NYLON 94V-0/NATURAL	06	PEG	BULK	MS	2			2	2	2																		
44130-0007	NYLON 94V-0/NATURAL	10	FLANGES	BULK	MS	4	4	4	4	4	4	4	4	4															
44130-0008	NYLON 94V-0/NATURAL	06	PEG	TRAY	MS	V			2	2	2																		
44130-0009	NYLON 94V-2/NATURAL	06	FLANGES	TRAY	MS	2	2	2		2	2																		
44130-0013	NYLON 94V-2/NATURAL	24	PEG	TRAY	MS	2	2																		2				
44130-0015	NYLON 94V-0/BLACK	08	PEG	TRAY	MS		2																						
44130-0017	NYLON 94V-0/NATURAL	02	PEG	BULK	MS	2	1																						
44130-0024	NYLON 94V-0/NATURAL	08	PEG	BULK	GS	2	2	5	2	2	5	2	2																
44130-0026	NYLON 94V-2/NATURAL	04	PEG	BULK	MS	8	8	8	8																				
44130-0027	NYLON 94V-0/NATURAL	02	PEG	BULK	MS	5	5																						
44130-0028	NYLON 94V-0/NATURAL	04	PEG	BULK	MS	8	8	8	8																				
44130-0030	NYLON 94V-0/NATURAL	06	PEG	TRAY	GS	2	1	2	2	2	2																		
44130-0031	NYLON 94V-0/NATURAL	08	PEG	BULK	MS	9	9	9	9	9	9	9																	

PIN ID	MATING CONFIGURATION	DIM P REF (PCB TAIL LENGTH)
1	MAKE FIRST/BREAK LAST (LONGER PIN)	3.5 (.14)
2	STANDARD MATING	3.5 (.14)
3	MAKE FIRST/BREAK LAST (LONGER PIN)	4.9 (.19)
4	STANDARD MATING	6.0 (.24)
5	MAKE FIRST/BREAK LAST (LONGER PIN)	4.2 (.17)
6	STANDARD MATING	4.2 (.17)
8	STANDARD MATING	5.3 (.21)

PIN ID	MATING CONFIGURATION	DIM P (PCB TAIL LENGTH)
9	STANDARD MATING	8.0 (.31)

THIS DRAWING CONTAINS INFORMATION THAT IS PROPRIETARY TO MOLEX ELECTRONIC TECHNOLOGIES, LLC AND SHOULD NOT BE USED WITHOUT WRITTEN PERMISSION

QUALITY SYMBOLS 	UPDATE NOTE 1 EC NO: 119136 DRWN: BAPPELDORN CHKD: JBELL REV APPR: FSMITH	GENERAL TOLERANCES (UNLESS SPECIFIED)		DIMENSION UNITS MM/IN	SCALE 1:1	
		4 PLACES ± ± 3 PLACES ± ± 0.015 2 PLACES ± 0.38 ± 0.015 1 PLACES ± 0.38 ± 0 PLACES ± ±		DRWN BY POLGAR	DATE 1998/01/23	
		ANGULAR TOL = 0.5		CHK'D BY BANDURA	DATE 1998/01/28	
		DRAFT WHERE APPLICABLE MUST REMAIN WITHIN DIMENSIONS		APPR BY FSMITH	DATE 2011/05/18	
E10		DRAWING SIZE C	THIRD ANGLE PROJECTION 	PRODUCT CUSTOMER DRAWING		SERIES 44130
RELEASE STATUS P1		RELEASE DATE 18.07.2017 20:03:33		MATERIAL NUMBER SEE CHART		CUSTOMER GENERAL MARKET
DOCUMENT NUMBER SD-44130-001		DOC TYPE PSD	DOC PART 000	SHEET NUMBER 3 OF 4		

MATERIAL NUMBER	HOUSING MAT'L/COLOR	NO OF CKT	HOUSING OPTION	PKG	FINISH SEE NOTE #2	PIN IDENTIFICATION CODE / CIRCUIT LOCATION (SEE CHART BELOW)																								V = VOID			
						CKT 1	CKT 2	CKT 3	CKT 4	CKT 5	CKT 6	CKT 7	CKT 8	CKT 9	CKT 10	CKT 11	CKT 12	CKT 13	CKT 14	CKT 15	CKT 16	CKT 17	CKT 18	CKT 19	CKT 20	CKT 21	CKT 22	CKT 23	CKT 24				
44130-0032	NYLON 94V-0/NATURAL	16	PEG	TRAY	MS	8	8	8	8	8	8	8	8	8	8	8	8	8	8	8	8												
44130-0036	NYLON 94V-2/NATURAL	06	PEG	TRAY	MS	2	1	2	2	1	2																						
44130-0037	NYLON 94V-0/NATURAL	06	PEG	TRAY	MS	2	V	2	2	V	2																						
44130-0038	NYLON 94V-2/NATURAL	10	PEG	TRAY	MS	2	V	2	V	2	2	V	2	V	2																		
44130-0039	NYLON 94V-0/NATURAL	04	PEG	TRAY	MS	1	2	2	2																								
44130-0040	NYLON 94V-0/NATURAL	04	PEG	TRAY	MS	2	1	2	2																								
44130-0041	NYLON 94V-0/NATURAL	06	PEG	TRAY	GS	2	V	1	2	V	2																						

PIN ID	MATING CONFIGURATION	DIM PREF (PCB TAIL LENGTH)
1	MAKE FIRST/BREAK LAST (LONGER PIN)	3.5 (.14)
2	STANDARD MATING	3.5 (.14)
3	MAKE FIRST/BREAK LAST (LONGER PIN)	4.9 (.19)
4	STANDARD MATING	6.0 (.24)
5	MAKE FIRST/BREAK LAST (LONGER PIN)	4.2 (.17)
6	STANDARD MATING	4.2 (.17)
8	STANDARD MATING	5.3 (.21)

THIS DRAWING CONTAINS INFORMATION THAT IS PROPRIETARY TO MOLEX ELECTRONIC TECHNOLOGIES, LLC AND SHOULD NOT BE USED WITHOUT WRITTEN PERMISSION

QUALITY SYMBOLS 	UPDATE NOTE 1 EC NO: 119136 DRWN: BAPPELDORN CHKD: JBELL REV APPR: FSMITH 2017/07/07 2017/07/11 2017/07/18	GENERAL TOLERANCES (UNLESS SPECIFIED)		DIMENSION UNITS		SCALE	
		MM INCH		MM/IN		1:1	
		4 PLACES ± ±		POLGAR		DATE 1998/01/23	
		3 PLACES ± ± 0.015		CHK'D BY BANDURA		DATE 1998/01/28	
2 PLACES ± 0.38 ± 0.015		APPR BY FSMITH		DATE 2011/05/18			
1 PLACES ± 0.38 ±		DRAWING SIZE		THIRD ANGLE PROJECTION			
0 PLACES ± ±		ANGULAR TOL = 0.5		C			
DRAFT WHERE APPLICABLE MUST REMAIN WITHIN DIMENSIONS							

**MINI-FIT JR
RIGHT ANGLE HEADER ASSY CUSTOM HEADERS**

PRODUCT CUSTOMER DRAWING

SERIES	MATERIAL NUMBER	CUSTOMER
44130	SEE CHART	GENERAL MARKET

DOCUMENT NUMBER	DOC TYPE	DOC PART	SHEET NUMBER
SD-44130-001	PSD	000	4 OF 4

Mouser Electronics

Authorized Distributor

Click to View Pricing, Inventory, Delivery & Lifecycle Information:

[Molex:](#)

[44130-0018](#)