

- GENERAL NOTES: (UNLESS OTHERWISE SPECIFIED)
- MATING TERMINAL SHOWN ON SD-33012-002
 - MATERIAL: ASTM B422, UNS C19025, HR04
THICKNESS: 0.30 mm +0.01
TEMPER: FULL HARD (REF)
TENSILE: 496-572 MPA
 - TIN PLATED TERMINAL FINISH:
OVERALL UNDERPLATE ELECTRODEPOSITED NICKEL
OVERALL ELECTRODEPOSITED REFLOW TIN
 - GOLD PLATED TERMINAL FINISH:
OVERALL UNDERPLATE ELECTRODEPOSITED DUCTILE SULFAMATE NICKEL
CONTACT AREA - ELECTRODEPOSITED GOLD
GRIP AREA - ELECTRODEPOSITED 100% TIN MATTE FINISH
 - SILVER PLATED TERMINAL FINISH:
OVERALL UNDERPLATE ELECTRODEPOSITED DUCTILE SULFAMATE NICKEL
CONTACT AREA - ELECTRODEPOSITED PURE SILVER (0.5% MAX IMPURITIES) SEMI-BRIGHT FINISH
- SILVER ANTI-TARNISH - EVABRITE
GRIP AREA - ELECTRODEPOSITED 100% TIN MATTE FINISH
 - MEETS CRIMP PERFORMANCE SPECIFICATION SAE/USCAR-21 (8/2001)
 - MEETS PERFORMANCE STANDARD FOR AUTOMOTIVE ELECTRICAL CONNECTOR SYSTEMS SAE/USCAR-2 REV 3 (APRIL 2001)
 - MEETS FIELD CORRELATED LIFE TEST SAE/USCAR-20 (11/2001)
 - MEETS WIRING COMPONENT DESIGN GUIDELINES SAE/USCAR-12 REV 2 (12/2001)
 - MEETS ELECTRICAL CONNECTION SYSTEM DESIGN SPECIFICATION (SDS) REV 11 (5/2002)
 - REFERENCE PK-31300-516 FOR REEL DIRECTION
 - REFERENCE AS-33000-001 FOR CRIMP INFORMATION

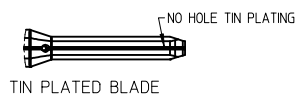
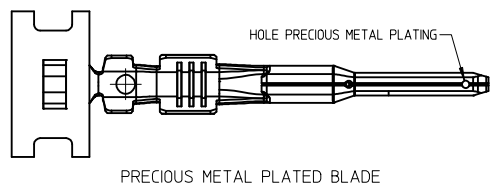

ENTER DESCRIPTION EC NO: UAU2017-1076 DRWINWENKATESHSH2017/05/24 CHKD:A. DHIR 2017/05/29 APPR:TJSMITH 2017/06/09	QUALITY SYMBOLS ▽=0 ▽=0 ▽=0	GENERAL TOLERANCES (UNLESS SPECIFIED)		DIMENSION STYLE MM ONLY		SCALE 4:1	DESIGN UNITS METRIC	THIRD ANGLE PROJECTION	
		mm	INCH	DRAWN BY L.PULLIAM	DATE 2006/01/31	TITLE MX150 15MM BLADE TERMINAL			
D1	DESCRIPTION	4 PLACES	±	---	±	---	CHECKED BY A.DHIR		DATE 2006/02/01
		3 PLACES	±	---	±	---	APPROVED BY B.MOSER		DATE 2006/02/02
		2 PLACES	±	0.10	±	---	MATERIAL NO. SEE TABLE		
		1 PLACE	±	0.3	±	---	DOCUMENT NO. SD-33000-001		SHEET NO. 1 OF 5
		0 PLACE	±		±		THIS DRAWING CONTAINS INFORMATION THAT IS PROPRIETARY TO MOLEX INCORPORATED AND SHOULD NOT BE USED WITHOUT WRITTEN PERMISSION		
		ANGULAR ± 3 °							
DRAFT WHERE APPLICABLE MUST REMAIN WITHIN DIMENSIONS		SIZE C							

FAMILY	GENDER	SEALING	PLATING	PART NUMBER	PAYOFF DIRECTION	GRIP CODE	WIRE SIZES*	A ±0.30	B ±0.30	C ±0.30	D ±0.30	SPECIAL CHARACTERISTICS
MX150	BLADE	MAT SEAL UNSEALED	Sn	33000-0001	RIGHT (B)	14	14AWG	3.9	3.8	1.7	1.6	HIGH PERFORMANCE Sn
				33000-1001	LEFT (D)		1.50-2.00mm ²					
				33000-0002	RIGHT (B)	18	20/18/16AWG	3.3	3.1	1.3	1.4	
				33000-1002	LEFT (D)		0.75-1.00mm ²					
				33000-0003	RIGHT (B)	22	22AWG	2.5	2.6	0.9	1.0	
				33000-1003	LEFT (D)							
				33000-0004	RIGHT (B)	M3	0.35-0.50mm ²	2.5	2.7	0.9	1.54 ±0.1	
			33000-1004	LEFT (D)								
			Au	33011-1002	RIGHT (B)	14	14AWG	3.9	3.8	1.7	1.6	HIGH PERFORMANCE Au
				33011-0002	LEFT (D)		1.50-2.00mm ²					
				33011-1004	RIGHT (B)	18	20/18/16AWG	3.3	3.1	1.3	1.4	
				33011-0004	LEFT (D)		0.75-1.00mm ²					
				33011-1006	RIGHT (B)	22	22AWG	2.5	2.6	0.9	1.0	
				33011-0006	LEFT (D)							
				33011-1008	RIGHT (B)	M3	0.35-0.50mm ²	2.5	2.7	0.9	1.54 ±0.1	
			33011-0008	LEFT (D)								
			Ag	33011-2003	RIGHT (B)	14	14AWG	3.9	3.8	1.7	1.6	HIGH PERFORMANCE Ag
				33011-3003	LEFT (D)		1.50-2.00mm ²					
				33011-2002	RIGHT (B)	18	20/18/16AWG	3.3	3.1	1.3	1.4	
				33011-3002	LEFT (D)		0.75-1.00mm ²					
				33011-2001	RIGHT (B)	22	22AWG	2.5	2.6	0.9	1.0	
33011-3001	LEFT (D)											
33011-2004	RIGHT (B)	M3		0.35-0.50mm ²	2.5	2.7	0.9	1.54 ±0.1				
33011-3004	LEFT (D)											

* REFERENCE AS-33000-001 FOR SPECIFIC WIRE TYPES

ENTER DESCRIPTION EC NO: UAU2017-1076 DRW: NANKATESH/2017/05/24 CHK: D.A. DHIR 2017/05/29 APPR: T.JSM/TH 2017/06/09	QUALITY SYMBOLS ▽=0 ▽=0 ▽=0	GENERAL TOLERANCES (UNLESS SPECIFIED)		DIMENSION STYLE MM ONLY		SCALE	DESIGN UNITS METRIC	THIRD ANGLE PROJECTION			
		4 PLACES ± --- ± ---	mm INCH	DRAWN BY L.PULLIAM	DATE 2006/01/31	TITLE MX150 15MM BLADE TERMINAL					
		3 PLACES ± --- ± ---		CHECKED BY A.DHIR	DATE 2006/02/01	molex					
		2 PLACES ± 0.10 ± ---		APPROVED BY B.MOSER	DATE 2006/02/02	MATERIAL NO. SEE TABLE		DOCUMENT NO. SD-33000-001			SHEET NO. 2 OF 5
		1 PLACE ± 0.3 ± ---		DRAFT WHERE APPLICABLE MUST REMAIN WITHIN DIMENSIONS		THIS DRAWING CONTAINS INFORMATION THAT IS PROPRIETARY TO MOLEX INCORPORATED AND SHOULD NOT BE USED WITHOUT WRITTEN PERMISSION					
0 PLACE ± ±		ANGULAR ± 3 °									

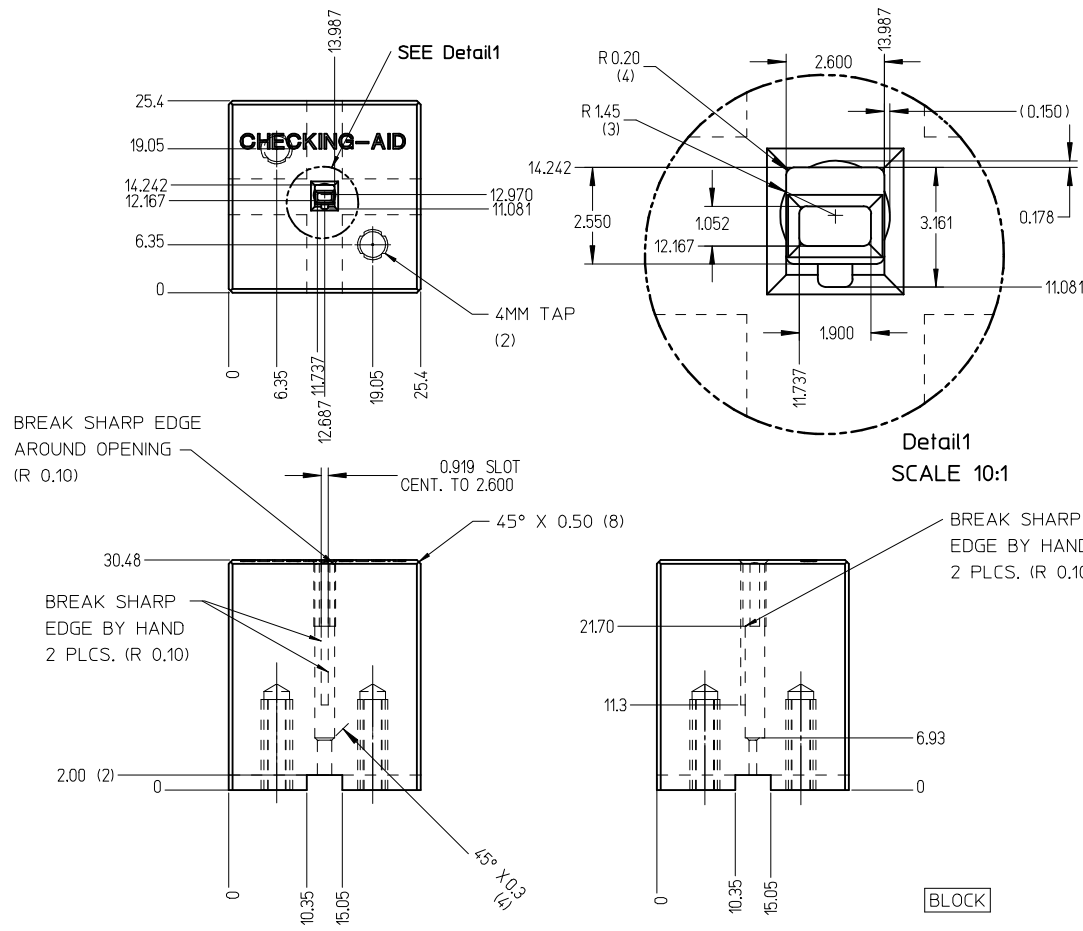

CHECKING-AID
 2 PIECE ASM. A2 TOOL STEEL
 HARDEN & GRIND TO A ROCKWELL
 HARDNESS "C" SCALE OF 56-58

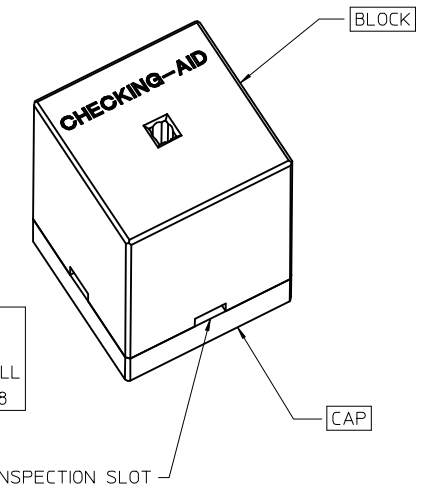

CHECKING AID TOLERANCE
 .XXX = .005
 .XX = .03
 .X = .3

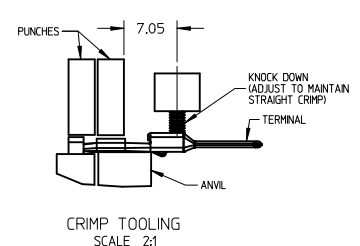
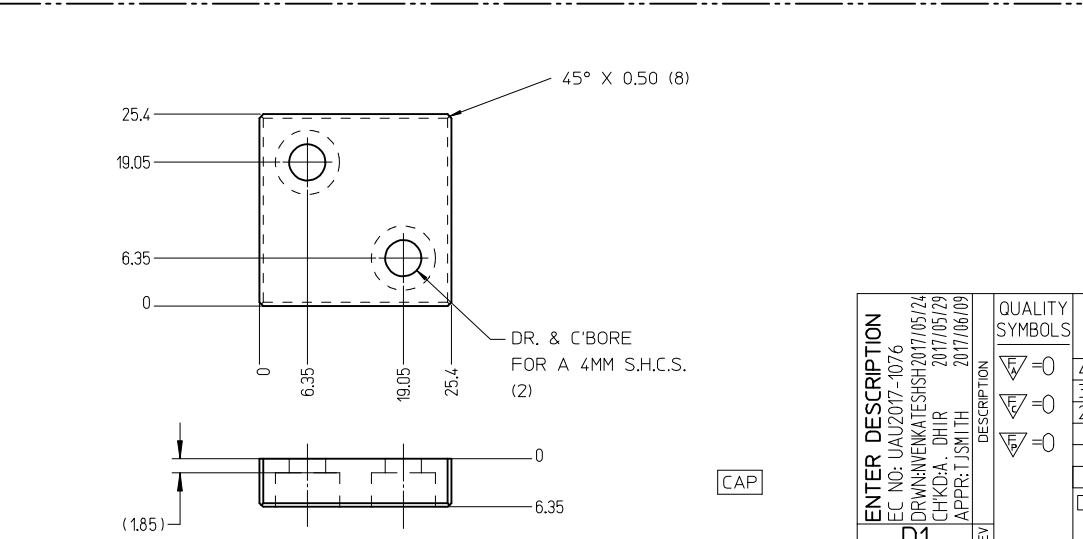

- CRIMP REQUIREMENTS:
1. CRIMP STRAIGHTNESS MUST BE MAINTAINED. USE A KNOCKDOWN TOOL LOCATED AS SHOWN. TERMINAL BOX MUST NOT BE DEFORMED
 2. AFTER CRIMPING, THE TERMINAL AND WIRE MUST FIT FREELY INTO THE CHECKING AID 33000-700. PROPER INSERTION DEPTH IS MET WHEN BLADE TIP STOPS ON CAP. SLOTS PROVIDED TO VISUALLY INSPECT STOPPAGE OF PIN TIP.
 3. FOR OTHER MECHANICAL REQUIREMENTS ON CRIMPED TERMINALS, REFER TO SAE/USCAR-21 (5-13-02) SECTIONS 4.2 (VISUAL INSPECTION), 4.3 (CROSS SECTION ANALYSIS) AND 4.4 (CONDUCTOR CRIMP PULLOUT FORCE)

REV	DESCRIPTION	QUALITY SYMBOLS
D1	ENTER DESCRIPTION EC NO: UAU2017-1076 DRWN:VENKATESH2017/05/24 CHKD:A. DHIR 2017/05/29 APPR:TJSM:TH 2017/06/09	▽=0 ▽=0 ▽=0

GENERAL TOLERANCES (UNLESS SPECIFIED)	
	mm INCH
4 PLACES ±	±
3 PLACES ±	±
2 PLACES ±	±0.10
1 PLACE ±	±0.3
0 PLACE ±	±
ANGULAR ± 3 °	
DRAFT WHERE APPLICABLE MUST REMAIN WITHIN DIMENSIONS	

DIMENSION STYLE MM ONLY	
DRAWN BY	DATE
L. PULLIAM	2006/01/31
CHECKED BY	DATE
A. DHIR	2006/02/01
APPROVED BY	DATE
B. MOSER	2006/02/02
MATERIAL NO.	
SEE TABLE	
SIZE	C

SCALE	2:1	DESIGN UNITS	METRIC	THIRD ANGLE PROJECTION
MX150 1.5MM BLADE TERMINAL				
molex				SHEET NO.
DOCUMENT NO. SD-33000-001				3 OF 5

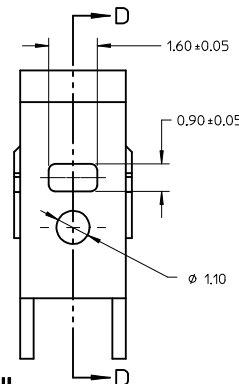
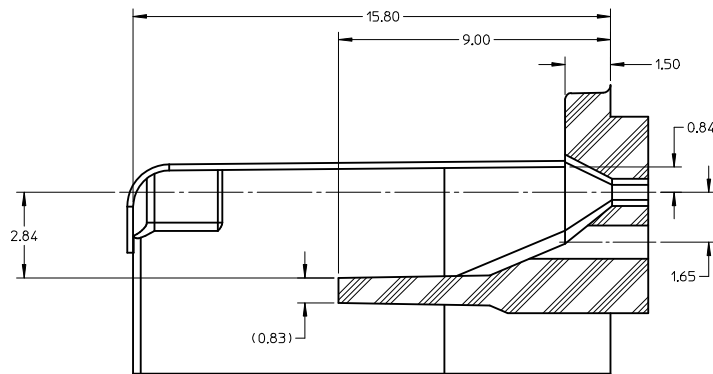
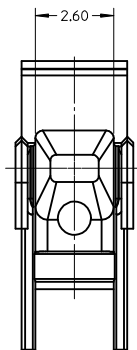

SECTION D-D

TPA/INSERT DETAIL

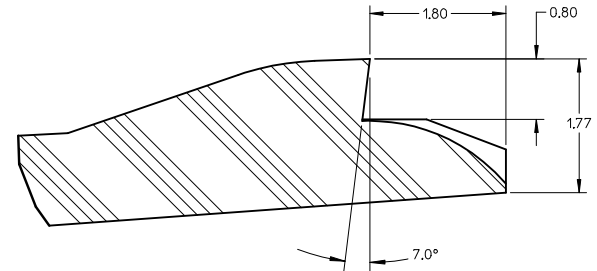
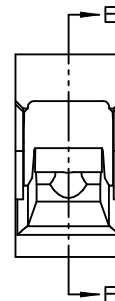
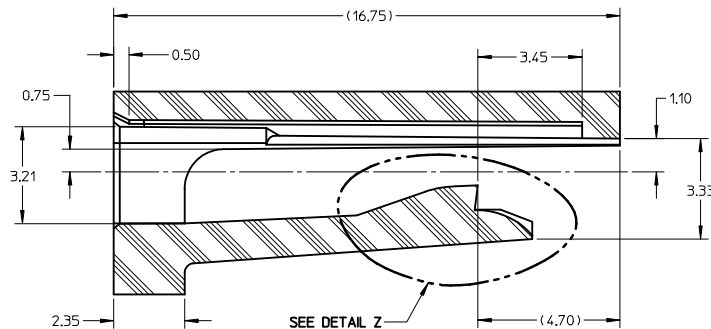
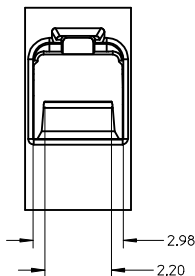

DETAIL Z
SCALE 20:1

NOTES: (UNLESS OTHERWISE SPECIFIED)

- TOLERANCES: LINEAR ± 0.10
ANGULAR 3°
- ALL DRAFT WITHIN TOLERANCE
- MAX RADI ON ALL CORNERS SHOWN SHARP: 0.10
- MAX FLASH PERMISSIBLE: 0.1
- EJECTOR PIN MARKS PERMISSIBLE IF FLUSH TO 0.25 BELOW SURFACE
- MATERIAL: HOUSING/FINGER SPECIFICATION ENGINEERED FOR MATERIAL WITH THE FOLLOWING PROPERTIES:
A. FLEXURAL MODULUS = 4,500 TO 9,400 MPa
PER ASTM TEST D790
B. ELONGATION AT YIELD = 2.3% OR BETTER
PER ASTM TEST D638 TYPE V
- CAVITY SPEC FOR USE ONLY WITH MOLEX BLADE TERMINAL PART NUMBERS (EXCEPT P/N'S FOR UNSEALED APPLICATIONS) SPECIFIED ELSEWHERE ON THIS DRAWING

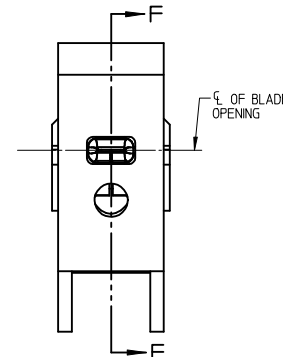
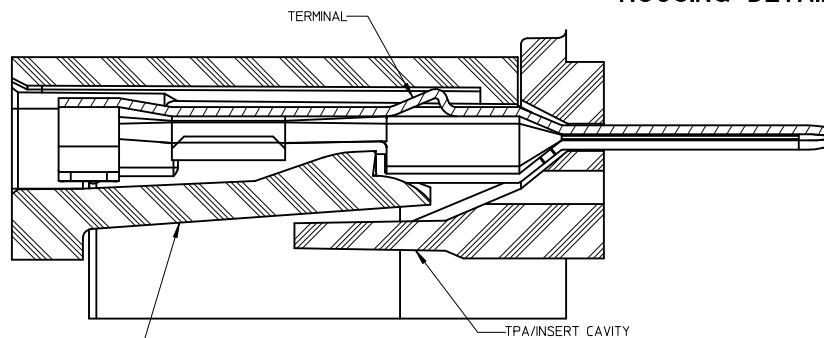
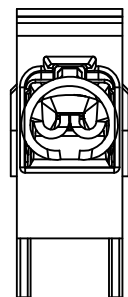

SECTION F-F

BLADE CAVITY ASSEMBLY VIEWS

ENTER DESCRIPTION EC NO: UAU2017-1076 DRWINVENKATESHSH2017/05/24 CHKD:A. DHIR 2017/05/29 APPR:TJSMITH 2017/06/09	QUALITY SYMBOLS ∇=0 ∇=0 ∇=0	GENERAL TOLERANCES (UNLESS SPECIFIED)		DIMENSION STYLE MM ONLY		SCALE METRIC	DESIGN UNITS METRIC	THIRD ANGLE PROJECTION	
		4 PLACES \pm --- \pm --- 3 PLACES \pm --- \pm --- 2 PLACES ± 0.10 \pm --- 1 PLACE ± 0.3 \pm --- 0 PLACE \pm \pm	mm INCH DRAWN BY DATE L.PULLIAM 2006/01/31 CHECKED BY DATE A.DHIR 2006/02/01 APPROVED BY DATE B.MOSER 2006/02/02	TITLE MX150 15MM BLADE TERMINAL		DOCUMENT NO. SD-33000-001		SHEET NO. 4 OF 5	
		ANGULAR $\pm 3^\circ$		MATERIAL NO. SEE TABLE		THIS DRAWING CONTAINS INFORMATION THAT IS PROPRIETARY TO MOLEX INCORPORATED AND SHOULD NOT BE USED WITHOUT WRITTEN PERMISSION			
		DRAFT WHERE APPLICABLE MUST REMAIN WITHIN DIMENSIONS		SIZE C					

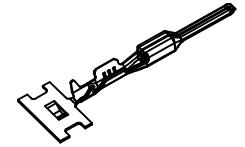

ISO VIEW
SCALE 2:1

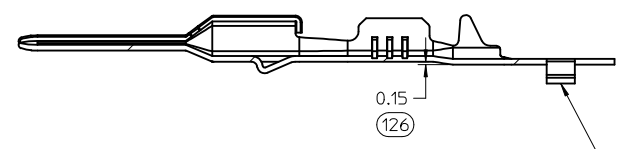
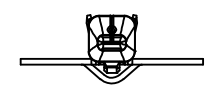
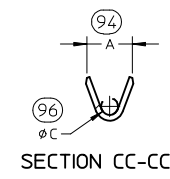
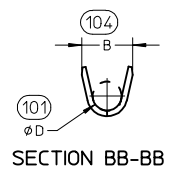
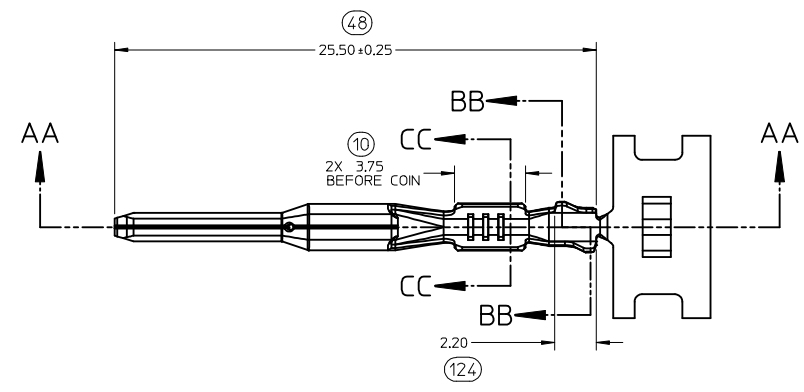

SECTION AA-AA
M3 GRIP CODE TERMINAL
SEE TABLE (SHEET 2) FOR PART NUMBERS

CARRIER BUMP DIRECTION
POINTS DOWN FOR TIN PLATED TERMINALS
POINTS UP FOR PRECIOUS METAL PLATED TERMINALS

ENTER DESCRIPTION EC NO: UAU2017-1076 DRWN:WENKATESHSH/2017/05/24 CHKD:A. DHIR 2017/05/29 APPR:T.JSMITH 2017/06/09	QUALITY SYMBOLS ▽=0 ▽=0 ▽=0	GENERAL TOLERANCES (UNLESS SPECIFIED)		DIMENSION STYLE MM ONLY	SCALE 5:1	DESIGN UNITS METRIC	THIRD ANGLE PROJECTION		
		4 PLACES ± --- ± --- 3 PLACES ± --- ± --- 2 PLACES ± 0.10 ± --- 1 PLACE ± 0.3 ± ---	mm INCH	DRAWN BY DATE L.PULLIAM 2006/01/31	CHECKED BY DATE A.DHIR 2006/02/01	TITLE MX150 15MM BLADE TERMINAL			
		ANGULAR ± 3°		APPROVED BY DATE B.MOSER 2006/02/02	MATERIAL NO. DOCUMENT NO. SEE TABLE SD-33000-001				
		DRAFT WHERE APPLICABLE MUST REMAIN WITHIN DIMENSIONS		SIZE C	THIS DRAWING CONTAINS INFORMATION THAT IS PROPRIETARY TO MOLEX INCORPORATED AND SHOULD NOT BE USED WITHOUT WRITTEN PERMISSION				
D1	REV					SHEET NO. 5 OF 5			

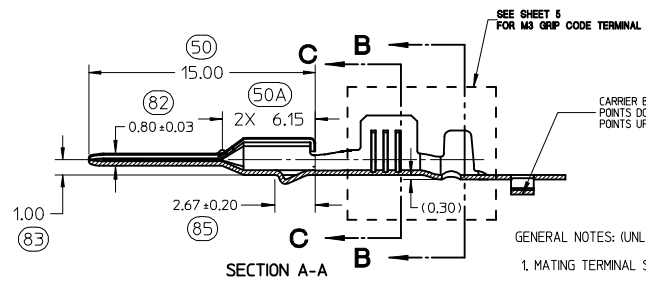
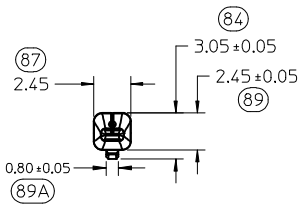
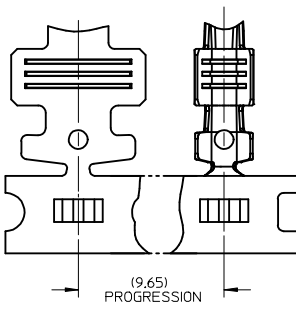
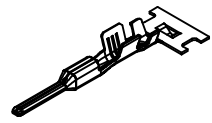
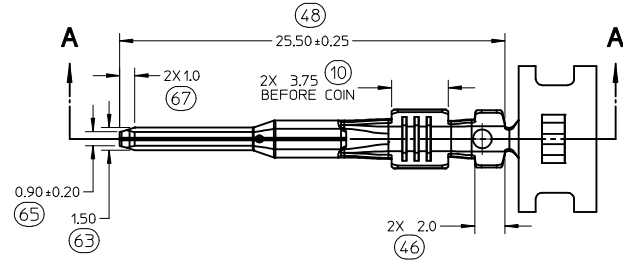
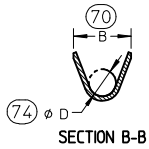
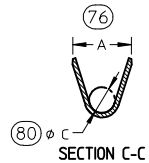

- GENERAL NOTES: (UNLESS OTHERWISE SPECIFIED)
- MATING TERMINAL SHOWN ON SD-33012-002
 - MATERIAL: ASTM B422, UNS C19025, HR04
THICKNESS: 0.30 mm +0.01
TEMPER: FULL HARD (REF)
TENSILE: 496-572 MPA
 - TIN PLATED TERMINAL FINISH:
OVERALL UNDERPLATE ELECTRODEPOSITED NICKEL
OVERALL ELECTRODEPOSITED REFLOW TIN
 - GOLD PLATED TERMINAL FINISH:
OVERALL UNDERPLATE ELECTRODEPOSITED DUCTILE SULFAMATE NICKEL
CONTACT AREA - ELECTRODEPOSITED GOLD
GRIP AREA - ELECTRODEPOSITED 100% TIN MATTE FINISH
 - SILVER PLATED TERMINAL FINISH:
OVERALL UNDERPLATE ELECTRODEPOSITED DUCTILE SULFAMATE NICKEL
CONTACT AREA - ELECTRODEPOSITED PURE SILVER (0.5% MAX IMPURITIES) SEMI-BRIGHT FINISH
- SILVER ANTI-TARNISH - EVABRITE
GRIP AREA - ELECTRODEPOSITED 100% TIN MATTE FINISH
 - MEETS CRIMP PERFORMANCE SPECIFICATION SAE/USCAR-21 (8/2001)
 - MEETS PERFORMANCE STANDARD FOR AUTOMOTIVE ELECTRICAL CONNECTOR SYSTEMS SAE/USCAR-2 REV 3 (APRIL 2001)
 - MEETS FIELD CORRELATED LIFE TEST SAE/USCAR-20 (11/2001)
 - MEETS WIRING COMPONENT DESIGN GUIDELINES SAE/USCAR-12 REV 2 (12/2001)
 - MEETS ELECTRICAL CONNECTION SYSTEM DESIGN SPECIFICATION (SDS) REV 11 (5/2002)
 - REFERENCE PK-31300-516 FOR REEL DIRECTION
 - REFERENCE AS-33000-001 FOR CRIMP INFORMATION

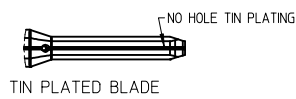
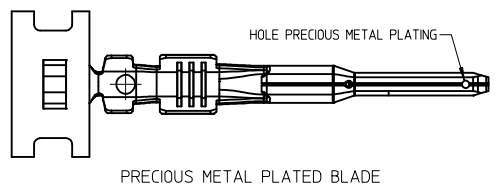

ENTER DESCRIPTION EC NO: UAU2017-1076 DRWINWENKATESHSH2017/05/24 CHKD:A. DHIR 2017/05/29 APPR:TJSMITH 2017/06/09	QUALITY SYMBOLS ▽=0 ▽=0 ▽=0	GENERAL TOLERANCES (UNLESS SPECIFIED)		DIMENSION STYLE MM ONLY		SCALE 4:1	DESIGN UNITS METRIC	THIRD ANGLE PROJECTION	
		mm	INCH	DRAWN BY L.PULLIAM	DATE 2006/01/31	TITLE MX150 15MM BLADE TERMINAL			
D1	REVISION	4 PLACES ±	---	±	---	CHECKED BY A.DHIR	DATE 2006/02/01	DOCUMENT NO. SD-33000-001	
		3 PLACES ±	---	±	---	APPROVED BY B.MOSER	DATE 2006/02/02		
DRAFT WHERE APPLICABLE MUST REMAIN WITHIN DIMENSIONS		ANGULAR ± 3 °		MATERIAL NO. SEE TABLE		THIS DRAWING CONTAINS INFORMATION THAT IS PROPRIETARY TO MOLEX INCORPORATED AND SHOULD NOT BE USED WITHOUT WRITTEN PERMISSION			

FAMILY	GENDER	SEALING	PLATING	PART NUMBER	PAYOFF DIRECTION	GRIP CODE	WIRE SIZES*	A ±0.30	B ±0.30	C ±0.30	D ±0.30	SPECIAL CHARACTERISTICS
MX150	BLADE	MAT SEAL UNSEALED	Sn	33000-0001	RIGHT (B)	14	14AWG	3.9	3.8	1.7	1.6	HIGH PERFORMANCE Sn
				33000-1001	LEFT (D)		1.50-2.00mm ²					
				33000-0002	RIGHT (B)	18	20/18/16AWG	3.3	3.1	1.3	1.4	
				33000-1002	LEFT (D)		0.75-1.00mm ²					
				33000-0003	RIGHT (B)	22	22AWG	2.5	2.6	0.9	1.0	
				33000-1003	LEFT (D)							
				33000-0004	RIGHT (B)	M3	0.35-0.50mm ²	2.5	2.7	0.9	1.54 ±0.1	
			33000-1004	LEFT (D)								
			Au	33011-1002	RIGHT (B)	14	14AWG	3.9	3.8	1.7	1.6	HIGH PERFORMANCE Au
				33011-0002	LEFT (D)		1.50-2.00mm ²					
				33011-1004	RIGHT (B)	18	20/18/16AWG	3.3	3.1	1.3	1.4	
				33011-0004	LEFT (D)		0.75-1.00mm ²					
				33011-1006	RIGHT (B)	22	22AWG	2.5	2.6	0.9	1.0	
				33011-0006	LEFT (D)							
				33011-1008	RIGHT (B)	M3	0.35-0.50mm ²	2.5	2.7	0.9	1.54 ±0.1	
			33011-0008	LEFT (D)								
			Ag	33011-2003	RIGHT (B)	14	14AWG	3.9	3.8	1.7	1.6	HIGH PERFORMANCE Ag
				33011-3003	LEFT (D)		1.50-2.00mm ²					
				33011-2002	RIGHT (B)	18	20/18/16AWG	3.3	3.1	1.3	1.4	
				33011-3002	LEFT (D)		0.75-1.00mm ²					
				33011-2001	RIGHT (B)	22	22AWG	2.5	2.6	0.9	1.0	
				33011-3001	LEFT (D)							
				33011-2004	RIGHT (B)	M3	0.35-0.50mm ²	2.5	2.7	0.9	1.54 ±0.1	
			33011-3004	LEFT (D)								

* REFERENCE AS-33000-001 FOR SPECIFIC WIRE TYPES

ENTER DESCRIPTION EC NO: UAU2017-1076 DRWINWENKATESHSH2017/05/24 CHKDA: DHIR 2017/05/29 APPR: T.JSM/TH 2017/06/09	QUALITY SYMBOLS ▽=0 ▽=0 ▽=0	GENERAL TOLERANCES (UNLESS SPECIFIED)		DIMENSION STYLE MM ONLY		SCALE	DESIGN UNITS METRIC	THIRD ANGLE PROJECTION			
		4 PLACES ± --- ± ---	3 PLACES ± --- ± ---	2 PLACES ± 0.10 ± ---	1 PLACE ± 0.3 ± ---	0 PLACE ± ±	DRAWN BY L.PULLIAM 2006/01/31	TITLE MX150 15MM BLADE TERMINAL			
		ANGULAR ± 3 °					CHECKED BY A.DHIR 2006/02/01	DOCUMENT NO. SD-33000-001			
		DRAFT WHERE APPLICABLE MUST REMAIN WITHIN DIMENSIONS					APPROVED BY B.MOSER 2006/02/02			THIS DRAWING CONTAINS INFORMATION THAT IS PROPRIETARY TO MOLEX INCORPORATED AND SHOULD NOT BE USED WITHOUT WRITTEN PERMISSION	

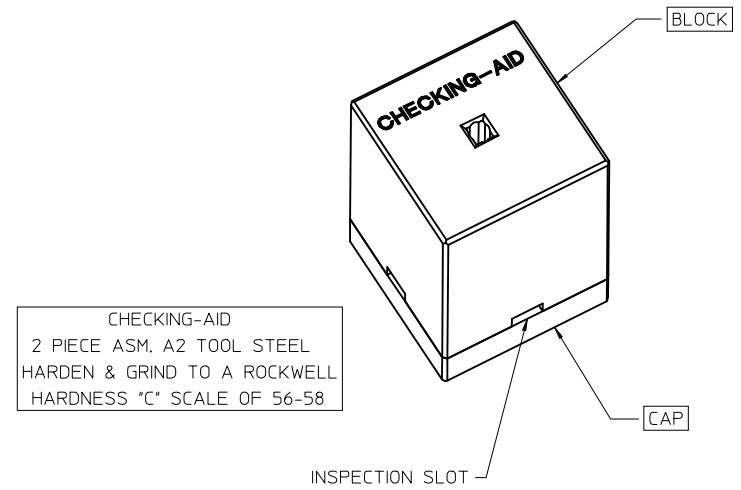
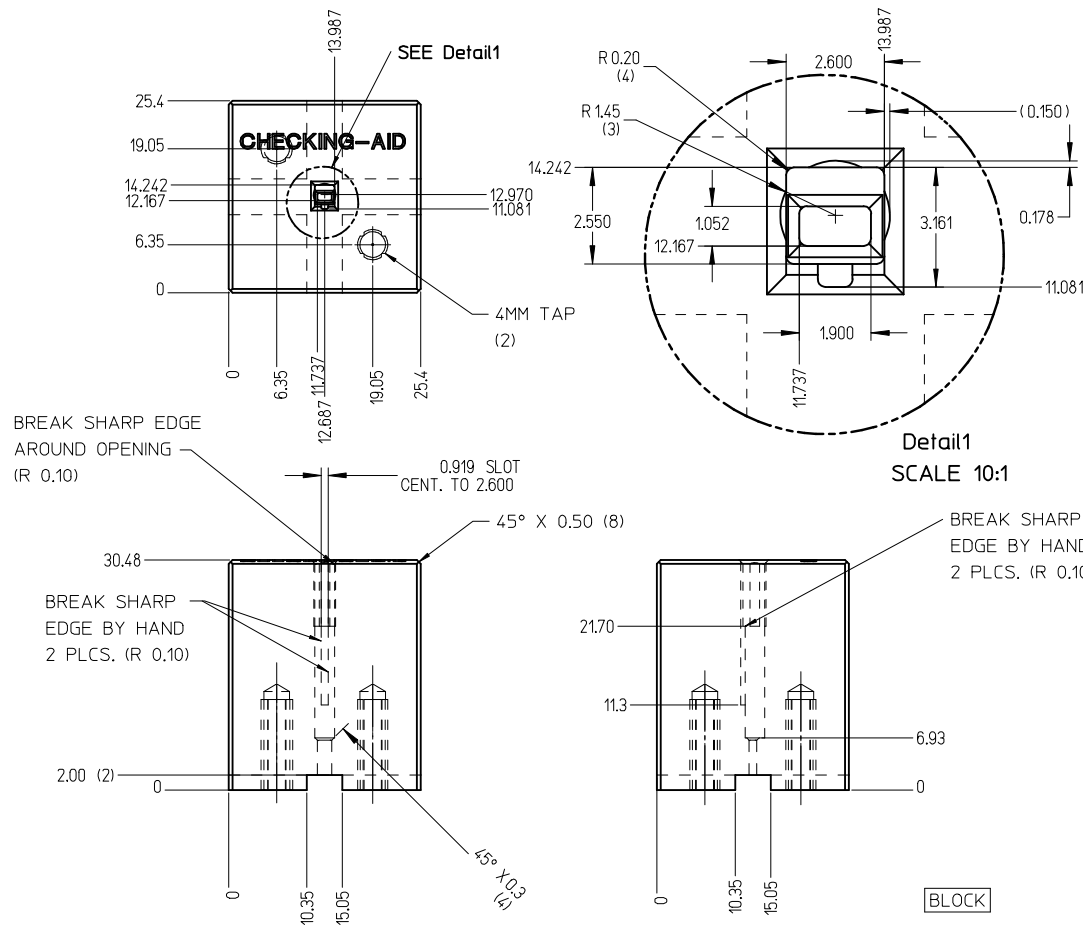

CHECKING-AID
 2 PIECE ASM. A2 TOOL STEEL
 HARDEN & GRIND TO A ROCKWELL
 HARDNESS "C" SCALE OF 56-58

CHECKING AID TOLERANCE
 .XXX = .005
 .XX = .03
 .X = .3

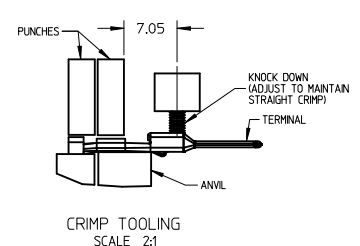
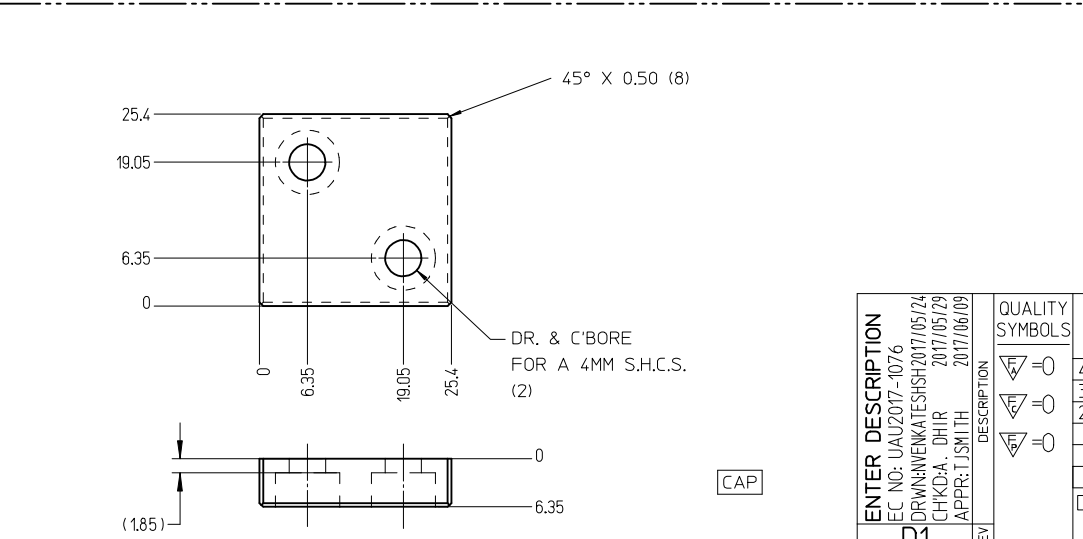

- CRIMP REQUIREMENTS:
1. CRIMP STRAIGHTNESS MUST BE MAINTAINED. USE A KNOCKDOWN TOOL LOCATED AS SHOWN. TERMINAL BOX MUST NOT BE DEFORMED
 2. AFTER CRIMPING, THE TERMINAL AND WIRE MUST FIT FREELY INTO THE CHECKING AID 33000-700. PROPER INSERTION DEPTH IS MET WHEN BLADE TIP STOPS ON CAP. SLOTS PROVIDED TO VISUALLY INSPECT STOPPAGE OF PIN TIP.
 3. FOR OTHER MECHANICAL REQUIREMENTS ON CRIMPED TERMINALS, REFER TO SAE/USCAR-21 (5-13-02) SECTIONS 4.2 (VISUAL INSPECTION), 4.3 (CROSS SECTION ANALYSIS) AND 4.4 (CONDUCTOR CRIMP PULLOUT FORCE)

REV	DESCRIPTION	QUALITY SYMBOLS
D1	ENTER DESCRIPTION EC NO: UAU2017-1076 DRWN:VENKATESH2017/05/24 CHKD:A. DHIR 2017/05/29 APPR:TJSM:TH 2017/06/09	▽=0 ▽=0 ▽=0

GENERAL TOLERANCES (UNLESS SPECIFIED)	
	mm INCH
4 PLACES ±	±
3 PLACES ±	±
2 PLACES ±	±0.10
1 PLACE ±	±0.3
0 PLACE ±	±
ANGULAR ± 3 °	
DRAFT WHERE APPLICABLE MUST REMAIN WITHIN DIMENSIONS	

DIMENSION STYLE MM ONLY	
DRAWN BY	DATE
L.PULLIAM	2006/01/31
CHECKED BY	DATE
A.DHIR	2006/02/01
APPROVED BY	DATE
B.MOSER	2006/02/02
MATERIAL NO.	
SEE TABLE	
SIZE	C

SCALE	2:1	DESIGN UNITS	METRIC	THIRD ANGLE PROJECTION
MX150 1.5MM BLADE TERMINAL				
molex			DOCUMENT NO.	SHEET NO.
SD-33000-001				3 OF 5
THIS DRAWING CONTAINS INFORMATION THAT IS PROPRIETARY TO MOLEX INCORPORATED AND SHOULD NOT BE USED WITHOUT WRITTEN PERMISSION				

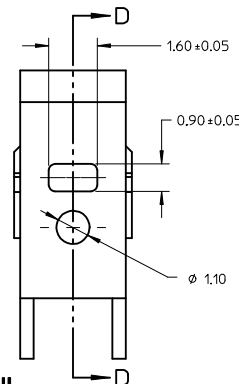
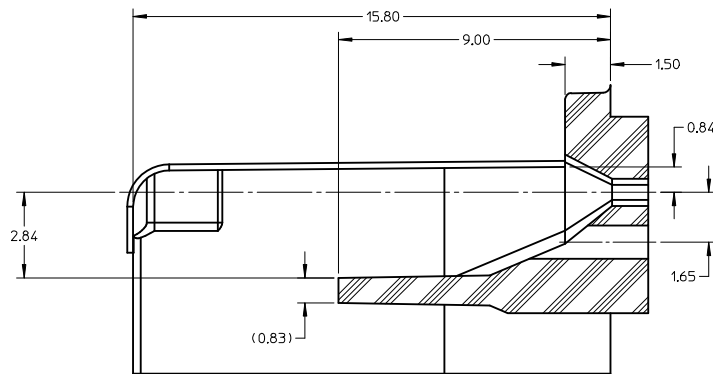
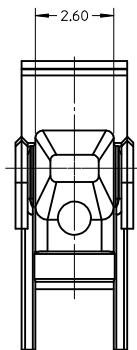

SECTION D-D TPA/INSERT DETAIL

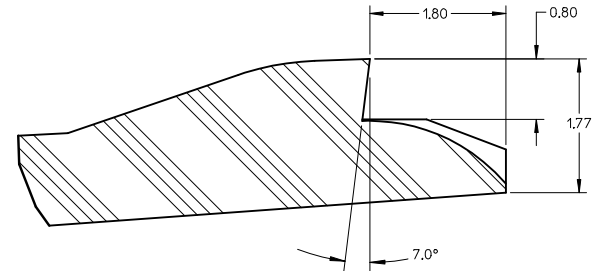
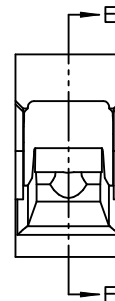
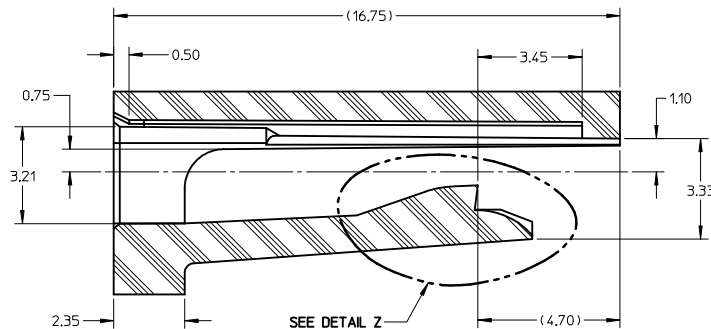
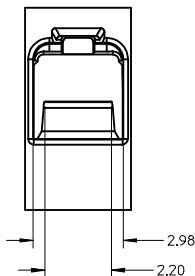

DETAIL Z SCALE 20:1

HOUSING DETAIL

NOTES: (UNLESS OTHERWISE SPECIFIED)

- TOLERANCES: LINEAR ± 0.10
ANGULAR 3°
- ALL DRAFT WITHIN TOLERANCE
- MAX RADI ON ALL CORNERS SHOWN SHARP: 0.10
- MAX FLASH PERMISSIBLE: 0.1
- EJECTOR PIN MARKS PERMISSIBLE IF FLUSH TO 0.25 BELOW SURFACE
- MATERIAL: HOUSING/FINGER SPECIFICATION ENGINEERED FOR MATERIAL WITH THE FOLLOWING PROPERTIES:
A. FLEXURAL MODULUS = 4,500 TO 9,400 MPa
PER ASTM TEST D790
B. ELONGATION AT YIELD = 2.3% OR BETTER
PER ASTM TEST D638 TYPE V
- CAVITY SPEC FOR USE ONLY WITH MOLEX BLADE TERMINAL PART NUMBERS (EXCEPT P/N'S FOR UNSEALED APPLICATIONS) SPECIFIED ELSEWHERE ON THIS DRAWING

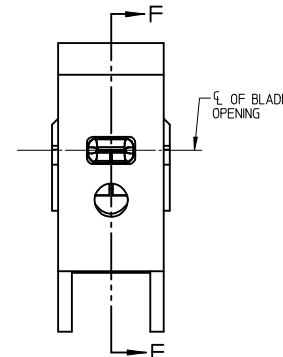
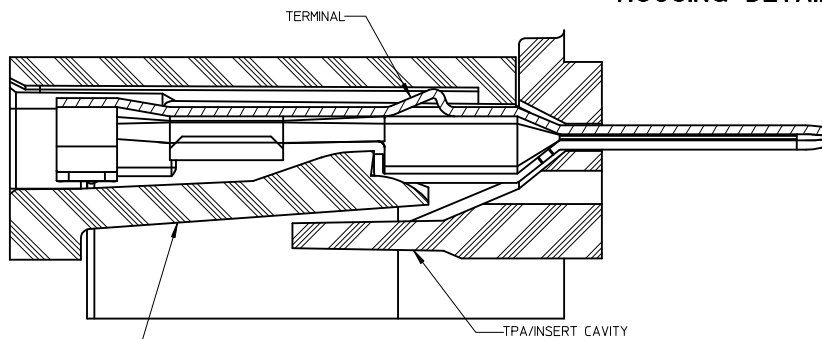
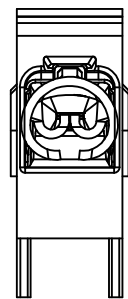

SECTION F-F

BLADE CAVITY ASSEMBLY VIEWS

ENTER DESCRIPTION EC NO: UAU2017-1076 DRWINVENKATESHSH2017/05/24 CHKD:A. DHIR 2017/05/29 APPR:TJSMITH 2017/06/09	QUALITY SYMBOLS ∇=0 ∇=0 ∇=0	GENERAL TOLERANCES (UNLESS SPECIFIED)		DIMENSION STYLE MM ONLY		SCALE	DESIGN UNITS METRIC	THIRD ANGLE PROJECTION	
		4 PLACES \pm --- \pm --- 3 PLACES \pm --- \pm --- 2 PLACES ± 0.10 \pm --- 1 PLACE ± 0.3 \pm --- 0 PLACE \pm \pm	mm INCH	DRAWN BY L.PULLIAM	DATE 2006/01/31	TITLE MX150 15MM BLADE TERMINAL			
		ANGULAR $\pm 3^\circ$		CHECKED BY A.DHIR	DATE 2006/02/01	molex			
		DRAFT WHERE APPLICABLE MUST REMAIN WITHIN DIMENSIONS		APPROVED BY B.MOSER	DATE 2006/02/02	MATERIAL NO. SEE TABLE	DOCUMENT NO. SD-33000-001	SHEET NO. 4 OF 5	
THIS DRAWING CONTAINS INFORMATION THAT IS PROPRIETARY TO MOLEX INCORPORATED AND SHOULD NOT BE USED WITHOUT WRITTEN PERMISSION									

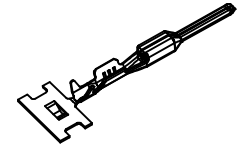

ISO VIEW
SCALE 2:1

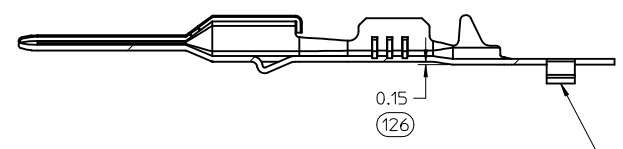
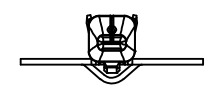
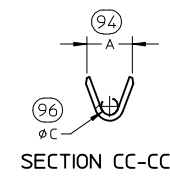
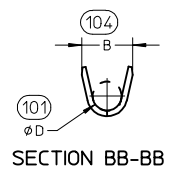
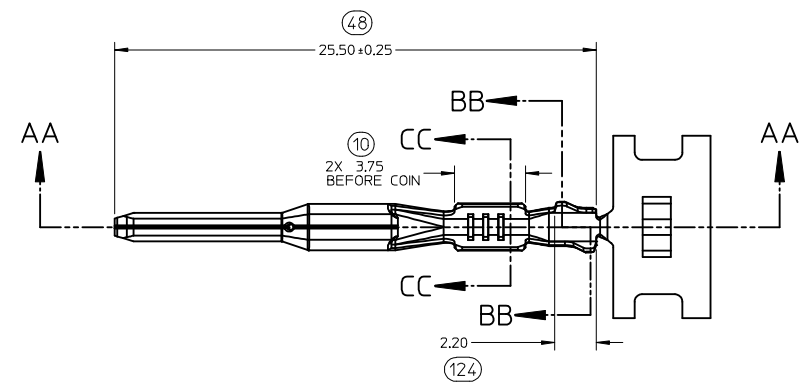

SECTION AA-AA
M3 GRIP CODE TERMINAL
SEE TABLE (SHEET 2) FOR PART NUMBERS

CARRIER BUMP DIRECTION
POINTS DOWN FOR TIN PLATED TERMINALS
POINTS UP FOR PRECIOUS METAL PLATED TERMINALS

ENTER DESCRIPTION EC NO: UAU2017-1076 DRW: NVENKATESHSH/2017/05/24 CHKD: A. DHIR 2017/05/29 APPR: T.JSMITH 2017/06/09 REV: D1	QUALITY SYMBOLS ▽=0 ▽=0 ▽=0	GENERAL TOLERANCES (UNLESS SPECIFIED) <table border="1"> <tr> <th></th> <th>mm</th> <th>INCH</th> </tr> <tr> <td>4 PLACES</td> <td>± ---</td> <td>± ---</td> </tr> <tr> <td>3 PLACES</td> <td>± ---</td> <td>± ---</td> </tr> <tr> <td>2 PLACES</td> <td>± 0.10</td> <td>± ---</td> </tr> <tr> <td>1 PLACE</td> <td>± 0.3</td> <td>± ---</td> </tr> </table> ANGULAR ± 3°		mm	INCH	4 PLACES	± ---	± ---	3 PLACES	± ---	± ---	2 PLACES	± 0.10	± ---	1 PLACE	± 0.3	± ---	DIMENSION STYLE MM ONLY DRAWN BY DATE L.PULLIAM 2006/01/31 CHECKED BY DATE A.DHIR 2006/02/01 APPROVED BY DATE B.MOSER 2006/02/02	SCALE 5:1	DESIGN UNITS METRIC	THIRD ANGLE PROJECTION
		mm	INCH																		
	4 PLACES	± ---	± ---																		
	3 PLACES	± ---	± ---																		
2 PLACES	± 0.10	± ---																			
1 PLACE	± 0.3	± ---																			
TITLE MX150 15MM BLADE TERMINAL																					
MATERIAL NO. SEE TABLE																					
DRAFT WHERE APPLICABLE MUST REMAIN WITHIN DIMENSIONS																					

MOLEX INCORPORATED
 DOCUMENT NO. **SD-33000-001** SHEET NO. **5 OF 5**
 THIS DRAWING CONTAINS INFORMATION THAT IS PROPRIETARY TO MOLEX INCORPORATED AND SHOULD NOT BE USED WITHOUT WRITTEN PERMISSION