

REVISIONS				
P	LTR	DESCRIPTION	DATE	APP'D
V		REVISED PER ECO-17-002903	20MAR2017	AP DG

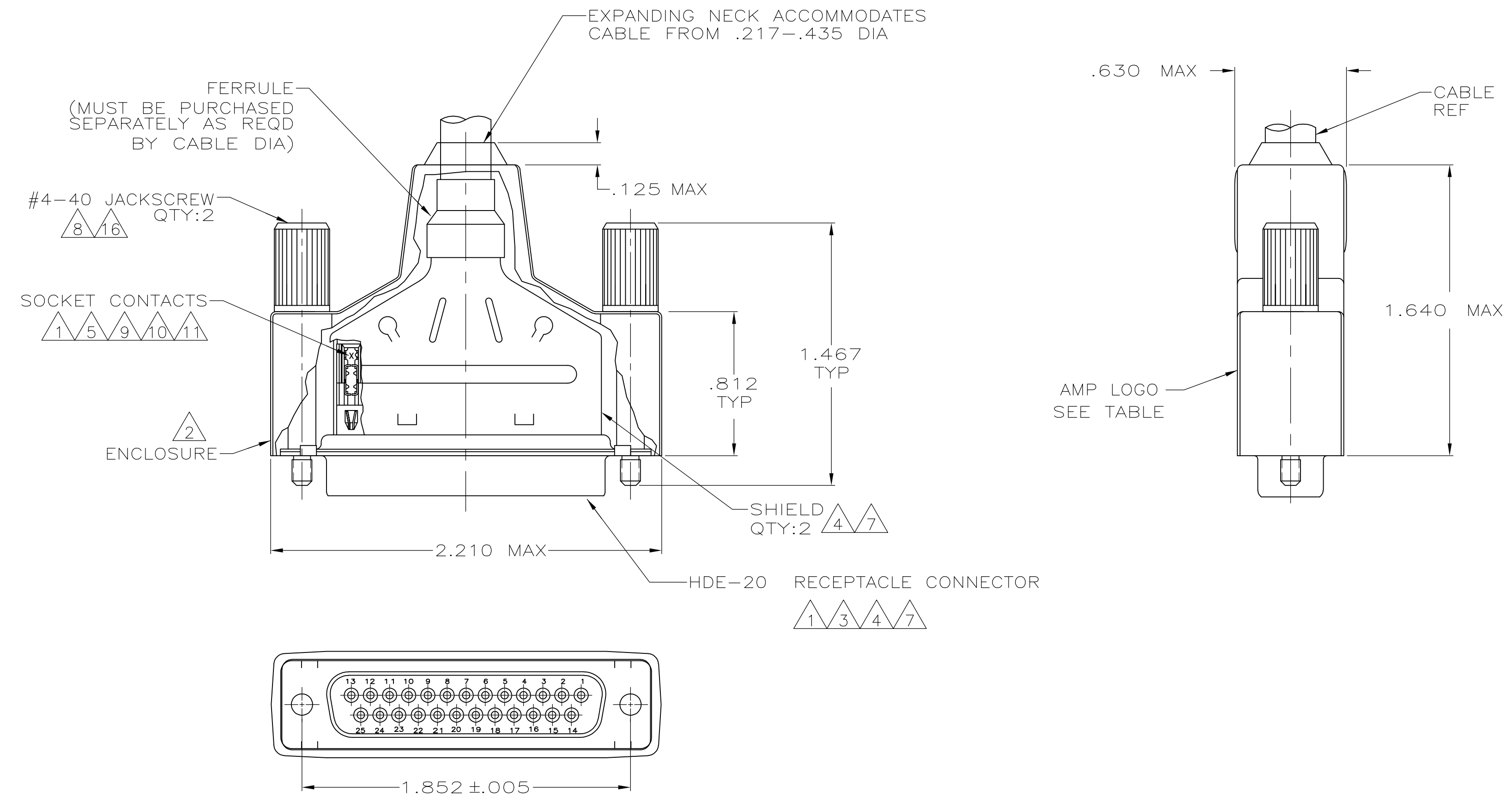

- 1 RECEPTACLE CONNECTOR FULLY LOADED WITH CONTACTS. ALL OTHER PARTS ARE SHIPPED UNASSEMBLED. EACH PART INDIVIDUALLY BULK PACKED.
- 2 FLAME RETARDANT 94V-0 RATED, POLYOLEFIN OR PVC, BLACK.
- 3 FLAME RETARDANT 94V-0 RATED, GLASS-FILLED, NYLON OR POLYESTER, BLACK.
- 4 STEEL PER ASTM A109.
- 5 PHOSPHOR BRONZE PER QQ-B-750.
- 6 GOLD PLATING PER MIL-G-45204, NICKEL PLATING PER QQ-N-290, TIN PLATING PER MIL-T-10727, ZINC PLATING PER B633, TYPE II, CLASS SCI, BLACK CHROMATE.
- 7 TIN PLATED.
- 8 BLACK ZINC FLAKE COATING.
- 9 PLATED WITH GOLD FLASH ON MATING END FOR LENGTH OF .100 MIN, .000100-.000200 TIN OR TIN LEAD ON TERMINATION END, ALL OVER .000030 MIN NICKEL ON ENTIRE CONTACT.
- 10 PLATED WITH .000030 GOLD FOR LENGTH OF .100 MIN FROM MATING END, WITH POINT OF MEASUREMENT .050 FROM MATING END OF CONTACT, .000100-.000200 TIN OR TIN LEAD ON TERMINATION END, ALL OVER .000030 MIN NICKEL ON ENTIRE CONTACT.
- 11 NUMBER ON CONTACT INDICATES WIRE RANGE.
- 12 OBSOLETE PART NUMBER.
- 13 SEE RESTRICTED CUSTOMER DRAWING 1-747947-3.
- 14 PLATED WITH .000030 GOLD FOR LENGTH OF .100 MIN FROM MATING END, .000100-.000200 TIN ON TERMINATION END, ALL OVER .000050 MIN NICKEL UNDERPLATE ON ENTIRE CONTACT.
- 15 PLATED WITH GOLD FLASH FOR A LENGTH OF .100 MIN FROM MATING END, .000100-.000200 TIN ON TERMINATION END, ALL OVER .000030 MIN NICKEL UNDERPLATE ON ENTIRE CONTACT.
- 16 CARBON STEEL, C1022.

CONTACT FINISH	LOGO	WIRE RANGE	PART NUMBER
			9-747947-1
15	YES	2 22-26	1-747947-7
14	YES	2 22-26	1-747947-6
14	YES	1 26-30	1-747947-5
	-	-	12 13
9	NO	3 20-22	1-747947-2
	NO	2 22-26	1-747947-1
	NO	1 26-30	1-747947-0
10	NO	3 20-22	747947-9
	NO	2 22-26	747947-8
	NO	1 26-30	747947-7
9	YES	3 20-22	747947-6
	YES	2 22-26	747947-5
	YES	1 26-30	747947-4
10	YES	3 20-22	747947-3
	YES	2 22-26	747947-2
	YES	1 26-30	747947-1

THIS DRAWING IS A CONTROLLED DOCUMENT.

DIMENSIONS: INCHES

TOLERANCES UNLESS OTHERWISE SPECIFIED:

0 PLC	± .001
1 PLC	± .002
2 PLC	± .003
3 PLC	± .004
4 PLC	± .005
ANGLES	± .001

MATERIAL: CONTACTS: SEE TABLE

FINISH: CONTACTS: SEE TABLE

WEIGHT: 0.000000

CUSTOMER DRAWING

APPROVED: L. VARELA - DOCKS, J. GFRACE, M. WALMSLEY

DATE: 11-17-04, 11-17-04, 11-17-04

NAME: M. WALMSLEY

PRODUCT SPEC: 108-40011 & 108-40030

APPLICATION SPEC: 114-40002

SIZE: A1

SCALE: 2:1

SHEET: 1 OF 1

REV: V

STE TE Connectivity

SHIELDING ENCLOSURE KIT, RECEPTACLE, SIZE 3, 25 POSN, AMPLIMITE HDE-20

# Mouser Electronics

Authorized Distributor

Click to View Pricing, Inventory, Delivery & Lifecycle Information:

[TE Connectivity:](#)

[1-747947-7](#)