

SYMBOL DEFINITION		MISSING SYMBOLS	
A DIMENSION WITHOUT AN INSPECTION REPORT SYMBOL ( ) DOES NOT REQUIRE INSPECTION. IT MAY BE CONTROLLED ON THE INDIVIDUAL COMPONENT DRAWING.	TOTAL NO OF INSPECTIONS REQUIRED	NO MISSING SYMBOL NUMBER	7
	LAST NO. USED		7

DWG STATUS					ZONE	REVISION HISTORY	AUTH	DR	APVD1	APVD2
DATE	STG	REV	N/P	CHG						
30JAO3	R	A4	-	-		CLEARED REVISION COLUMN & REDRAWN TO PD	236020	ECB	JVM	JDV
07FE03	R	A5	-	-		UPDATED PDM ATTRIBUTES	236143	EES	EES	JDV
18FE05	R	A6	-	-		ADDED PROCESSING NOTES	264890	JRA	JAA	MLP

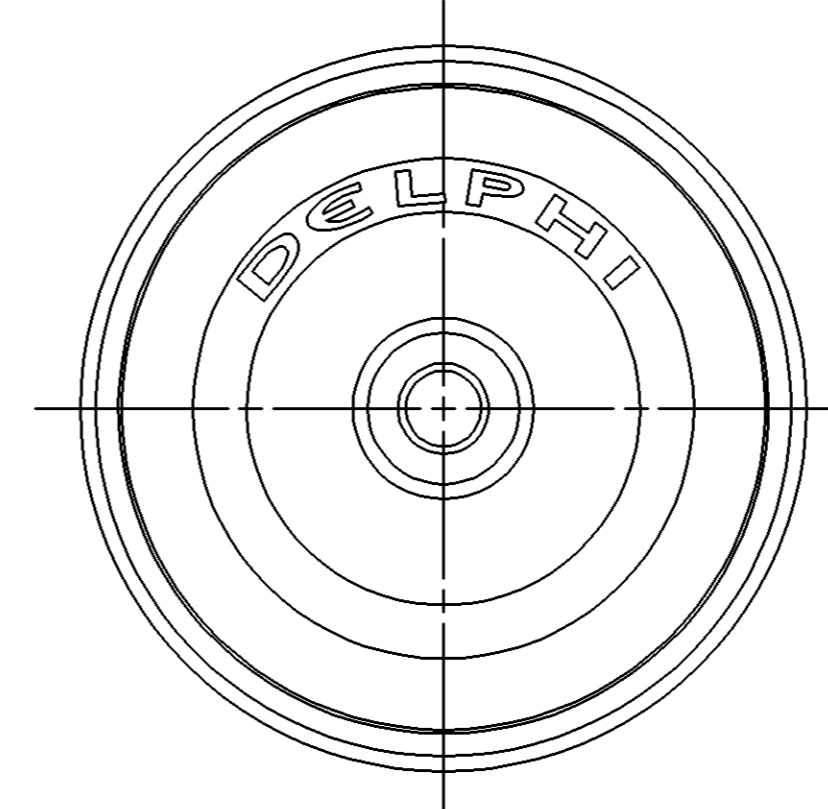
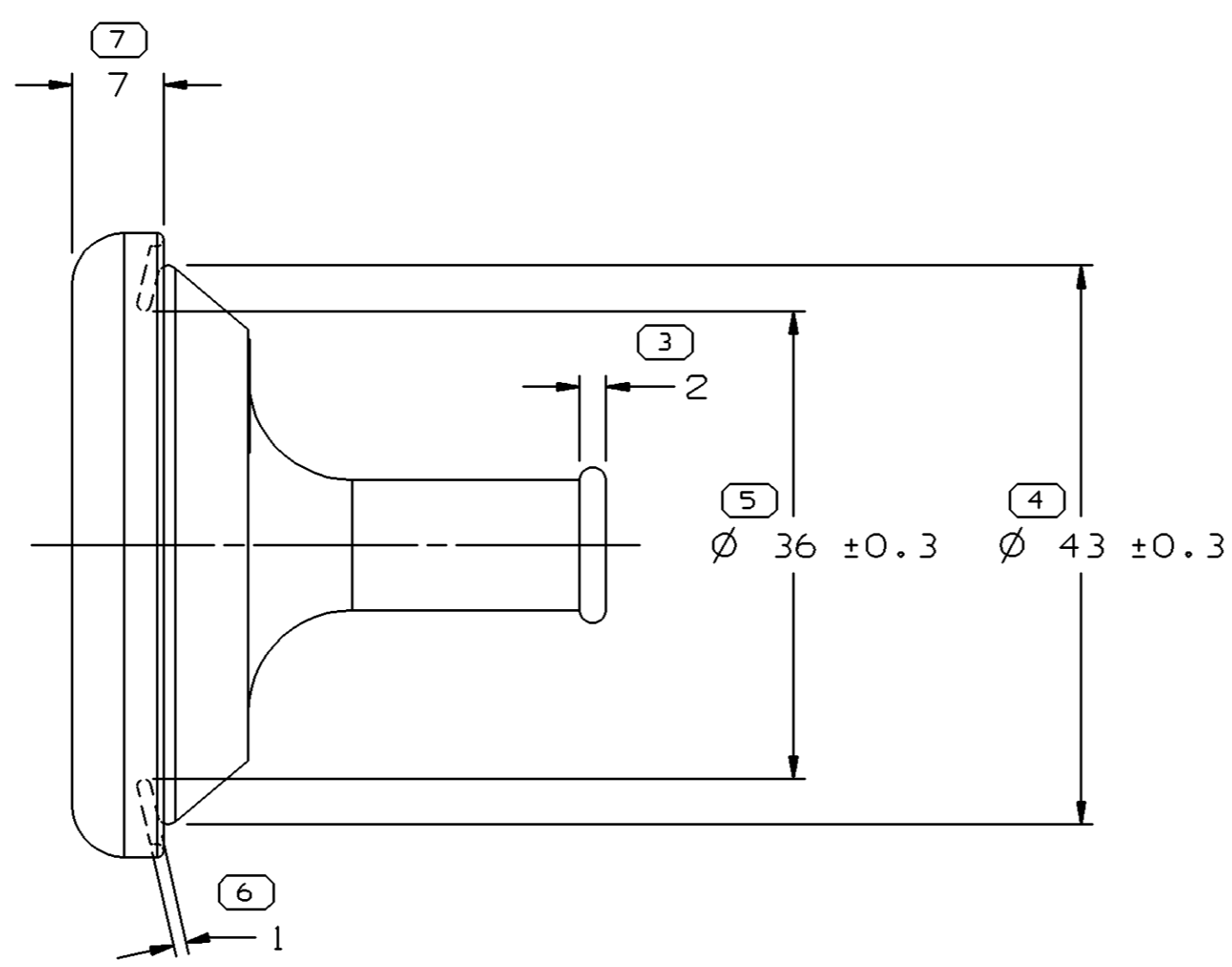
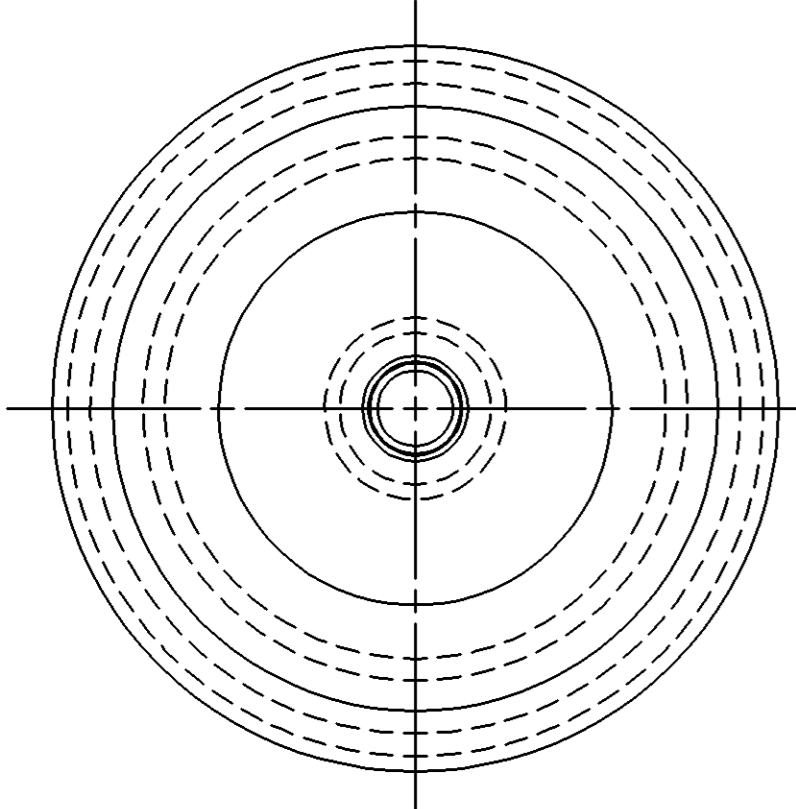
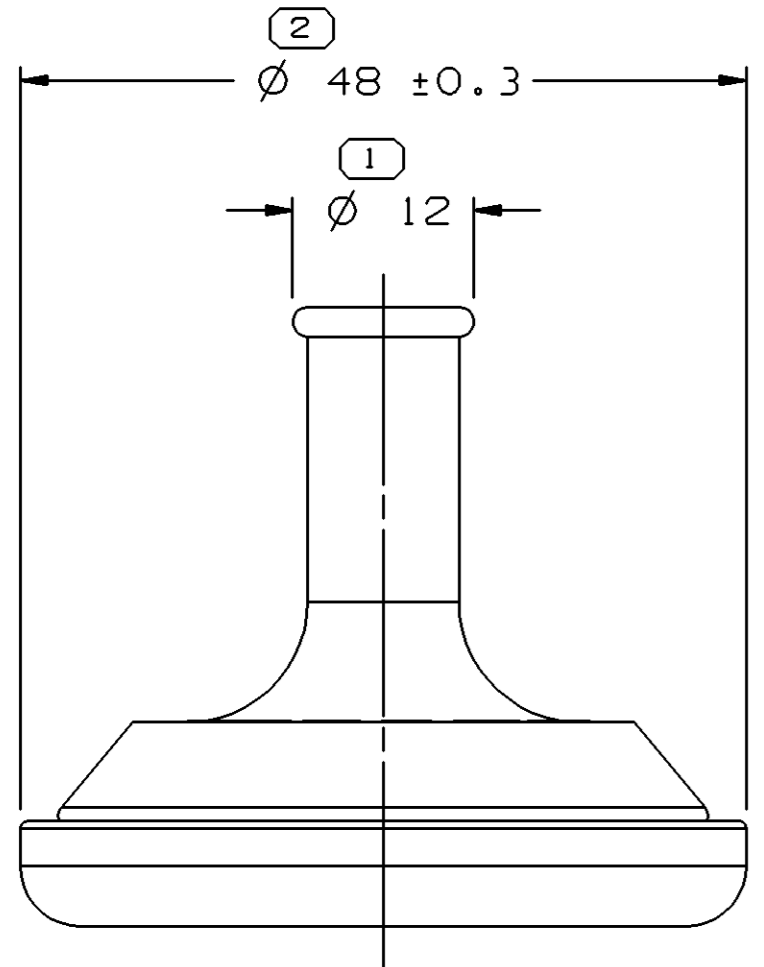

NOTES

- UNLESS OTHERWISE SPECIFIED AND/OR INDICATED:  
DIMENSIONS ARE TO FACE OF VIEW SHOWN AND AUTOMATICALLY ROUNDED BY COMPUTER FOR INSPECTION (SEE MATH MODEL FOR PRECISE DIMENSIONS). FOR ALL OTHER DIMENSIONS NOT SHOWN BUT REQUIRED FOR TOOL BUILD, SEE MATH MODEL FOR PRECISE TOOL PATH DATA.
- THIS PART IS NOT CONTROLLED FOR AUTOMATIC FEEDING.
- PART IS SYMMETRICAL ABOUT CENTERLINES EXCEPT AS NOTED.
- THIS PART MATES TO 36 ± 0.5 DIA HOLE IN 0.73/0.67 THICK SHEET METAL.
- THIS GROMMET TO BE USED WITH HARNESS BUNDLE SMOOTH TAPE WRAPPED USING 5 MIL TAPE HAVING NO SLITS ON EDGES.
- (2.3)X(0.1) DELPHI CORPORATE BRAND TO BE LOCATED ON ANY EXTERIOR SURFACE, PREFERABLY VISIBLE AT FINAL ASSEMBLY. OPTIONAL CONSTRUCTION TO BE "PED" OR NO LOGO.

PROCESSING NOTES

- THE FOLLOWING NUMBER IS TO BE PUT ON THE PRODUCT DRAWING AS THE MAXIMUM ALLOWABLE STRETCH DIMENSION: 20MM AS MEASURED IN THE FOLLOWING FASHION:

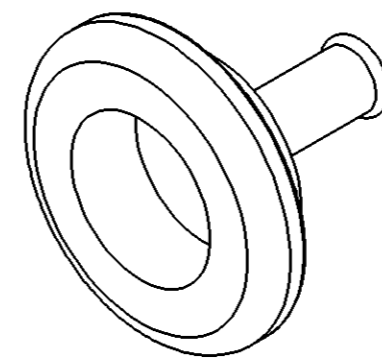
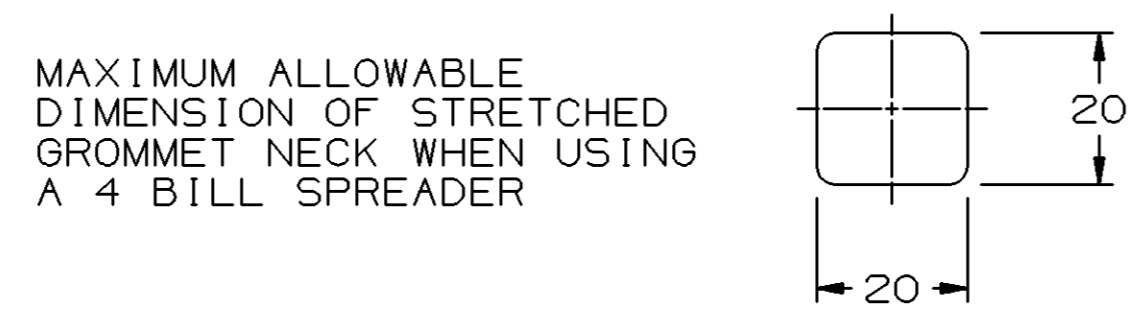

DIMENSIONAL RANGE (MM)		CHART	C
FROM	> 0	> 25	> 60
TO	25	60	80
TOLERANCE UNLESS OTHERWISE SPECIFIED			
	±0.3	±0.5	±0.6
			±0.75%
ANGULAR TOLERANCE ±2°			

DWG TYPE PART DRAWING	
STYLE	
VOLUME (CM³) 13.776	DISTR CODE D
UNLESS OTHERWISE SPECIFIED	
THIS DOCUMENT IS IN ACCORDANCE WITH ASME Y14.5M-1994 AS AMENDED BY THE GM GLOBAL DIMENSIONING AND TOLERANCING ADDENDUM - 1997. ALL GEOMETRIC TOLERANCES AND RELATED DATUMS APPLY RFS. RULE #1 PERFECT FORM AT MMC1 DOES NOT APPLY WHEN RELATIONSHIP BETWEEN FEATURES IS ESTABLISHED BY ORIENTATION OR LOCATION TOLERANCES. SEPARATE POSITION CALLOUTS MAY BE GAGED SEPARATELY, REGARDLESS OF DATUM REFERENCE. ALL DIMENSIONS ARE IN MILLIMETERS.	
REFERENCE 12045241	THIRD ANGLE PROJECTION
DO NOT SCALE	USE MATH DATA

<b>DELPHI</b>	
DELPHI PACKARD ELECTRIC SYSTEMS WARREN, OH	
DR COREY VANDOOZER	DATE 22SE90
APVD1 DAVE STEELE	22SE90
APVD2 JAMES C. GRIFFIN	27SE93
APVD3 R. PETROSKY	27SE93
APVD4	
APVD5	
SUBSTANCES OF CONCERN AND RECYCLED CONTENT PER DELPHI 10949001	
MATERIAL M4433002	
DRAWING NAME GROM	
DRAWING NUMBER 12110414	
SIZE A1	SCALE 2:1
FRAME NO 1 OF 1	SHEET NO 1 OF 1
STG R	REV A6
N/P -	

# Mouser Electronics

Authorized Distributor

Click to View Pricing, Inventory, Delivery & Lifecycle Information:

[Aptiv:](#)

[12110414](#)