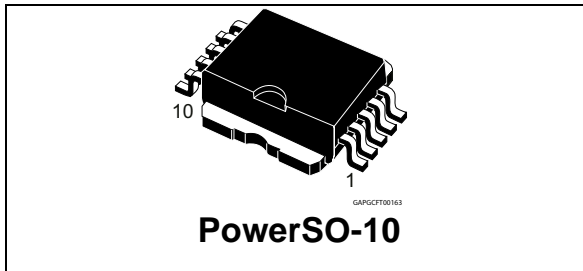


# Single-channel high-side driver with analog current sense for 24 V automotive applications

Datasheet – production data



## Features

Max transient supply voltage	$V_{CC}$	58 V
Operating voltage range	$V_{CC}$	8 V to 36 V
Typ on-state resistance	$R_{ON}$	6 m $\Omega$
Current limitation (typ)	$I_{LIM}$	115 A
Off-state supply current	$I_S$	2 $\mu$ A <sup>(1)</sup>

1. Typical value with all loads connected.

- AEC-Q100 qualified
- General
  - Very low standby current
  - 3 V CMOS compatible input
  - Optimized electromagnetic emission
  - Very low electromagnetic susceptibility
  - Compliance with 2002/95/EC European directive
  - Fault reset standby pin (FR\_Stby)
- Diagnostic functions
  - Proportional load current sense
  - Current sense precision for wide range currents
  - Off-state open-load detection
  - Output short to  $V_{CC}$  detection
  - Overload and short to ground latch-off
  - Thermal shutdown latch-off
  - Very low current sense leakage



- Protections
  - Undervoltage shutdown
  - Overvoltage clamp
  - Load current limitation
  - Self limiting of fast thermal transients
  - Protection against loss of ground and loss of  $V_{CC}$
  - Thermal shutdown
  - Reverse battery protected with self switch of the PowerMOS
  - Electrostatic discharge protection

## Application

- All types of resistive, inductive and capacitive loads

## Description

The VN5T006ASP-E is a device made using STMicroelectronics® VIPower® technology, intended for driving resistive or inductive loads with one side connected to ground. Active  $V_{CC}$  pin voltage clamp protects the device against low energy spikes.

This device integrates an analog current sense which delivers a current proportional to the load current. Fault conditions such as overload, overtemperature or short to  $V_{CC}$  are reported via the current sense pin.

Output current limitation protects the device in overload condition. The device latches off in case of overload or thermal shutdown.

The device is reset by a low-level pass on the fault reset standby pin.

A permanent low level on the inputs and fault reset standby pin disables all outputs and sets the device in standby mode.

# Contents

- 1        Block diagram and pin description ..... 5**
- 2        Electrical specifications ..... 7**
  - 2.1    Absolute maximum ratings ..... 7
  - 2.2    Thermal data ..... 8
  - 2.3    Electrical characteristics ..... 9
  - 2.4    Electrical characteristics curves ..... 19
- 3        Application information ..... 21**
  - 3.1    Load dump protection ..... 21
  - 3.2    MCU I/Os protection ..... 21
  - 3.3    Maximum demagnetization energy (VCC = 24 V) ..... 22
- 4        Package and PCB thermal data ..... 23**
  - 4.1    PowerSO-10 thermal data ..... 23
- 5        Package information ..... 26**
  - 5.1    ECOPACK® ..... 26
  - 5.2    PowerSO-10 mechanical data ..... 26
  - 5.3    Packing information ..... 28
- 6        Order codes ..... 29**
- 7        Revision history ..... 30**

## List of tables

Table 1.	Pin function . . . . .	5
Table 2.	Suggested connections for unused and not connected pins . . . . .	6
Table 3.	Absolute maximum ratings . . . . .	7
Table 4.	Thermal data . . . . .	8
Table 5.	Power section . . . . .	9
Table 6.	Switching ( $V_{CC} = 24\text{ V}$ ; $T_j = 25^\circ\text{C}$ ) . . . . .	9
Table 7.	Logic inputs . . . . .	10
Table 8.	Protections and diagnostics . . . . .	11
Table 9.	Current sense ( $8\text{ V} < V_{CC} < 36\text{ V}$ ) . . . . .	12
Table 10.	Open-load detection ( $FR\_Stby = 5\text{ V}$ ) . . . . .	13
Table 11.	Truth table . . . . .	17
Table 12.	Electrical transient requirements (part 1) . . . . .	18
Table 13.	Electrical transient requirements (part 2) . . . . .	18
Table 14.	Electrical transient requirements (part 3) . . . . .	18
Table 15.	Thermal parameters . . . . .	25
Table 16.	PowerSO-10 mechanical data . . . . .	27
Table 17.	Device summary . . . . .	29
Table 18.	Document revision history . . . . .	30

## List of figures

Figure 1.	Block diagram . . . . .	5
Figure 2.	Configuration diagram (top view) . . . . .	6
Figure 3.	Current and voltage conventions . . . . .	7
Figure 4.	$T_{\text{reset}}$ definition . . . . .	10
Figure 5.	$T_{\text{stby}}$ definition . . . . .	11
Figure 6.	Output stuck to $V_{\text{CC}}$ detection delay time at $\text{FR}_{\text{STBY}}$ activation . . . . .	14
Figure 7.	Current sense delay characteristics . . . . .	14
Figure 8.	Open-load off-state delay timing . . . . .	15
Figure 9.	Switching characteristics . . . . .	15
Figure 10.	Delay response time between rising edge of output current and rising edge of current sense . . . . .	16
Figure 11.	Output voltage drop limitation . . . . .	16
Figure 12.	Device behavior in overload condition . . . . .	17
Figure 13.	Off-state output current . . . . .	19
Figure 14.	High level input current . . . . .	19
Figure 15.	Input clamp voltage . . . . .	19
Figure 16.	Input low level voltage . . . . .	19
Figure 17.	Input high level voltage . . . . .	19
Figure 18.	Input hysteresis voltage . . . . .	19
Figure 19.	On state resistance vs $T_{\text{case}}$ . . . . .	20
Figure 20.	On state resistance vs $V_{\text{CC}}$ . . . . .	20
Figure 21.	$I_{\text{LIMH}}$ vs $T_{\text{case}}$ . . . . .	20
Figure 22.	Turn-On voltage slope . . . . .	20
Figure 23.	Turn-Off voltage slope . . . . .	20
Figure 24.	Application schematic . . . . .	21
Figure 25.	Maximum turn-off current versus inductance . . . . .	22
Figure 26.	PowerSO-10 PC board . . . . .	23
Figure 27.	$R_{\text{thj-amb}}$ vs PCB copper area in open box free air condition (one channel on) . . . . .	23
Figure 28.	PowerSO-10 thermal impedance junction ambient single pulse (one channel on) . . . . .	24
Figure 29.	Thermal fitting model of a double channel HSD in PowerSO-10 . . . . .	24
Figure 30.	PowerSO-10 package dimensions . . . . .	26
Figure 31.	PowerSO-10 suggested pad layout and tube shipment (no suffix) . . . . .	28
Figure 32.	PowerSO-10 tape and reel shipment (suffix "TR") . . . . .	28

# 1 Block diagram and pin description

Figure 1. Block diagram

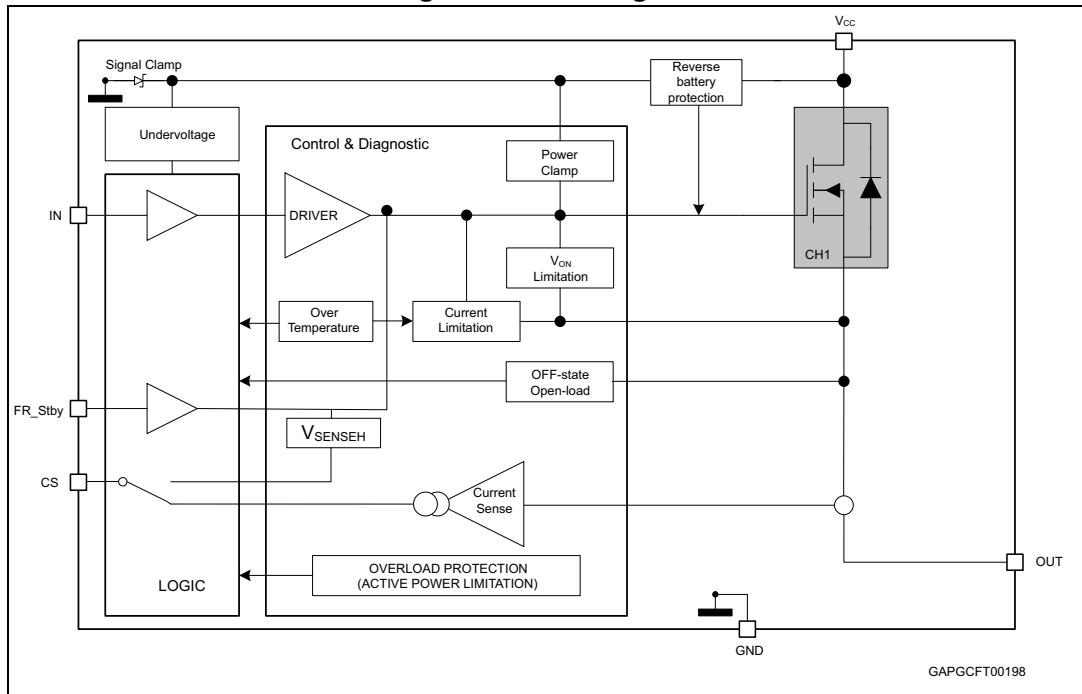


Table 1. Pin function

Name	Function
V <sub>CC</sub>	Battery connection.
OUT	Power output.
GND	Ground connection.
IN	Voltage controlled input pin with hysteresis, CMOS compatible; it controls output switch state.
CS	Analog current sense pin; it delivers a current proportional to the load current.
FR_Stby	In case of latch-off for overtemperature /overcurrent condition, a low pulse on the FR_Stby pin is needed to reset the channel. The device enters in standby mode if all inputs and the FR_Stby pin are low.

Figure 2. Configuration diagram (top view)

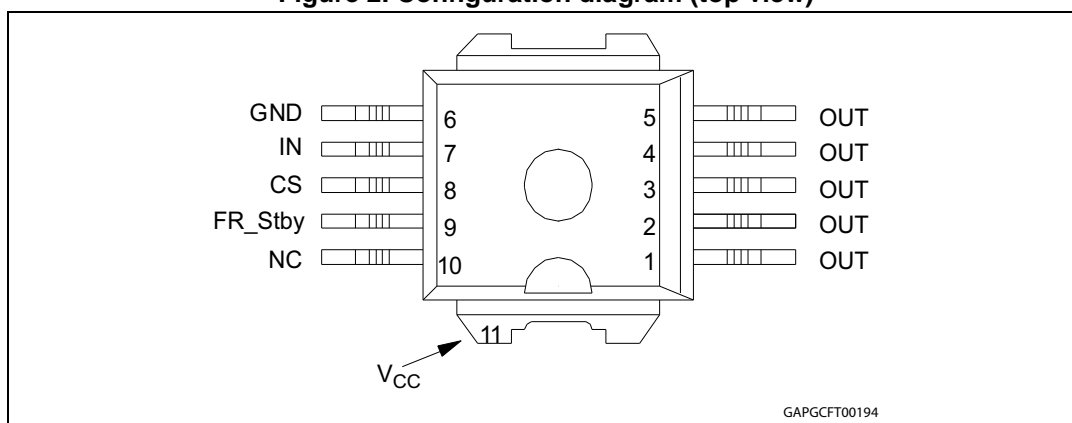


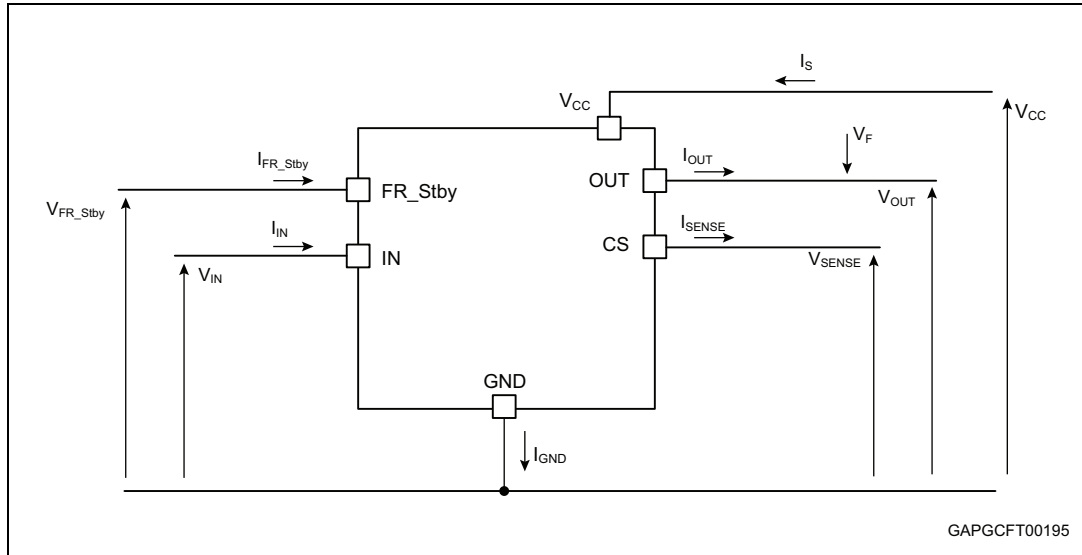
Table 2. Suggested connections for unused and not connected pins

Connection / pin	CS	N.C.	OUT	IN	FR_Stby
Floating	Not allowed	X <sup>(1)</sup>	X	X	X
To ground	Through 10 K $\Omega$ resistor	X	Not allowed	Through 10 K $\Omega$ resistor	Through 10 K $\Omega$ resistor

1. X: do not care.

## 2 Electrical specifications

Figure 3. Current and voltage conventions



### 2.1 Absolute maximum ratings

Stressing the device above the ratings listed in [Table 3](#) may cause permanent damage to the device. These are stress ratings only and operation of the device at these or any other conditions above those indicated in the operating sections of this specification is not implied. Exposure to the conditions reported in this section for extended periods may affect device reliability.

Table 3. Absolute maximum ratings

Symbol	Parameter	Value	Unit
$V_{CC}$	DC supply voltage	58	V
$-V_{CC}$	Reverse DC supply voltage	-32	V
$I_{OUT}$	DC output current	Internally limited	A
$-I_{OUT}$	Reverse DC output current	90	A
$I_{IN}$	DC input current	-1 to 10	mA
$I_{FR\_Stby}$	Fault reset standby DC input current	-1 to 1.5	mA
$V_{CSense}$	Current sense maximum voltage	$V_{CC} - 58$ to $+V_{CC}$	V
$E_{MAX}$	Maximum switching energy ( $L = 10$ mH; $V_{bat} = 32$ V; $T_{jstart} = 150^{\circ}C$ ; $I_{OUT} = 8.9$ A)	880	mJ
$L_{SMAX}$	Maximum stray inductance in short circuit condition $V_{bat} = 32$ V; $R_L = 300$ m $\Omega$ ; $T_{jstart} = 150^{\circ}C$ ; $I_{OUT} = I_{limH\_max}$	40	$\mu$ H

Table 3. Absolute maximum ratings (continued)

Symbol	Parameter	Value	Unit
V <sub>ESD</sub>	Electrostatic discharge (human body model: R = 1.5 KΩ; C = 100 pF)		
	– IN	4000	V
	– CS	2000	V
	– FR_Stby	4000	V
	– OUT	5000	V
	– V <sub>CC</sub>	5000	V
V <sub>ESD</sub>	Charge device model (CDM-AEC-Q100-011)	750	V
T <sub>j</sub>	Junction operating temperature	-40 to 150	°C
T <sub>stg</sub>	Storage temperature	-55 to 150	°C

## 2.2 Thermal data

Table 4. Thermal data

Symbol	Parameter	Value	Unit
R <sub>thj-case</sub>	Thermal resistance junction-case (max.) (with one channel on)	0.8	°C/W
R <sub>thj-amb</sub>	Thermal resistance junction-ambient (max.)	See <a href="#">Figure 27</a>	°C/W



## 2.3 Electrical characteristics

$8\text{ V} < V_{CC} < 36\text{ V}$ ;  $-40^\circ\text{C} < T_j < 150^\circ\text{C}$ , unless otherwise specified.

**Table 5. Power section**

Symbol	Parameter	Test conditions	Min.	Typ.	Max.	Unit
$V_{CC}$	Operating supply voltage		8	24	36	V
$V_{USD}$	Undervoltage shutdown			3.5	5	V
$V_{USDhyst}$	Undervoltage shutdown hysteresis			0.5		V
$R_{ON}$	On-state resistance <sup>(2)</sup>	$I_{OUT} = 10\text{ A}$ ; $T_j = 25^\circ\text{C}$ ; $8\text{ V} < V_{CC} < 36\text{ V}$		6		m $\Omega$
		$I_{OUT} = 10\text{ A}$ ; $T_j = 150^\circ\text{C}$ ; $8\text{ V} < V_{CC} < 36\text{ V}$			12	
$R_{ON REV}$	Reverse battery on-state resistance	$V_{CC} = -24\text{ V}$ ; $I_{OUT} = -10\text{ A}$ ; $T_j = 25^\circ\text{C}$			6	m $\Omega$
$V_{clamp}$	Clamp voltage	$I_S = 20\text{ mA}$	58	64	70	V
$I_S$	Supply current	Off-state: $V_{CC} = 24\text{ V}$ ; $T_j = 25^\circ\text{C}$ ; $V_{IN} = V_{OUT} = V_{SENSE} = 0\text{ V}$		2 <sup>(1)</sup>	5	$\mu\text{A}$
		On-state: $V_{CC} = 24\text{ V}$ ; $V_{IN} = 5\text{ V}$ ; $I_{OUT} = 0\text{ A}$		3	6	mA
$I_{L(off1)}$	Off-state output current	$V_{IN} = V_{OUT} = 0\text{ V}$ ; $V_{CC} = 24\text{ V}$ ; $T_j = 25^\circ\text{C}$	0	0.01	3	$\mu\text{A}$
		$V_{IN} = V_{OUT} = 0\text{ V}$ ; $V_{CC} = 24\text{ V}$ ; $T_j = 125^\circ\text{C}$	0		5	

1. PowerMOS leakage included.

**Table 6. Switching ( $V_{CC} = 24\text{ V}$ ;  $T_j = 25^\circ\text{C}$ )**

Symbol	Parameter	Test conditions	Min.	Typ.	Max.	Unit
$t_{d(on)}$	Turn-on delay time	$R_L = 2.4\ \Omega$	—	32	—	$\mu\text{s}$
$t_{d(off)}$	Turn-off delay time	$R_L = 2.4\ \Omega$	—	67	—	$\mu\text{s}$
$dV_{OUT}/dt_{(on)}$	Turn-on voltage slope	$R_L = 2.4\ \Omega$		0.7		V/ $\mu\text{s}$
$dV_{OUT}/dt_{(off)}$	Turn-off voltage slope	$R_L = 2.4\ \Omega$		0.46		V/ $\mu\text{s}$
$W_{ON}$	Switching energy losses during $t_{won}$	$R_L = 2.4\ \Omega$	—	4.15	—	mJ
$W_{OFF}$	Switching energy losses during $t_{woff}$	$R_L = 2.4\ \Omega$	—	2.7	—	mJ

Table 7. Logic inputs

Symbol	Parameter	Test conditions	Min.	Typ.	Max.	Unit
$V_{IL}$	Low-level input voltage				0.9	V
$I_{IL}$	Low-level input current	$V_{IN} = 0.9\text{ V}$	1			$\mu\text{A}$
$V_{IH}$	High-level input voltage		2.1			V
$I_{IH}$	High-level input current	$V_{IN} = 2.1\text{ V}$			10	$\mu\text{A}$
$V_{I(hyst)}$	Input hysteresis voltage		0.25			V
$V_{ICL}$	Input clamp voltage	$I_{IN} = 1\text{ mA}$	5.5		7	V
		$I_{IN} = -1\text{ mA}$		-0.7		
$V_{FR\_Stby\_L}$	Low-level fault-reset-standby voltage				0.9	V
$I_{FR\_Stby\_L}$	Low-level fault-reset-standby current	$V_{FR\_Stby} = 0.9\text{ V}$	1			$\mu\text{A}$
$V_{FR\_Stby\_H}$	High-level fault-reset-standby voltage		2.1			V
$I_{FR\_Stby\_H}$	High-level fault-reset-standby current	$V_{FR\_Stby} = 2.1\text{ V}$			10	$\mu\text{A}$
$V_{FR\_Stby(hyst)}$	Fault-reset-standby hysteresis voltage		0.25			V
$V_{FR\_Stby\_CL}$	Fault-reset-standby clamp voltage	$I_{FR\_Stby} = 15\text{ mA (10 ms)}$	11		15	V
		$I_{FR\_Stby} = -1\text{ mA}$		-0.7		
$t_{reset}$	Overload latch-off reset time	See <a href="#">Figure 4</a>	2		24	$\mu\text{s}$
$t_{stby}$	Standby delay	See <a href="#">Figure 5</a>	120		1200	$\mu\text{s}$

Figure 4.  $T_{reset}$  definition

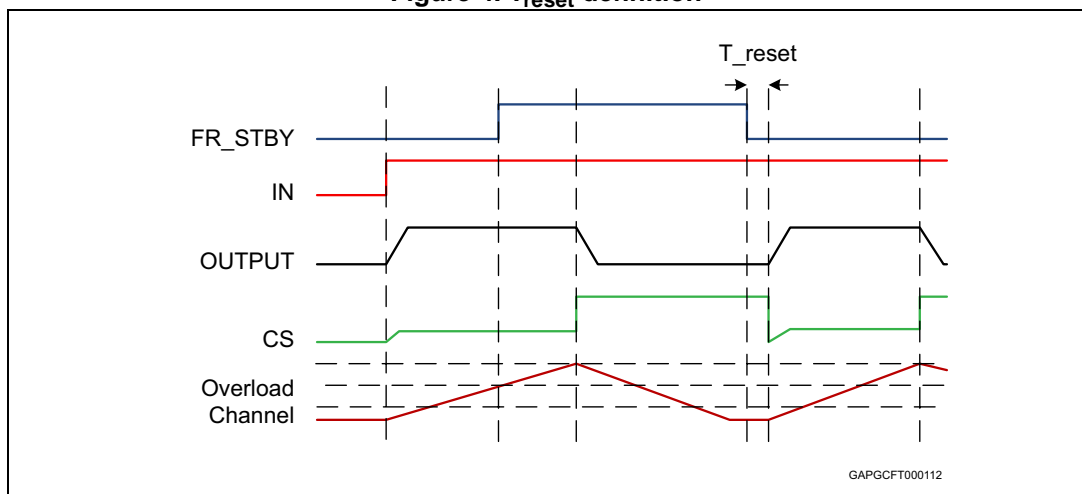


Figure 5.  $T_{stby}$  definition

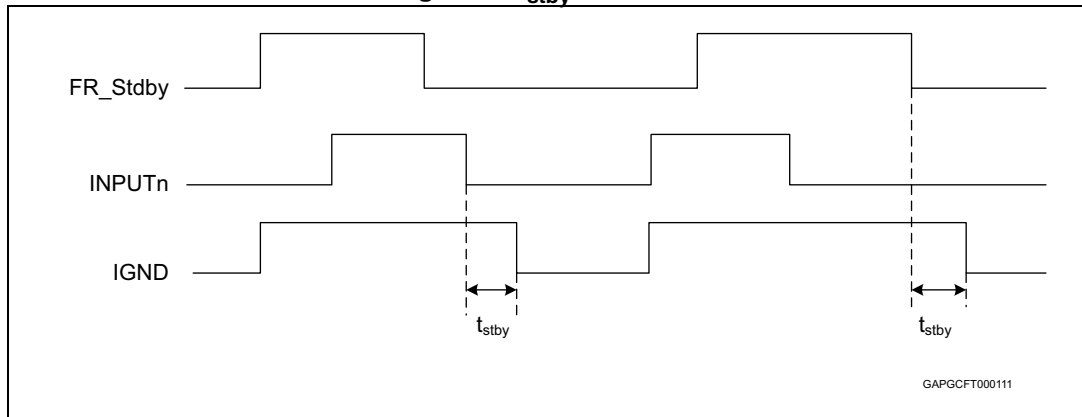


Table 8. Protections and diagnostics

Symbol	Parameter	Test conditions	Min.	Typ.	Max.	Unit
$I_{limH}$	DC short-circuit current	$V_{CC} = 24\text{ V}$	81	115	162	A
		$5\text{ V} < V_{CC} < 36\text{ V}$			162	A
$I_{limL}$	Short-circuit current during thermal cycling	$V_{CC} = 24\text{ V}; T_R < T_j < T_{TSD}$		29		A
$T_{TSD}$	Shutdown temperature		150	175	200	°C
$T_R$	Reset temperature		$T_{RS} + 1$	$T_{RS} + 5$		°C
$T_{RS}$	Thermal reset of status		135			°C
$T_{HYST}$	Thermal hysteresis ( $T_{TSD} - T_R$ )			7		°C
$V_{DEMAG}$	Turn-off output voltage clamp	$I_{OUT} = 10\text{ A}; V_{IN} = 0\text{ V}; L = 6\text{ mH}$	$V_{CC} - 58$	$V_{CC} - 64$	$V_{CC} - 70$	V
$V_{ON}$	Output voltage drop limitation	$I_{OUT} = 1\text{ A}; T_j = -40^\circ\text{C to } 150^\circ\text{C}$		25		mV

Table 9. Current sense (8 V < V<sub>CC</sub> < 36 V)

Symbol	Parameter	Test conditions	Min.	Typ.	Max.	Unit
K <sub>0</sub>	I <sub>OUT</sub> /I <sub>SENSE</sub>	I <sub>OUT</sub> = 0.6 A; V <sub>SENSE</sub> = 0.5 V; T <sub>j</sub> = -40°C to 150°C T <sub>j</sub> = 25°C to 150°C	3930 5035	11250	19850 17055	
dK <sub>0</sub> /K <sub>0</sub> <sup>(1)</sup>	Current sense ratio drift	I <sub>OUT</sub> = 0.6 A; V <sub>SENSE</sub> = 0.5 V; T <sub>j</sub> = -40°C to 150°C	-30		30	%
K <sub>1</sub>	I <sub>OUT</sub> /I <sub>SENSE</sub>	I <sub>OUT</sub> = 1.6 A; V <sub>SENSE</sub> = 1 V; T <sub>j</sub> = -40°C to 150°C; T <sub>j</sub> = 25°C to 150°C	5600 6215	10750	16940 14660	
dK <sub>1</sub> /K <sub>1</sub> <sup>(1)</sup>	Current sense ratio drift	I <sub>OUT</sub> = 1.6 A; V <sub>SENSE</sub> = 1 V; T <sub>j</sub> = -40°C to 150°C	-28		25	%
K <sub>2</sub>	I <sub>OUT</sub> /I <sub>SENSE</sub>	I <sub>OUT</sub> = 2.4 A; V <sub>SENSE</sub> = 1 V; T <sub>j</sub> = -40°C to 150°C T <sub>j</sub> = 25°C to 150°C	6030 6200	10370	15865 13635	
dK <sub>2</sub> /K <sub>2</sub> <sup>(1)</sup>	Current sense ratio drift	I <sub>OUT</sub> = 2.4 A; V <sub>SENSE</sub> = 1 V; T <sub>j</sub> = -40°C to 150°C	-26		23	%
K <sub>3</sub>	I <sub>OUT</sub> /I <sub>SENSE</sub>	I <sub>OUT</sub> = 3 A; V <sub>SENSE</sub> = 2 V; T <sub>j</sub> = -40°C to 150°C T <sub>j</sub> = 25°C to 150°C	6040 6040	10070	15285 13090	
dK <sub>3</sub> /K <sub>3</sub> <sup>(1)</sup>	Current sense ratio drift	I <sub>OUT</sub> = 3 A; V <sub>SENSE</sub> = 2 V; T <sub>j</sub> = -40°C to 150°C	-25		22	%
K <sub>4</sub>	I <sub>OUT</sub> /I <sub>SENSE</sub>	I <sub>OUT</sub> = 6 A; V <sub>SENSE</sub> = 4 V; T <sub>j</sub> = -40°C to 150°C T <sub>j</sub> = 25°C to 150°C	5845 6000	8670	13630 10895	
dK <sub>4</sub> /K <sub>4</sub> <sup>(1)</sup>	Current sense ratio drift	I <sub>OUT</sub> = 6 A; V <sub>SENSE</sub> = 4 V; T <sub>j</sub> = -40°C to 150°C	-20		20	%
K <sub>5</sub>	I <sub>OUT</sub> /I <sub>SENSE</sub>	I <sub>OUT</sub> = 10 A; V <sub>SENSE</sub> = 4 V; T <sub>j</sub> = -40°C to 150°C T <sub>j</sub> = 25°C to 150°C	5920 6730	8400	11520 9765	
dK <sub>5</sub> /K <sub>5</sub> <sup>(1)</sup>	Current sense ratio drift	I <sub>OUT</sub> = 10 A; V <sub>SENSE</sub> = 4 V; T <sub>j</sub> = -40°C to 150°C	-15		15	%
K <sub>6</sub>	I <sub>OUT</sub> /I <sub>SENSE</sub>	I <sub>OUT</sub> = 20 A; V <sub>SENSE</sub> = 4 V; T <sub>j</sub> = -40°C to 150°C	6960	8330	10090	
dK <sub>6</sub> /K <sub>6</sub> <sup>(1)</sup>	Current sense ratio drift	I <sub>OUT</sub> = 20 A; V <sub>SENSE</sub> = 4 V; T <sub>j</sub> = -40°C to 150°C	-8		8	%
dK/K <sub>BULB1</sub> <sup>(1)</sup>	Current sense ratio drift	I <sub>OUT</sub> = 0.6 A to 6 A; I <sub>CAL</sub> = 3 A; V <sub>SENSE</sub> = 0.5 V; T <sub>j</sub> = -40°C to 150°C	-30		50	%
dK/K <sub>BULB2</sub> <sup>(1)</sup>	Current sense ratio drift	I <sub>OUT</sub> = 1.6 A to 4.2 A; I <sub>OUTCAL</sub> = 3 A; V <sub>SENSE</sub> = 2 V; T <sub>j</sub> = -40°C to 150°C	-30		26	%
dK/K <sub>BULB3</sub> <sup>(1)</sup>	Current sense ratio drift	I <sub>OUT</sub> = 0.6 A to 2.4 A; I <sub>OUTCAL</sub> = 1.6 A; V <sub>SENSE</sub> = 2 V; T <sub>j</sub> = -40°C to 150°C	-27		25	%

Table 9. Current sense (8 V < V<sub>CC</sub> < 36 V) (continued)

Symbol	Parameter	Test conditions	Min.	Typ.	Max.	Unit
I <sub>SENSE0</sub>	Analog sense leakage current	I <sub>OUT</sub> = 0 A; V <sub>SENSE</sub> = 0 V; V <sub>IN</sub> = 0 V; T <sub>j</sub> = -40°C to 150°C	0		1	μA
		I <sub>OUT</sub> = 0 A; V <sub>SENSE</sub> = 0 V; V <sub>IN</sub> = 5 V; T <sub>j</sub> = -40°C to 150°C	0		2	
V <sub>SENSE</sub>	Max analog sense output voltage	I <sub>OUT</sub> = 40 A; R <sub>SENSE</sub> = 3.9 KΩ	5			V
V <sub>SENSEH</sub>	Analog sense output voltage in fault condition <sup>(2)</sup>	V <sub>CC</sub> = 24 V; R <sub>SENSE</sub> = 3.9 KΩ		8		V
I <sub>SENSEH</sub>	Analog sense output current in fault condition <sup>(2)</sup>	V <sub>CC</sub> = 24 V; V <sub>SENSE</sub> = 5 V		9	12	mA
t <sub>DSENSE2H</sub>	Delay response time from rising edge of IN pin	V <sub>SENSE</sub> < 4 V; 1 A < I <sub>OUT</sub> < 40 A; I <sub>SENSE</sub> = 90% of I <sub>SENSEMAX</sub> (see <a href="#">Figure 7</a> )		300	600	μs
Δt <sub>DSENSE2H</sub>	Delay response time between rising edge of output current and rising edge of current sense	V <sub>SENSE</sub> < 4 V; I <sub>SENSE</sub> = 90% of I <sub>SENSEMAX</sub> , I <sub>OUT</sub> = 90% of I <sub>OUTMAX</sub> I <sub>OUTMAX</sub> = 10 A (see <a href="#">Figure 10</a> )			450	μs
t <sub>DSENSE2L</sub>	Delay response time from falling edge of IN pin	V <sub>SENSE</sub> < 4 V; 1 A < I <sub>OUT</sub> < 40 A; I <sub>SENSE</sub> = 10 % of I <sub>SENSEMAX</sub> (see <a href="#">Figure 7</a> )		5	20	μs

- Parameter guaranteed by design; it is not tested.
- Fault condition includes: power limitation, overtemperature and open-load in OFF-state condition.

Table 10. Open-load detection (FR\_Stby = 5 V)

Symbol	Parameter	Test conditions	Min.	Typ.	Max.	Unit
V <sub>OL</sub>	Open-load Off-state voltage detection threshold	V <sub>IN</sub> = 0 V; 8 V < V <sub>CC</sub> < 36 V	2		4	V
t <sub>DSTKON</sub>	Output short-circuit to V <sub>CC</sub> detection delay at turn-off	See <a href="#">Figure 8</a>	180		1800	μs
I <sub>L(off2)</sub>	Off-state output current at V <sub>OUT</sub> = 4 V	V <sub>IN</sub> = 0 V; V <sub>SENSE</sub> = 0 V; V <sub>OUT</sub> rising from 0 V to 4 V	-120		0	μA

Table 10. Open-load detection (FR\_Stby = 5 V) (continued)

Symbol	Parameter	Test conditions	Min.	Typ.	Max.	Unit
$t_{d\_vol}$	Delay response from output rising edge to $V_{SENSE}$ rising edge in open-load	$V_{OUT} = 4\text{ V}$ ; $V_{IN} = 0\text{ V}$ ; $V_{SENSE} = 90\%$ of $V_{SENSEH}$			20	$\mu\text{s}$
$t_{DFRSTK\_ON}$	Output short circuit to $V_{CC}$ detection delay at $FR_{STBY}$ activation	See Figure 6; Input <sub>1,2</sub> = low			50	$\mu\text{s}$

Figure 6. Output stuck to  $V_{CC}$  detection delay time at  $FR_{STBY}$  activation

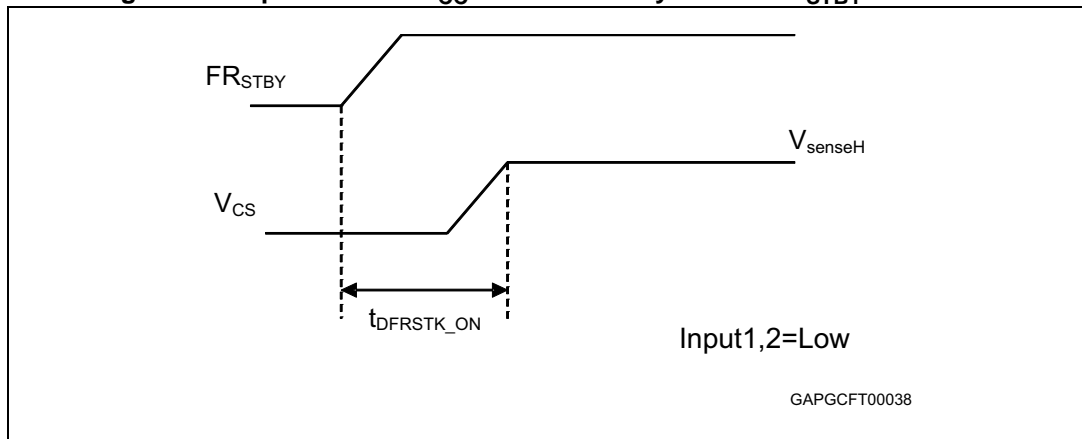


Figure 7. Current sense delay characteristics

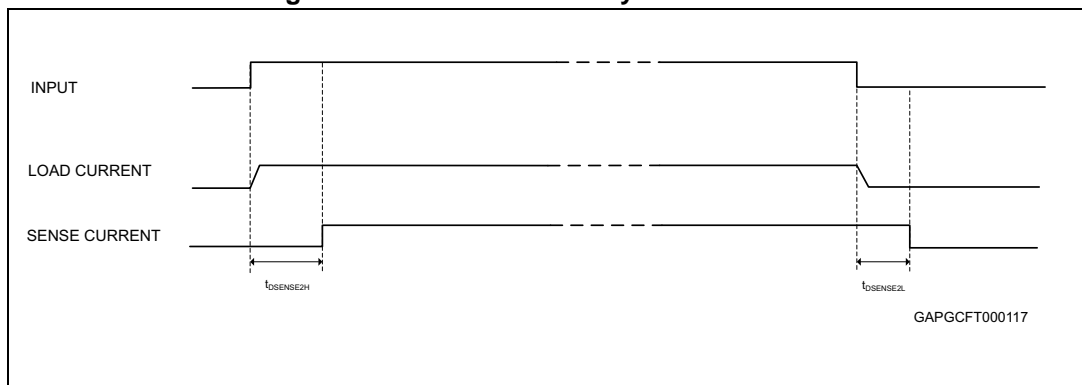


Figure 8. Open-load off-state delay timing

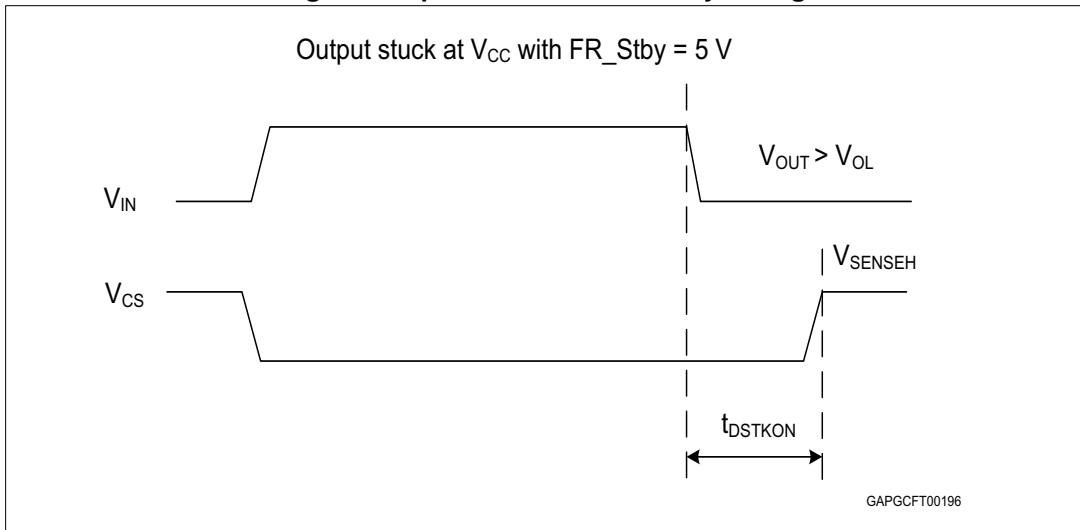


Figure 9. Switching characteristics

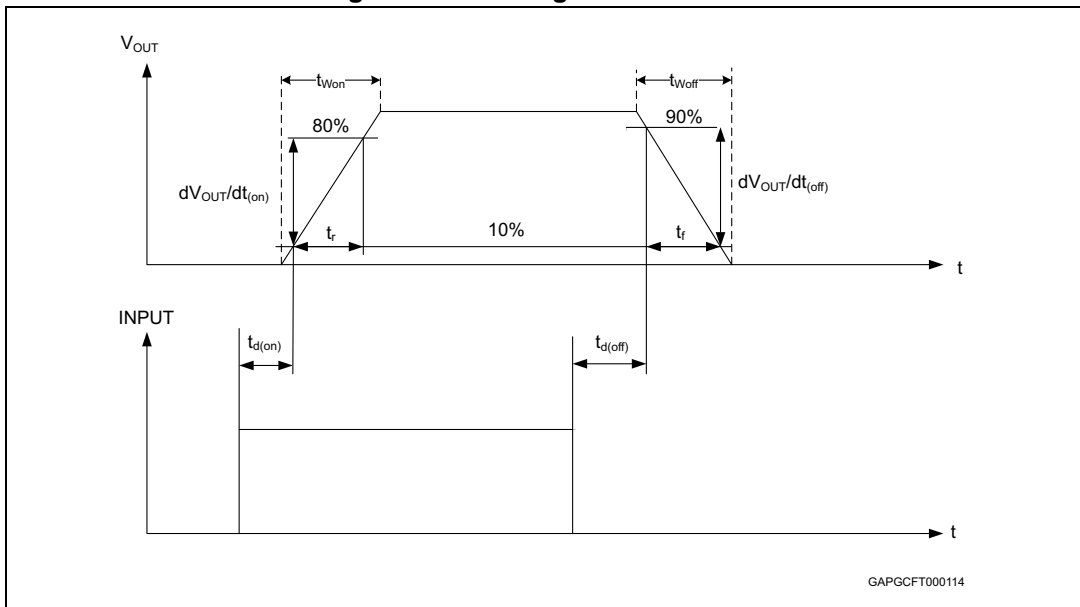


Figure 10. Delay response time between rising edge of output current and rising edge of current sense

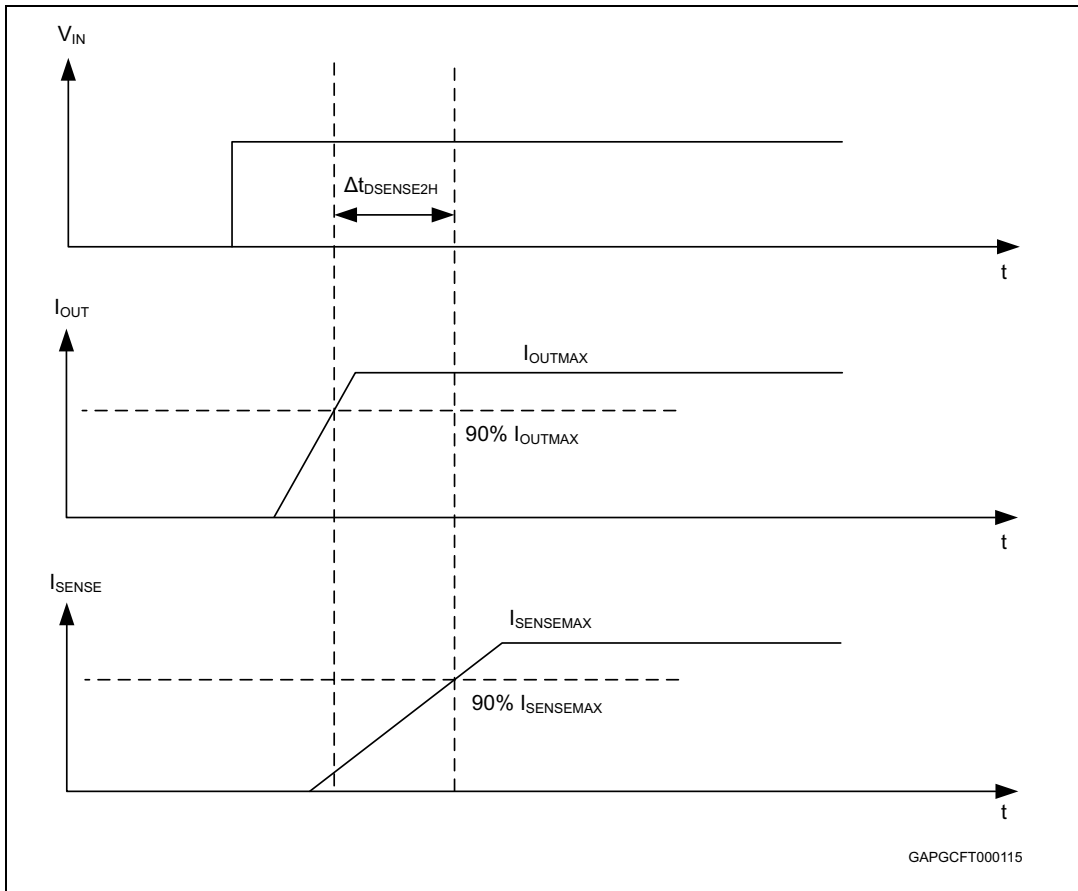


Figure 11. Output voltage drop limitation

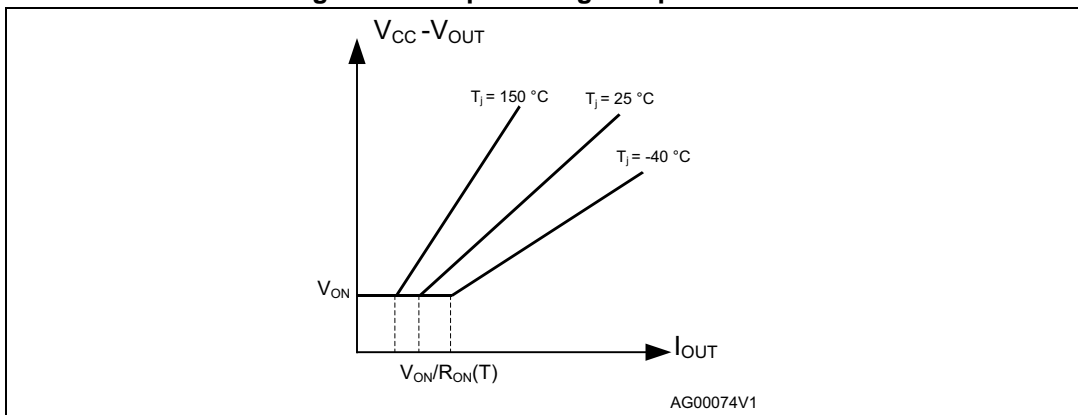




Figure 12. Device behavior in overload condition

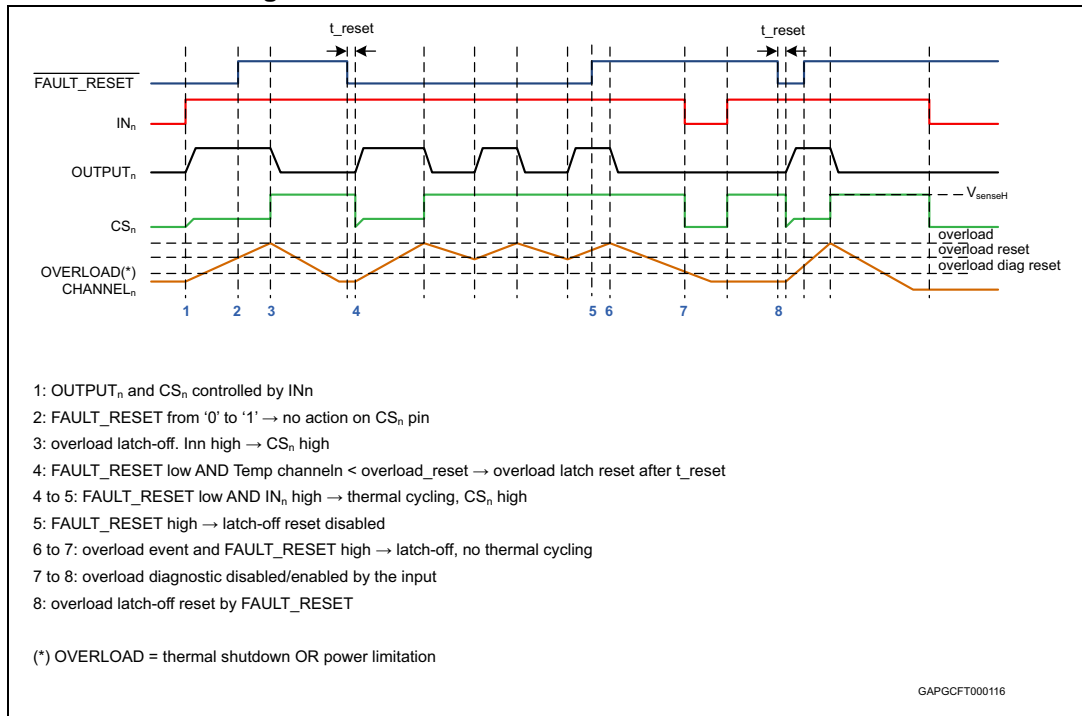


Table 11. Truth table

Conditions	Fault reset standby	Input	Output	Sense
Standby	L	L	X	0
Normal operation	X	L	L	0
	X	H	H	Nominal
Overload	X	L	L	0
	X	H	H	> Nominal
Overtemperature / short to ground	X	L	L	0
	L	H	Cycling	V <sub>SENSEH</sub>
	H	H	Latched	V <sub>SENSEH</sub>
Undervoltage	X	X	L	0
Short to V <sub>BAT</sub>	L	L	H	0
	H	L	H	V <sub>SENSEH</sub>
	X	H	H	< Nominal
Open-load Off-state (with pull-up)	L	L	H	0
	H	L	H	V <sub>SENSEH</sub>
	X	H	H	0
Negative output voltage clamp	X	L	Negative	0

**Table 12. Electrical transient requirements (part 1)**

ISO 7637-2: 2004(E) Test pulse	Test levels <sup>(1)</sup>		Number of pulses or test times	Burst cycle/pulse repetition time		Delays and impedance
	III	IV				
1	- 450 V	- 600 V	5000 pulses	0.5 s	5 s	1 ms, 50 Ω
2a	+ 37 V	+ 50 V	5000 pulses	0.2 s	5 s	50 μs, 2 Ω
3a	- 150 V	- 200 V	1h	90 ms	100 ms	0.1 μs, 50 Ω
3b	+ 150 V	+ 200 V	1h	90 ms	100 ms	0.1 μs, 50 Ω
4	- 12 V	- 16 V	1 pulse			100 ms, 0.01 Ω
5b <sup>(2)</sup>	+ 123 V	+ 174 V	1 pulse			350 ms, 1 Ω

1. The above test levels must be considered referred to  $V_{CC} = 24.5V$  except for pulse 5b
2. Valid in case of external load dump clamp: 58V maximum referred to ground.

**Table 13. Electrical transient requirements (part 2)**

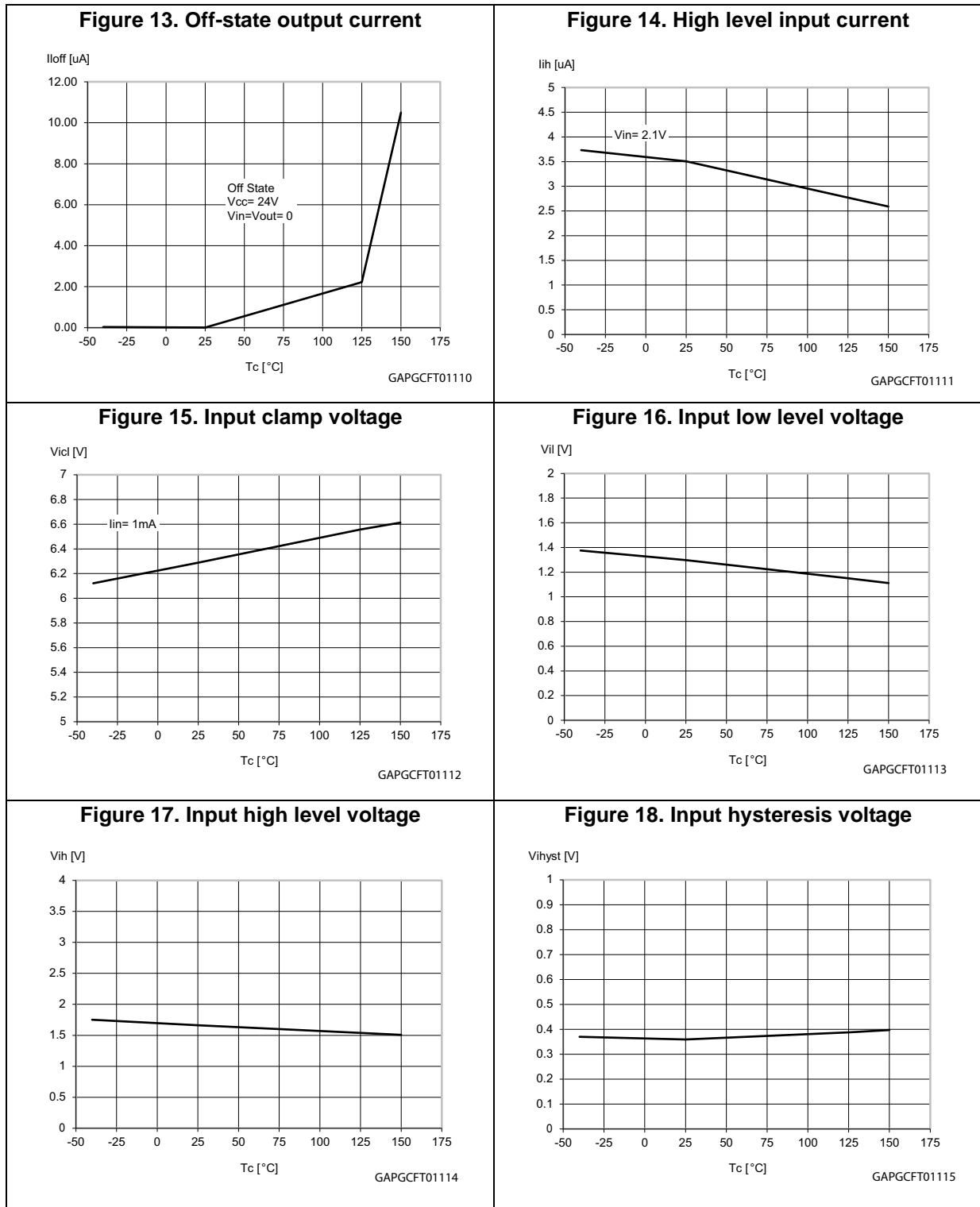
ISO 7637-2: 2004(E) Test pulse	Test level results	
	III	IV
1	C	C <sup>(1)</sup>
2a	C	C
3a	C	C
3b <sup>(2)</sup>	E	E
3b <sup>(3)</sup>	C	C
4	C	C
5b <sup>(4)</sup>	C	C

1. With  $R_{LOAD} < 24 \Omega$ .
2. Without capacitor between  $V_{CC}$  and GND.
3. With 10 nF between  $V_{CC}$  and GND.
4. External load dump clamp: 58 V maximum, referred to ground.

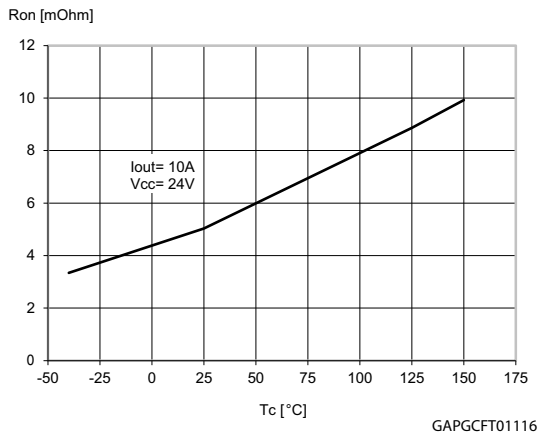
**Table 14. Electrical transient requirements (part 3)**

Class	Contents
C	All functions of the device are performed as designed after exposure to disturbance.
E	One or more functions of the device are not performed as designed after exposure to disturbance and cannot be returned to proper operation without replacing the device.

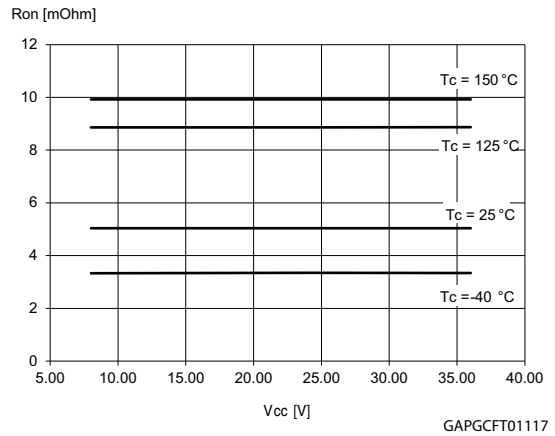
## 2.4 Electrical characteristics curves



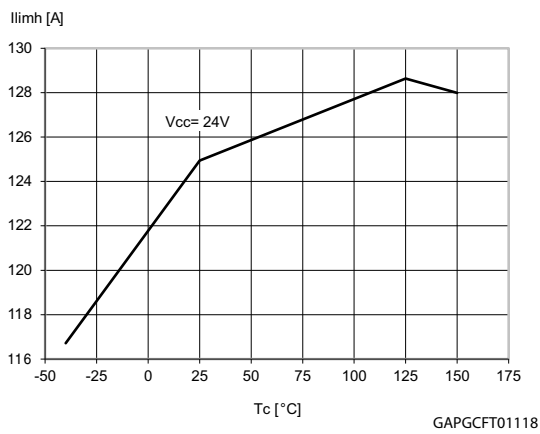
**Figure 19. On state resistance vs  $T_{case}$**



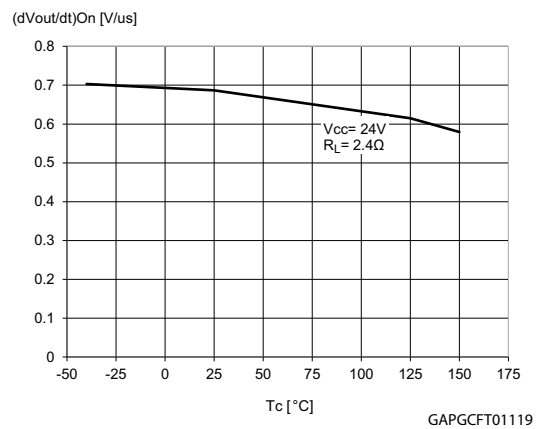
**Figure 20. On state resistance vs  $V_{CC}$**



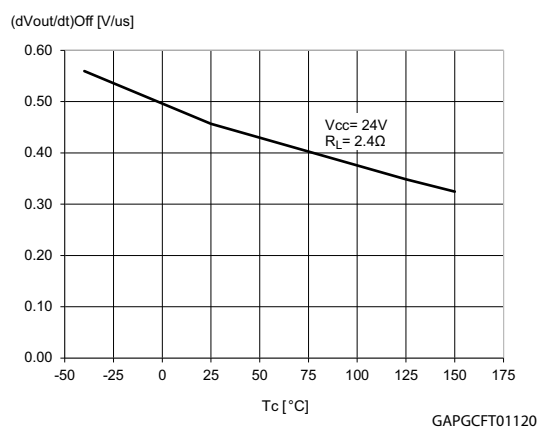
**Figure 21.  $I_{LIMH}$  vs  $T_{case}$**



**Figure 22. Turn-On voltage slope**

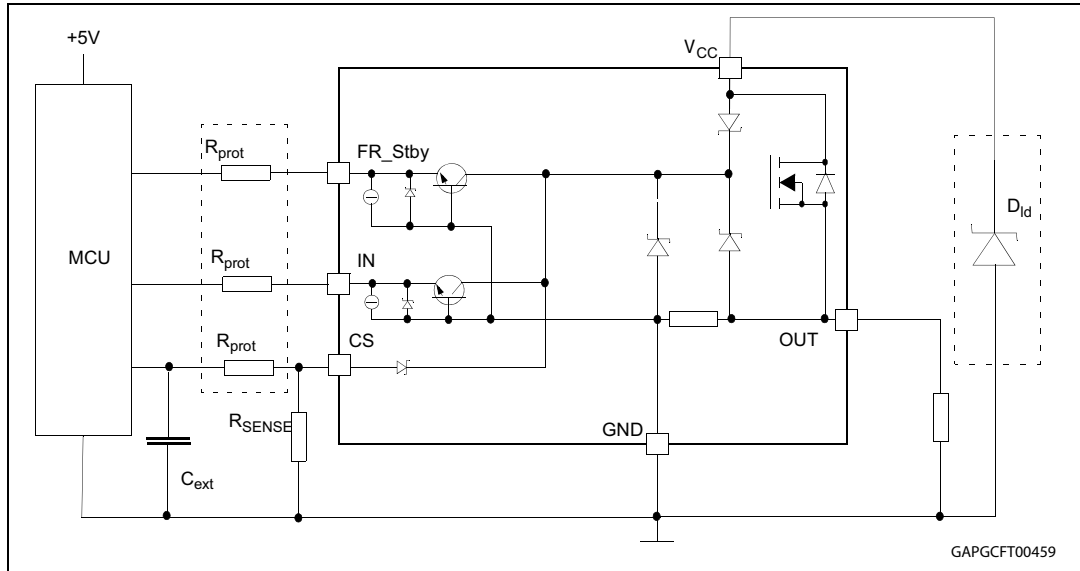


**Figure 23. Turn-Off voltage slope**



### 3 Application information

Figure 24. Application schematic



#### 3.1 Load dump protection

D<sub>id</sub> is necessary (voltage transient suppressor) if the load dump peak voltage exceeds the V<sub>CC</sub> max DC rating. The same applies if the device is subject to transients on the V<sub>CC</sub> line that are greater than the ones shown in the ISO 7637-2 2004 (E) table.

#### 3.2 MCU I/Os protection

When negative transients are present on the V<sub>CC</sub> line, the control pins is pulled negative. ST suggests to insert a resistor (R<sub>prot</sub>) in line to prevent the microcontroller I/O pins from latching-up.

The value of these resistors is a compromise between the leakage current of microcontroller and the current required by the HSD I/Os (input levels compatibility) with the latch-up limit of microcontroller I/Os.

##### Equation 1

$$-V_{CCpeak} / I_{latchup} \leq R_{prot} \leq (V_{OH\mu C} - V_{IH}) / I_{IHmax}$$

Calculation example:

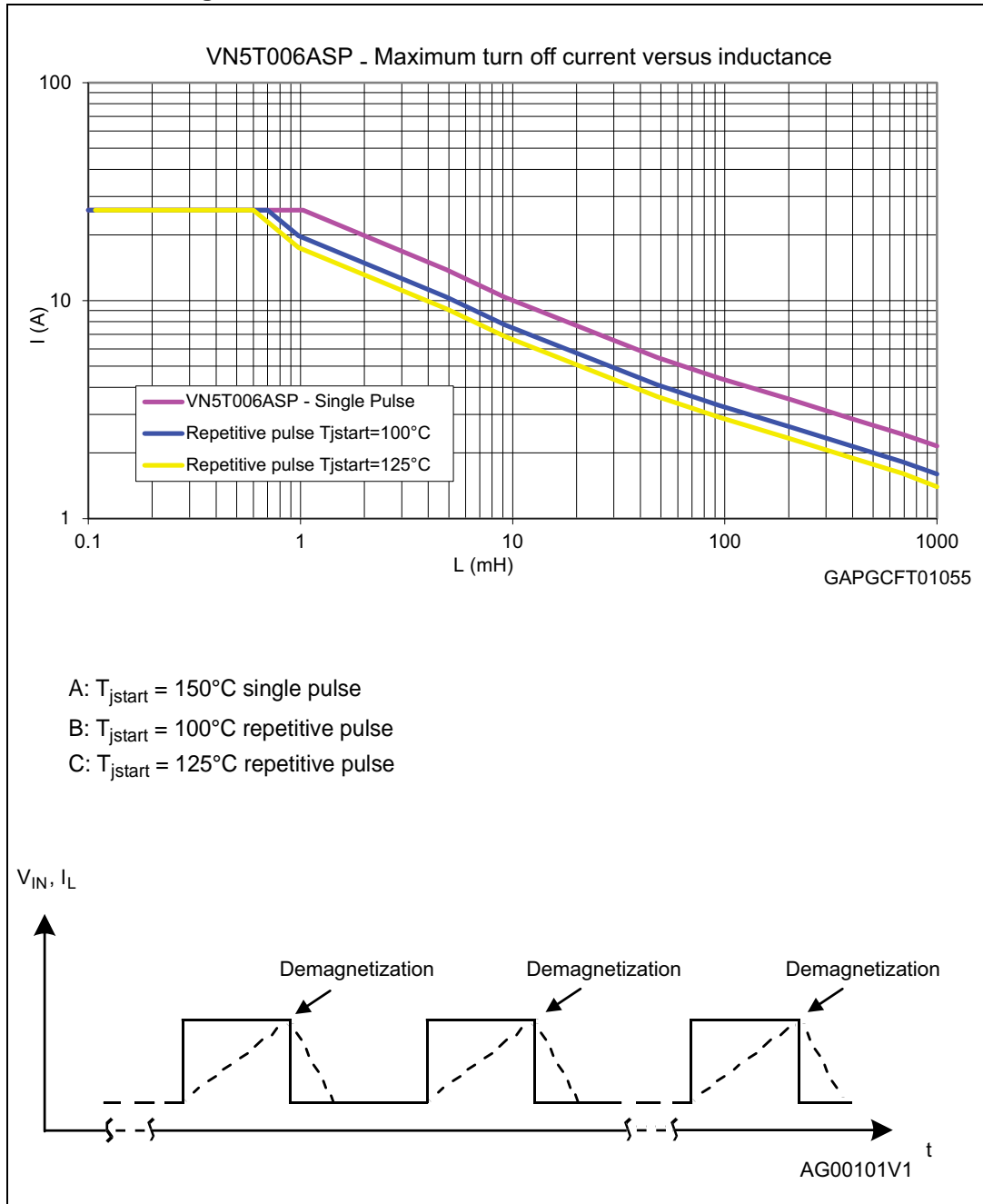
For V<sub>CCpeak</sub> = -600 V and I<sub>latchup</sub> ≥ 20 mA; V<sub>OHμC</sub> ≥ 4.5 V

30 kΩ ≤ R<sub>prot</sub> ≤ 190 kΩ.

Recommended value: R<sub>prot</sub> = 56 kΩ

### 3.3 Maximum demagnetization energy ( $V_{CC} = 24\text{ V}$ )

Figure 25. Maximum turn-off current versus inductance

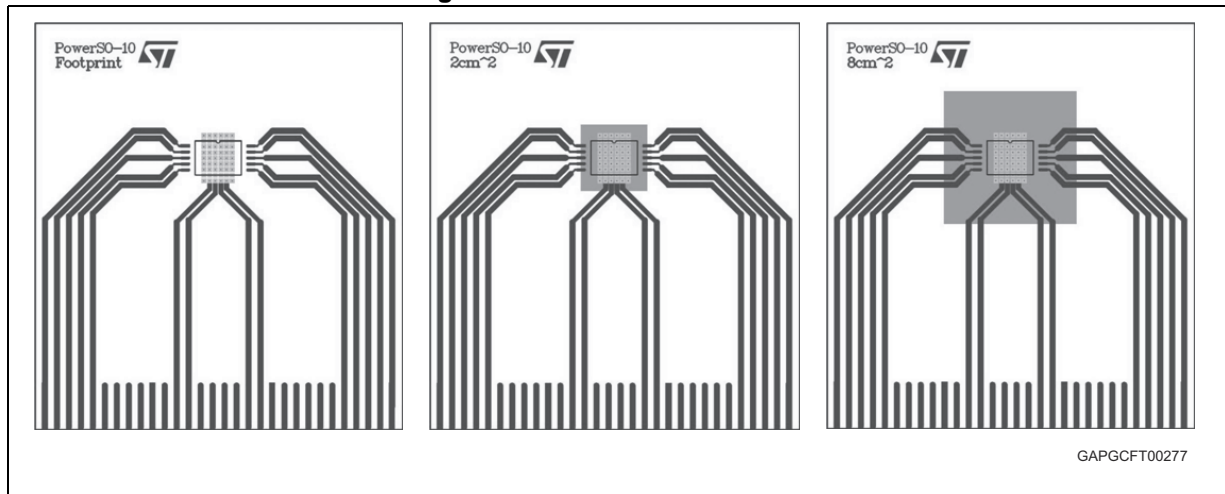


Note: Values are generated with  $R_L = 0\ \Omega$ .  
 In case of repetitive pulses,  $T_{jstart}$  (at the beginning of each demagnetization) of every pulse must not exceed the temperature specified above for curves A and B.

## 4 Package and PCB thermal data

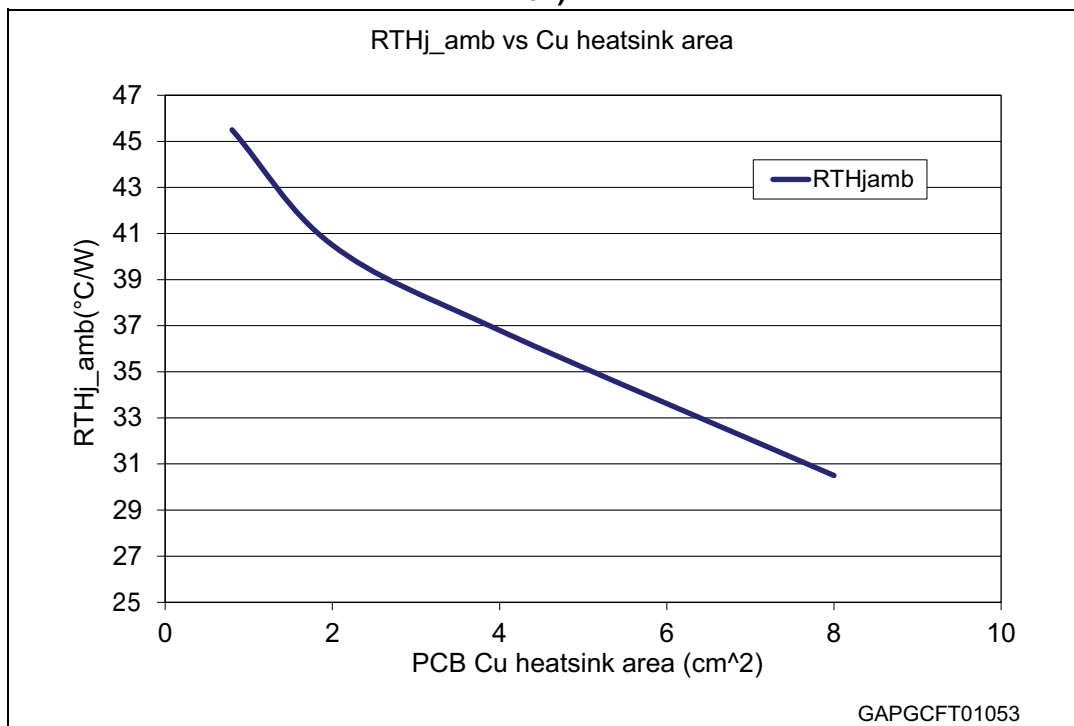
### 4.1 PowerSO-10 thermal data

Figure 26. PowerSO-10 PC board

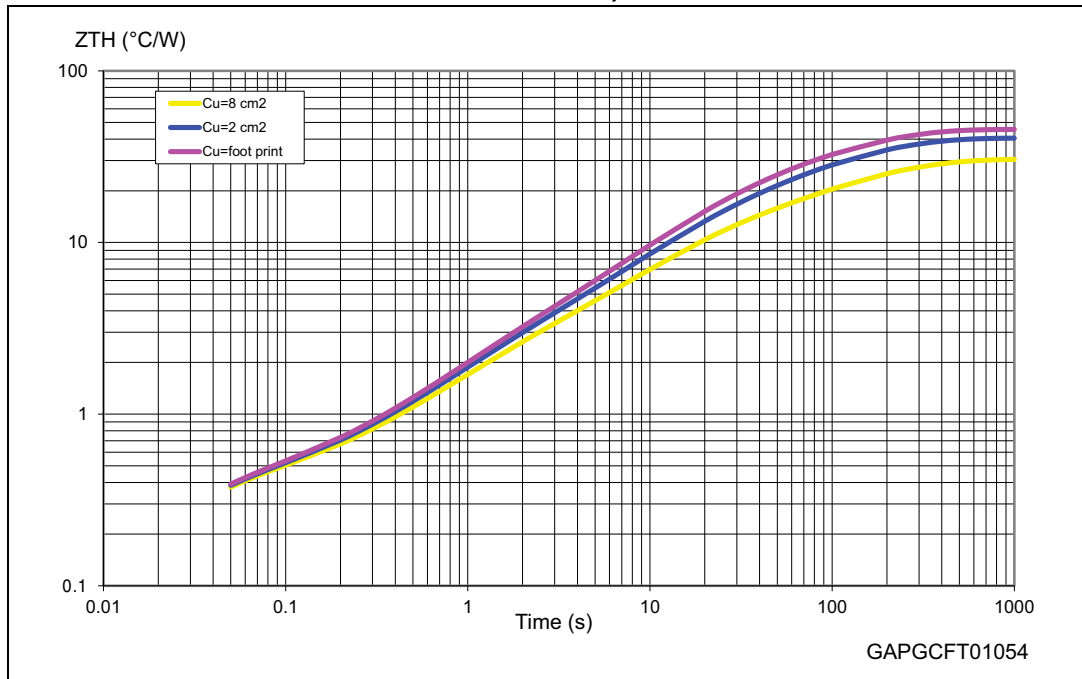


1. Layout condition of  $R_{th}$  and  $Z_{th}$  measurements (Board finish thickness 1.6 mm +/- 10%; Board double layer; Board dimension 77 x 86; Board Material FR4; Cu thickness 0.070 mm (front and back side); Thermal vias separation 1.2 mm; Thermal via diameter 0.3 mm +/- 0.08 mm; Cu thickness on vias 0.025 mm).

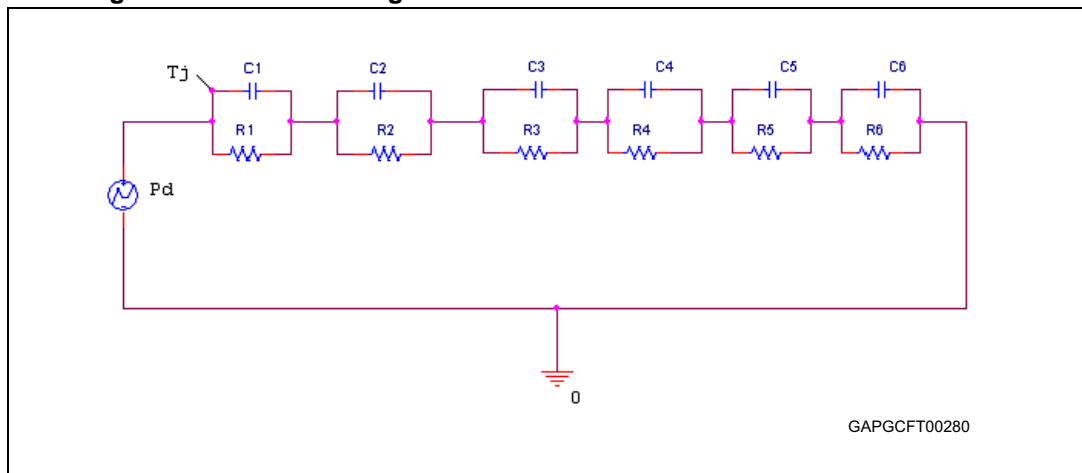
Figure 27.  $R_{thj-amb}$  vs PCB copper area in open box free air condition (one channel on)



**Figure 28. PowerSO-10 thermal impedance junction ambient single pulse (one channel on)**



**Figure 29. Thermal fitting model of a double channel HSD in PowerSO-10**



1. The fitting model is a simplified thermal tool and is valid for transient evolutions where the embedded protections (power limitation or thermal cycling during thermal shutdown) are not triggered.

**Equation 2: pulse calculation formula**

$$Z_{TH\delta} = R_{TH} \cdot \delta + Z_{THtp}(1 - \delta)$$

where  $\delta = t_p/T$



Table 15. Thermal parameters

Area/island (cm <sup>2</sup> )	Footprint	2	8
R1 (°C/W)	0.05		
R2 (°C/W)	0.3		
R3 (°C/W)	1.2		
R4 (°C/W)	7		
R5 (°C/W)	13	12	8
R6 (°C/W)	24	20	14
C1 (W.s/°C)	0.05		
C2 (W.s/°C)	0.1		
C3 (W.s/°C)	1		
C4 (W.s/°C)	2		
C5 (W.s/°C)	3	4	8
C6 (W.s/°C)	6	8	14

## 5 Package information

### 5.1 ECOPACK<sup>®</sup>

In order to meet environmental requirements, ST offers these devices in different grades of ECOPACK<sup>®</sup> packages, depending on their level of environmental compliance. ECOPACK<sup>®</sup> specifications, grade definitions and product status are available at: [www.st.com](http://www.st.com). ECOPACK<sup>®</sup> is an ST trademark.

### 5.2 PowerSO-10 mechanical data

Figure 30. PowerSO-10 package dimensions

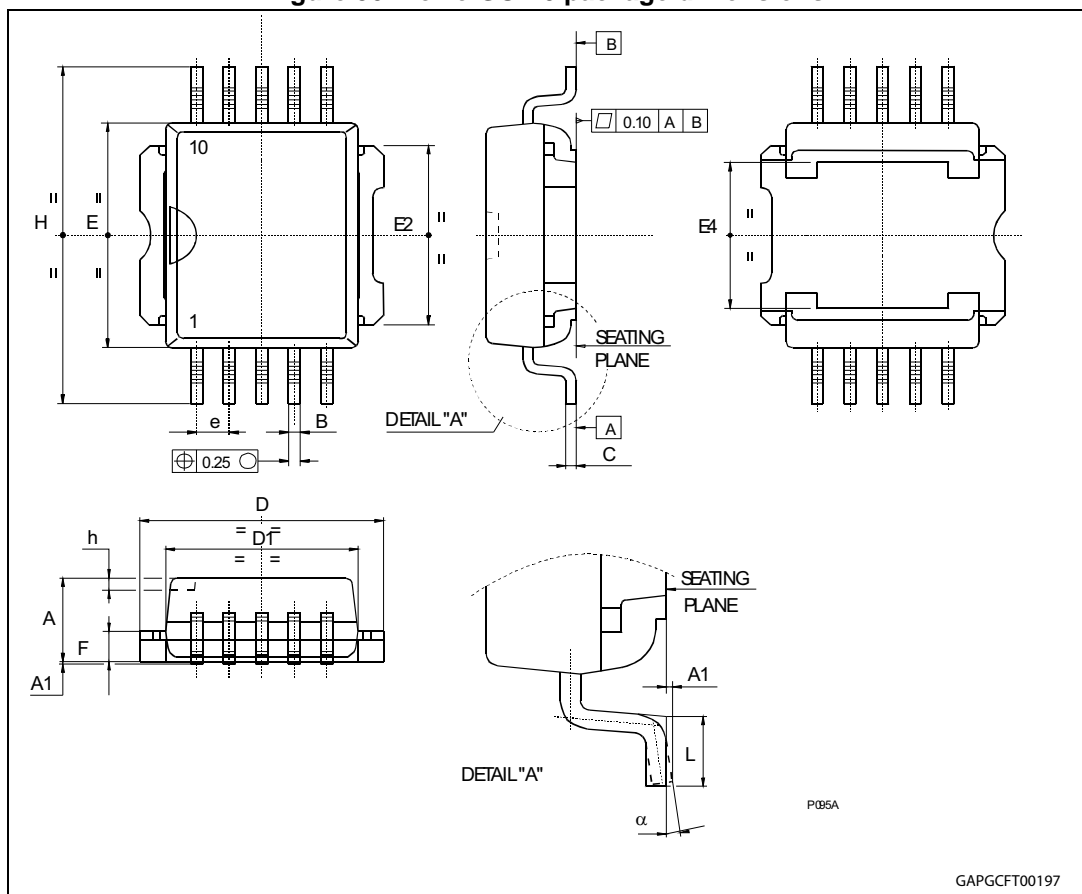


Table 16. PowerSO-10 mechanical data

Symbol	Millimeters		
	Min.	Typ.	Max.
A	3.35		3.65
A <sup>(1)</sup>	3.4		3.6
A1	0.00		0.10
B	0.40		0.60
B <sup>(1)</sup>	0.37		0.53
C	0.35		0.55
C <sup>(1)</sup>	0.23		0.32
D	9.40		9.60
D1	7.40		7.60
E	9.30		9.50
E2	7.20		7.60
E2 <sup>(1)</sup>	7.30		7.50
E4	5.90		6.10
E4 <sup>(1)</sup>	5.90		6.30
e		1.27	
F	1.25		1.35
F <sup>(1)</sup>	1.20		1.40
H	13.80		14.40
H <sup>(1)</sup>	13.85		14.35
h		0.50	
L	1.20		1.80
L <sup>(1)</sup>	0.80		1.10
a	0°		8°
α <sup>(1)</sup>	2°		8°

1. Muar only POA P013P.

### 5.3 Packing information

Figure 31. PowerSO-10 suggested pad layout and tube shipment (no suffix)

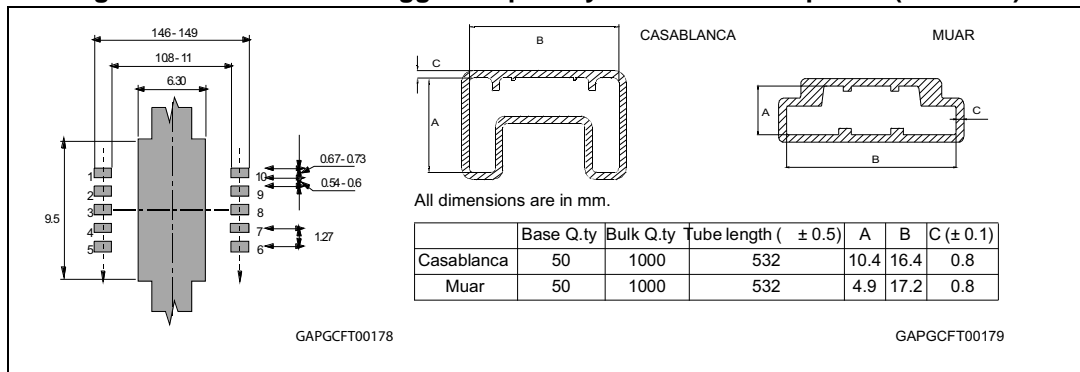
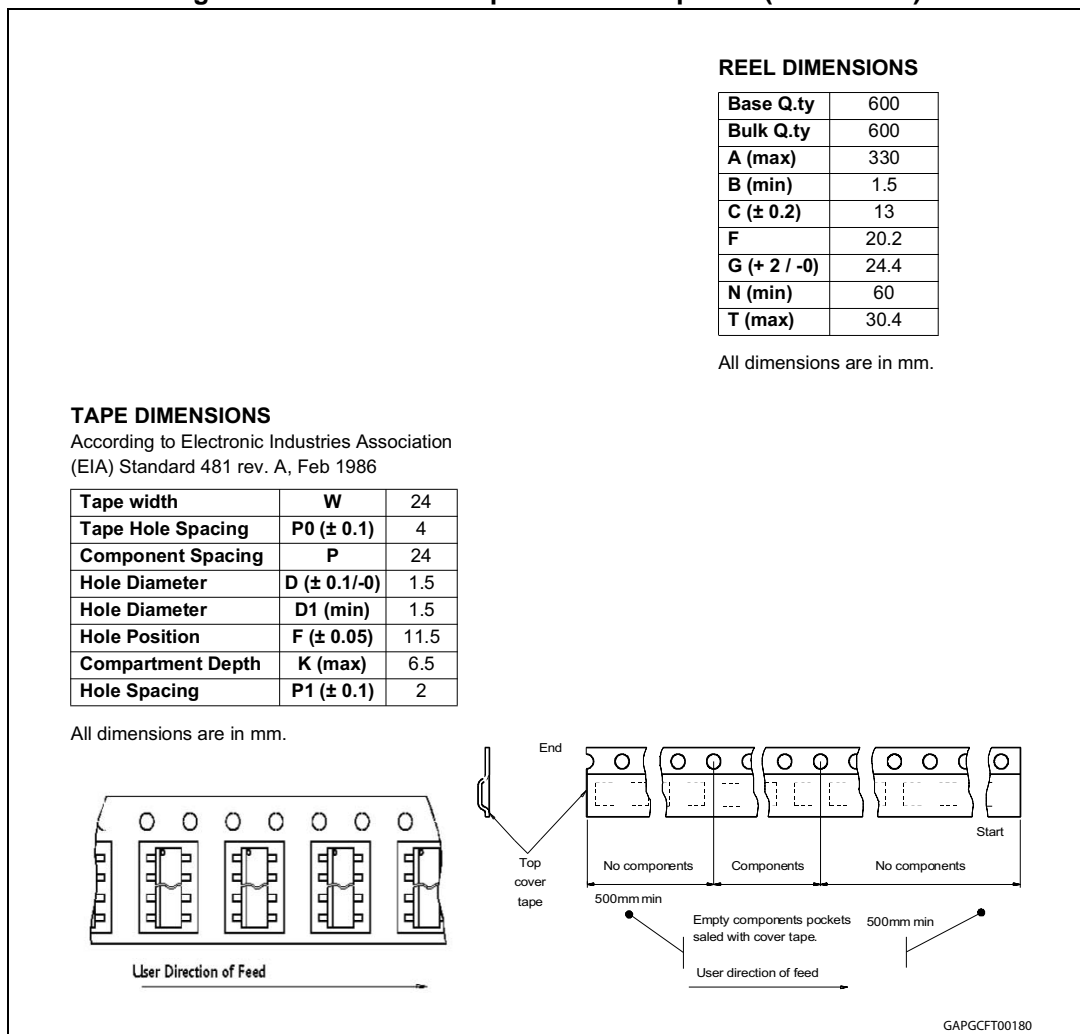


Figure 32. PowerSO-10 tape and reel shipment (suffix “TR”)



## 6 Order codes

Table 17. Device summary

Package	Order codes	
	Tube	Tape and reel
PowerSO-10	VN5T006ASP-E	VN5T006ASPTR-E

## 7 Revision history

**Table 18. Document revision history**

Date	Revision	Changes
19-Dec-2012	1	Initial release.
16-Jan-2013	2	Updated <a href="#">Figure 3: Current and voltage conventions</a> <a href="#">Table 6: Switching (<math>V_{CC} = 24\text{ V}</math>; <math>T_j = 25^\circ\text{C}</math>)</a> : – $dV_{OUT}/dt_{(on)}$ : updated values <a href="#">Table 9: Current sense (<math>8\text{ V} &lt; V_{CC} &lt; 36\text{ V}</math>)</a> : – $I_{OL}$ : removed row – $dK/K_{BULB2}$ : updated test conditions Updated <a href="#">Table 22: Turn-On voltage slope</a> and <a href="#">Table 23: Turn-Off voltage slope</a>
16-Jun-2013	3	Changed document status from “preliminary data” to “production data”
17-Sep-2013	4	Updated disclaimer.
11-Apr-2016	5	Added AEC-Q101 qualified in <a href="#">Features</a> section <a href="#">Table 9: Current sense (<math>8\text{ V} &lt; V_{CC} &lt; 36\text{ V}</math>)</a> : – $dK_6/K_6$ : updated test conditions

**IMPORTANT NOTICE – PLEASE READ CAREFULLY**

STMicroelectronics NV and its subsidiaries ("ST") reserve the right to make changes, corrections, enhancements, modifications, and improvements to ST products and/or to this document at any time without notice. Purchasers should obtain the latest relevant information on ST products before placing orders. ST products are sold pursuant to ST's terms and conditions of sale in place at the time of order acknowledgement.

Purchasers are solely responsible for the choice, selection, and use of ST products and ST assumes no liability for application assistance or the design of Purchasers' products.

No license, express or implied, to any intellectual property right is granted by ST herein.

Resale of ST products with provisions different from the information set forth herein shall void any warranty granted by ST for such product.

ST and the ST logo are trademarks of ST. All other product or service names are the property of their respective owners.

Information in this document supersedes and replaces information previously supplied in any prior versions of this document.

© 2016 STMicroelectronics – All rights reserved

# Mouser Electronics

Authorized Distributor

Click to View Pricing, Inventory, Delivery & Lifecycle Information:

[STMicroelectronics:](#)

[VN5T006ASPTR-E](#)