

26M048B

Ø 26 mm • RoHS Compliant • 10.6 mNm

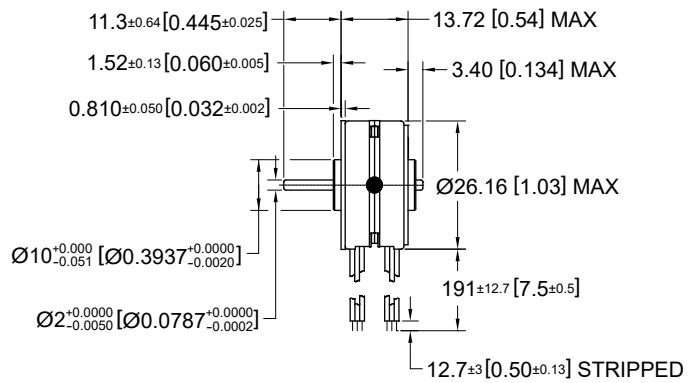
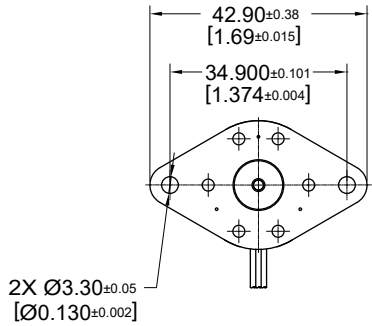

Dimensions in mm. [inches]

Electrical Data	26M048B••				Unit
	1U Unipolar	2U Unipolar	1B Bipolar	2B Bipolar	
1 Operating Voltage	5	12	5	12	VDC
2 Resistance per Phase, ± 10%	19.6	110.0	19.8	108.0	Ohms
3 Inductance per Phase, typ	5.3	36.5	13.0	60.7	mH
4 Rated Current per Phase *	0.26	0.11	0.25	0.11	A
Coil Independent Parameters					
5 Holding Torque, MIN *	9.2 (1.3)	9.2 (1.3)	10.6 (1.5)	10.6 (1.5)	mNm (oz-in)
6 Detent Torque, Max		0.85 (0.12)			mNm (oz-in)
7 Rotor Inertia		1.1 (0.00601)			gcm ² (oz-in ²)
8 Step Angle		7.5			Degree
9 Absolute accuracy 2 ph. On, Full step		± 0.5			Degree
10 Steps per Revolution		48.0			
11 Ambient Temp Range (operating)		-20 to +70 (-4 to +158)			°C (°F)
12 Maximum Coil Temperature		130 (266)			°C (°F)
13 Bearing Type		Sintered Bronze Sleeve			
14 Insulation Resistance at 500 VDC		100.0			Mohms
15 Dielectric Withstanding Voltage		650 VRMS for 2 seconds			VAC
16 Weight		34 (1.2)			g (oz)
17 Leadwire		AWG #28, UL1429 (80° C, 150 V)			

Note: All motor data values at 20° C unless otherwise specified

* Energize at rated current, 2-Phase On

