

APPLICABLE STANDARD					
RATING	Operating temperature range.	—°C to —°C	Storage temperature range.	—°C to —°C	
	_____	_____	_____	_____	
	_____	_____	_____	_____	
SPECIFICATIONS					
ITEM	TEST METHOD	REQUIREMENTS	QT	AT	
CONSTRUCTION					
General examination.	Visually and by measuring instrument.	According to drawing.	X	X	
Marking	Confirmed visually		X	X	
ENVIRONMENTAL CHARACTERISTICS					
Corrosion salt mist	Exposed in 5 % salt water spray for 48 h.	No heavy corrosion ruin the function.	X	—	
	COUNT	DESCRIPTION OF REVISIONS	DESIGNED	CHECKED	DATE
A					
REMARK			APPROVED	EJ.KUNII	15.09.29
			CHECKED	EJ.KUNII	15.09.29
			DESIGNED	TP.KOMATSU	15.09.29
			DRAWN	TP.KOMATSU	15.09.29
Unless otherwise specified, refer to IEC 60512.					
Note QT:Qualification Test AT:Assurance Test X:Applicable Test			DRAWING NO.		ELC-115792-00-00
HRS	SPECIFICATION SHEET		PART NO.	HR10A-7R-N	
	HIROSE ELECTRIC CO., LTD.		CODE NO.	CL110-0951-8-00	▲ 1/1

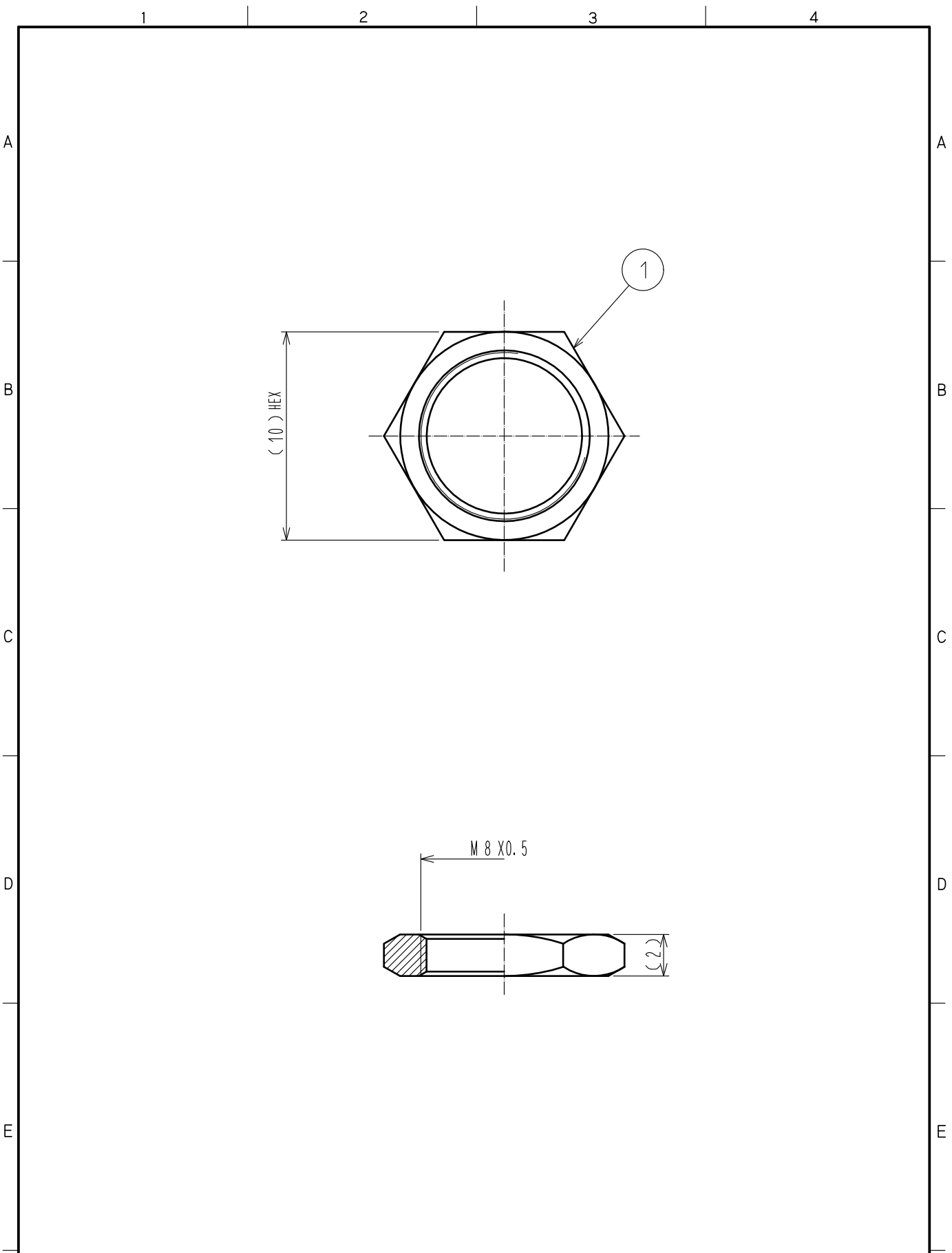

1	Brass	Nickel plating (100 pcs./bag)				
NO.	MATERIAL	FINISH . REMARKS	NO.	MATERIAL	FINISH . REMARKS	
UNITS mm		SCALE 4 : 1	COUNT 	DESCRIPTION OF REVISIONS		DESIGNED
HIROSE ELECTRIC CO., LTD.		APPROVED : EJ. KUNII	15.09.29	DRAWING NO.		EDC-115792-00-00
		CHECKED : EJ. KUNII	15.09.29	PART NO.		HR10A-7R-N
		DESIGNED : TP. KOMATSU	15.09.29	CODE NO.		CL110-0951-8-00
		DRAWN : TP. KOMATSU	15.09.29			1/1

Mouser Electronics

Authorized Distributor

Click to View Pricing, Inventory, Delivery & Lifecycle Information:

[Hirose Electric:](#)

[HR10A-7R-N](#)