

Products Crimped	Corresponding Die Set Instruction Sheet
AMPOWER* Terminals and Splices, 6 - 3/0 AWG	408-8703
SOLISTRAND* Terminals and Splices, 8 - 4/0 AWG	408-8691
TERMINYL* Terminals and Splices, 8 - 4 AWG	408-8704

Figure 1

1. INTRODUCTION

This instruction sheet covers application, inspection and maintenance procedures for the 12 ton Titanium Crimping Head 1490747-1 (see Figure 1). This crimping head uses interchangeable crimping dies and is used to crimp the products listed in the table above.

Note: This instruction sheet provides general information for the insertion of dies and the crimping procedure. Always refer to the instructions packaged with specific die sets for specific crimping instructions and for compatible products, wire ranges, strip dimensions, and application procedures.

This crimping head is designed for use with Foot Hydraulic Pump PN 1583659-1, Hand Hydraulic Pump PN 1583661-1, or Electric Hydraulic Pumps; PN 1804700-1 (115 VAC) and PN 1804700-2 (220 VAC).

Warning: To avoid personal injury and potential damage to the crimp head, TE Connectivity (TE) requires the crimp head to operate at 9,800 to 10,200 PSI [676 to 703 bar]. TE recommends using 10,000 PSI [689 bar] TE Hydraulic Pumps as other manufacturers' pumps may apply insufficient pressure (resulting in an inadequate crimp) or excessive pressure (resulting in failure of the head). Additionally, the TE pump must be used to maintain CE certification; if using other manufacturers' pumps, the user is responsible for self-certification.



NOTE

Dimensions in this instruction sheet are in millimeters [with inches in brackets]. Illustrations and figures are for reference only and are not drawn to scale.

Reasons for reissue of this Instruction Sheet are provided in Section 8; REVISION SUMMARY

2. DESCRIPTION

Main components of the crimping head are: a “C” Head which houses the stationary die, the upper and lower die release buttons which release the dies, a cylinder which contains the head’s hydraulic chamber, a piston (ram) which holds and controls the moving die, and a quick connect/disconnect coupler (cylinder half) which mates with the coupler on the hose or handle control to release or supply pressure. A dust cap covers the quick-disconnect coupling.



DANGER

To avoid injury when using hydraulic crimping equipment, observe the following precautions:

- DO NOT modify the crimping equipment in any way.
- USE ONLY dies, terminals, splices, and wire specified for the head.
- DO NOT perform repairs other than those specified in the instructional material supplied with the equipment.

3. CRIMPING HEAD INSTALLATION

Each crimping head is shipped with a coating of lubricating oil to prevent rust and corrosion. Wipe the oil off before installing the crimping head on the power unit. Note that the crimping head is shipped without oil inside the cylinder.



CAUTION

Prior to installing the head, verify that the pump and hose being used are working properly, and are adjusted to and rated at 10,000 psi. An incorrectly adjusted or rated pump/hose could result in severe tooling damage, as well as personal injury.



DANGER

Verify that hydraulic pressure to the hose or handle control is released and that power supply is disconnected from electric power unit, if applicable.

To install crimping head, proceed as follows:

1. Thoroughly clean coupling area of handle control or hose assembly and crimping head (see Figure 1).
2. Remove protective dust caps from both quick connect/disconnect couplers.
3. Hold hose or handle control in vertical position to prevent oil spillage. Attach hose or handle control to coupling section on head. **THREAD PROPERLY AND TIGHTEN SECURELY.**



CAUTION

Oil flow must be unobstructed between power unit and crimping head. Verify that all couplers are fully mated and tightened.



NOTE

If crimping head must be removed after being in production, pressure must be released in the hydraulic system beforehand.

- If using Electric Hydraulic Pumps; PN 1804700-1 (115 VAC) and PN 1804700-2 (220 VAC), disconnect power unit from power supply.
- If using Foot Hydraulic Pump PN 1583659-1, or Hand Hydraulic Pump PN 1583661-1, depress pressure release lever.

4. DIE INSERTION AND REMOVAL (FIGURE 2)



DANGER

Use extreme care when operating power unit. DO NOT inadvertently actuate the tool when installing or changing dies. Personal injury could result.

Install and remove dies in accordance with the Instruction Sheet packaged with each die set.

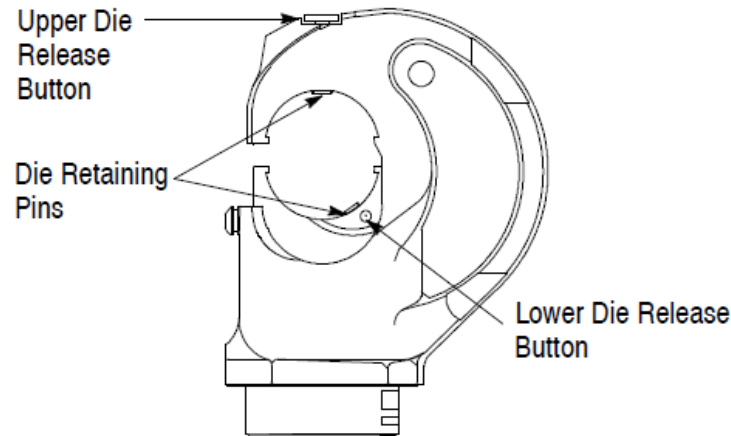

Figure 2

5. CRIMPING PROCEDURE

The following crimping procedure provides general information. Refer to instructions packaged with individual die sets for specific products, wire sizes, strip dimensions, positioning of terminals and splices in the dies, and crimping procedures.



DANGER

To prevent personal injury when operating the power unit, exercise caution while holding terminals, splices or wire near crimping area.



CAUTION

NEVER operate the power unit without having a crimping head attached to the handle control or crimping head coupling and, NEVER operate the head without crimping dies installed in it.

1. Insert terminal or splice in the stationary (upper) die in accordance with instructions packaged with the dies.
2. Slowly advance moving (lower) die with short, quick strokes until terminal or splice is secure.
3. Insert the stripped wire.
4. Cycle tool to complete crimp and remove crimped terminal.



NOTE

If the terminal sticks in the die after crimping, apply a rocking action to release it.

6. INSPECTION AND MAINTENANCE



DANGER

Verify hydraulic pressure is released and power supply is disconnected before following maintenance and inspection procedures; unless otherwise specified in the procedure.

Each crimping head is assembled and inspected before shipment. TE Connectivity recommends that the crimping head be inspected immediately upon its arrival at the facility of use, and at regularly scheduled intervals, to ensure the head has not been damaged during handling and use. Frequency of inspection depends upon the following: care, amount of use, and handling of the head; type and size of products crimped; degree of operator skill; and environmental conditions.

6.1. Cleaning

Remove accumulations of dirt and grease on the crimping head; especially in areas where dies are installed and terminals and splices are crimped. Clean the entire head frequently with a clean, lint-free cloth.

6.2. Visual Inspection [FIGURE 3 and 4]

NOTE: Once per year, or every 7,500 cycles (whichever comes first), the hydraulic head should be returned to TE for magnetic particle inspection. Additionally, inspect and service the head (as detailed in Figure 3) every month or 1,000 cycles; whichever comes first.

Item To Be Inspected	Inspection / Problem	Solution
"C" Head	Inspect for cracks (see Figure 4), gouges, nicks or galling on the "C" Head or where the "C" Head contacts dies	Return Tool for Repair (See Section 7, REPLACE / REPAIR)
	Upper Die Retaining Pin Not Holding Stationary Die in Place	Return Tool for Repair (See Section 7, REPLACE / REPAIR)
	Upper Die Release Button Sticking (should move in/out easily under moderate pressure)	Return Tool for Repair (See Section 7, REPLACE / REPAIR)
Cylinder	Inspect for cracks (see Figure 4), gouges, nicks or galling	If cracks are found, return Tool for Repair (See Section 7, REPLACE / REPAIR) If gouges, nicks or galling are found, remove any sharp edges using a fine emery cloth
	Inspect for Oil Leaks Between the Cylinder and Coupling Coupling Sticking to the Cylinder (should turn on/off easily under moderate pressure with wrench)	Tighten or replace the coupling
Quick Disconnect Coupling	The coupling mates hard, won't mate or won't release, leaks oil, or sticks at the hose connection	Replace Coupling
Ram	Inspect ram in the Power "ON" (ram advanced) position for evidence of galling, cracks (see Figure 4), or oil leaks between the ram and cylinder	If cracks or leaks are found, return Tool for Repair (See Section 7, REPLACE / REPAIR) If galling is found, remove any sharp edges using a fine emery cloth
	Lower Die Retaining Pin Not Holding Moving Die in Place	Return Tool for Repair (See Section 7, REPLACE / REPAIR)
	Lower Die Release Button Sticking (should move in/out easily under moderate pressure)	Return Tool for Repair (See Section 7, REPLACE / REPAIR)
	Inspect ram in the Power "OFF" (ram retracted) position to verify ram returns freely to the home position	Return Tool for Repair (See Section 7, REPLACE / REPAIR)

Figure 3

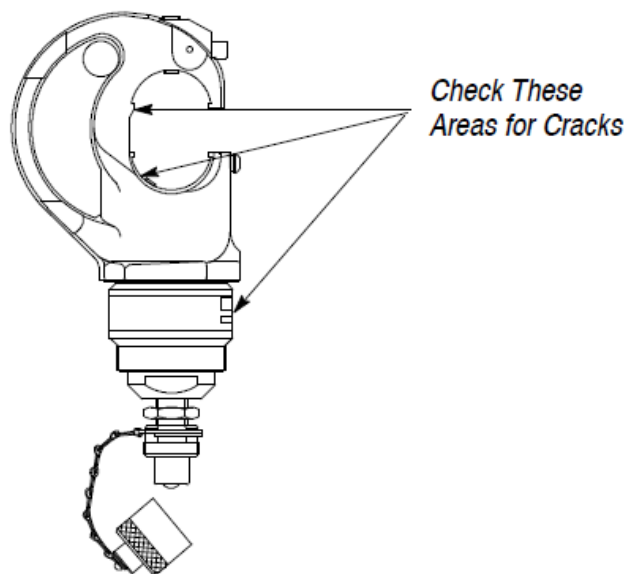

Figure 4

6.3. Crimping Head Check-Out Procedure

If the ram fails to return to the “DOWN” position after completion of a crimping cycle, the cause may be in the crimping head. To determine whether the trouble is in the crimping head or not, release pressure in the hydraulic system.

If the ram retracts, the trouble is not in the crimping head.

If ram does NOT retract, return the crimping head to TE for repairs. Refer to Section 7; REPLACEMENT AND REPAIR.

7. REPLACEMENT AND REPAIR

Customer-replaceable parts are listed in Figure 5. A complete inventory should be stocked and controlled to prevent lost time when replacement of parts is necessary. Order parts through your TE representative or call 1-800-526-5142, or send a facsimile of your purchase order to 1-717-986-7605, or write, or return the entire tool for evaluation and repair, with a written description of the problem to:

CUSTOMER SERVICE (38-35)
 TE CONNECTIVITY CORPORATION
 P.O. BOX 3608
 HARRISBURG, PA 17105-3608

Tools may also be returned for evaluation and repair. For tool repair service, contact a TE representative at 1-800-526-5136.

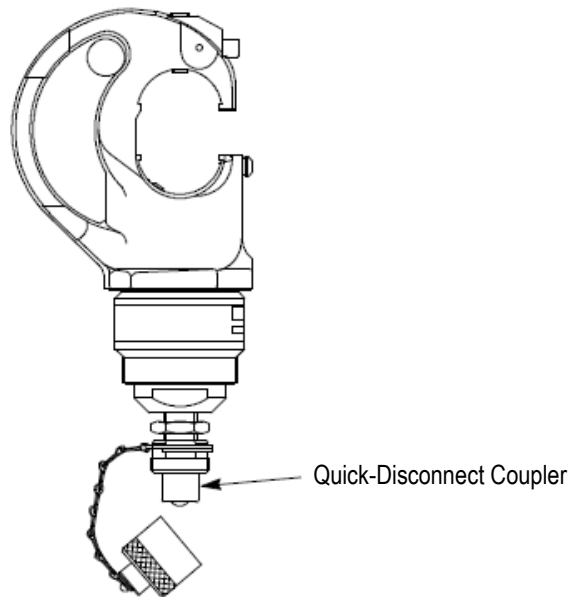

Part Number	Description	Qty Per Head
311470-1	Coupler, Quick-Disconnect, Cylinder Half	1

Figure 5

8. REVISION SUMMARY

This was a major revision. This resulted in changes to most sections and all figures. Highlights include updating to the current TE format, logo, and enterprise name, the addition of a WARNING in Section 1, and updating electric hydraulic pump from part number 1583660-[] to 1804700-1 (115 VAC) and 1804700-2 (220 VAC).

Mouser Electronics

Authorized Distributor

Click to View Pricing, Inventory, Delivery & Lifecycle Information:

[TE Connectivity:](#)

[1490747-1](#)