

---

# ML610Q111/ML610Q112

---

## 8-bit Microcontroller

---

### GENERAL DESCRIPTION

This LSI is a high-performance 8-bit CMOS microcontroller into which rich peripheral circuits, such as timers, PWM, UART, I<sup>2</sup>C bus interface (master/slave), synchronous serial port, voltage level supervisor analog comparators and 10-bit successive approximation type A/D converter, are incorporated around 8-bit CPU nX-U8/100.

The CPU nX-U8/100 is capable of efficient instruction execution in 1-instruction 1-clock mode by pipe line architecture parallel processing. The Flash ROM that is installed as program memory, and the on-chip debug function that is installed, enable program debugging and programming on customer's board.

### FEATURES

- CPU
  - 8-bit RISC CPU (CPU name: nX-U8/100)
  - Instruction system: 16-bit instructions
  - Instruction set:  
Transfer, arithmetic operations, comparison, logic operations, multiplication/division, bit manipulations, bit logic operations, jump, conditional jump, call return stack manipulations, arithmetic shift, and so on
  - On-Chip debug function
  - Minimum instruction execution time:
    - 30.5us (@32.768kHz system clock)
    - 0.122us (@8.192MHz system clock)
- Internal memory
  - ML610Q111:  
Flash memory :
    - Internal 24Kbyte Flash memory (12K x 16bit) for program including unusable 32byte test data area.
    - Internal 4Kbyte Flash memory (2K x 16bit) for data.SRAM :
    - Internal 2Kbyte data RAM (2K x 8bit)
  - ML610Q112:  
Flash memory :
    - Internal 32Kbyte Flash memory (16K x 16bit) for program including unusable 32byte test data area.
    - Internal 4Kbyte Flash memory (2K x 16bit) for data.SRAM :
    - Internal 4Kbyte data RAM (4K x 8bit)
  - Flash Memory operating condition and specification
    - Refer to the chapter Electrical characteristics "FLASH MEMORY SPECIFICATION".
- Interrupt controller
  - 1 non-maskable interrupt source (Internal source: 1(WDT))
  - 30 maskable interrupt sources (Internal sources: 23, External source: 7)
- Time base counter (TBC)
  - Low-speed time base counter: 1 channel
  - High-speed time base counter: 1 channel  
(This time base counter is divided by 1-16, then it can be used as a clock of the Timer and PWM.)

- Watchdog timer (WDT)
  - Non-maskable interrupt and reset  
(Non-maskable interrupt is generated by the first overflow, and reset is generated by the second overflow)
  - Free running
  - Overflow period: 7 types selectable by software (23.4ms, 31.25ms, 62.5ms, 125ms, 500ms, 2s, and 8s)
- Timer
  - 8-bit x 6 channels (16-bit configuration available, 16-bit x 3ch)
  - Supports auto reload timer mode/One shot timer mode
  - Timer count start/stop by software or external input trigger  
(Timer function with external trigger input supports for only 2ch. Selectable external pins/analog comparator output as an external trigger.)
  - The effective minimum pulse width of the external trigger input: Timer clock 3 $\phi$  (about 183 ns @ 16.384 MHz)
  - Allows measurement of pulse width etc. using an external trigger input.
  - 8-selectable clock frequency as counter clock per channel
- PWM
  - Resolution 16-bit
  - Single output x 3ch, Multiple three outputs x 1ch
  - Allows an output of the PWM signal in a cycle of about 122ns (@PLLCLK = 16.384MHz) to 2s (@LSCLK = 32.768kHz)
  - Supports one shot PWM mode
  - PWM start/stop by software and external trigger input  
(Selectable external pins, analog comparator output or timer interrupt as external trigger)
  - 3-selectable clock frequency as PWM clock per channel
- UART
  - TXD/RXD x 2ch
  - Half-Duplex Communication
  - Bit length, parity/no parity, odd parity/even parity, 1 stop bit/2 stop bits
  - Positive logic/negative logic selectable
  - Built-in baud rate generator
- I<sup>2</sup>C bus interface
  - Master function: standard mode (100kbit/s@8MHz), Fast mode (400kbit/s@8MHz)
  - Slave function : standard mode (100kbit/s)
- Synchronous serial port (SSIO)
  - 1ch
  - Master/slave selectable
  - LSB first/MSB first selectable
  - 8-bit length/16-bit length selectable
- Successive approximation type A/D converter (SA-ADC)
  - 10-bit A/D converter
  - Analog Input
    - 6ch (ML610Q111)
    - 8ch (ML610Q112)

- Analog comparator
  - 2ch
    - ch0: Allows comparison of the voltage level of the two external pins or comparison of one external pin and internal reference voltage level.
    - ch1: Allows comparison of one external pin and internal reference voltage level
  - Input common mode voltage range :  $V_{DD} = 0.1V$  to  $V_{DD} - 1.5V$
  - Internal reference voltage : 0.1-0.8V (Selectable in 50mV increments)
  - Hysteresis (Comparator0 only): 20mV(Typ.)
  - Allows selection of with/without interrupt sampling and interrupt edge.
- General-purpose ports (GPIO)
  - Input/output port
    - 15ch (ML610Q111)
    - 25ch (ML610Q112)
- Reset
  - Reset by the RESET\_N pin
  - Reset by power-on detection
  - Reset by the watchdog timer (WDT) 2nd overflow
  - Reset by the voltage level supervisor (VLS) function: Selectable by software
- Voltage level supervisor (VLS)
  - 2ch
    - ch0: It can be used for voltage level detection reset
    - ch1: It can be used for voltage level detection interrupt
  - Judgment accuracy:  $\pm 3.0\%$  (Typ.)
- Clock
  - Low-speed clock:
    - Built-in RC oscillation (32.768kHz)
  - High-speed clock:
    - Built-in PLL oscillation (16.384MHz)
    - High-speed external clock (max. 8.192MHz)
 Maximum CPU clock is 8.192MHz.
  - Selection of high-speed clock mode by software:
    - Built-in PLL oscillation
    - External clock
- Power management
  - HALT mode: Instruction execution by CPU is suspended (peripheral circuits are in operating states)
  - STOP mode: Stop of oscillation (Operations of CPU and peripheral circuits are stopped.)
  - Clock gear: The frequency of system clock can be changed by software (1/1, 1/2, 1/4, or 1/8 of the oscillation clock).
  - Block Control Function: Power down (reset registers and stop clock supply) the circuits of unused peripherals.

- Shipment
  - ML610Q111:
    - 20-pin TSSOP:
      - ML610Q111-xxxTD (blank product: ML610Q111-NNNTD)
  - ML610Q112:
    - 32-pin LQFP:
      - ML610Q112-xxxTC (blank product: ML610Q112-NNNTC)
- Guaranteed operating range
  - Operating temperature (ambience): -40°C to 105°C (Flash write/erase: -20°C to +85°C)
  - Operating voltage: VDD=2.7V to 5.5V

**BLOCK DIAGRAM**

The block diagram is shown in figure 1.

“\*” means secondary function, tertiary function or quaternary function of each port.

“( )<sup>\*2</sup>” means the function of ML610Q112.

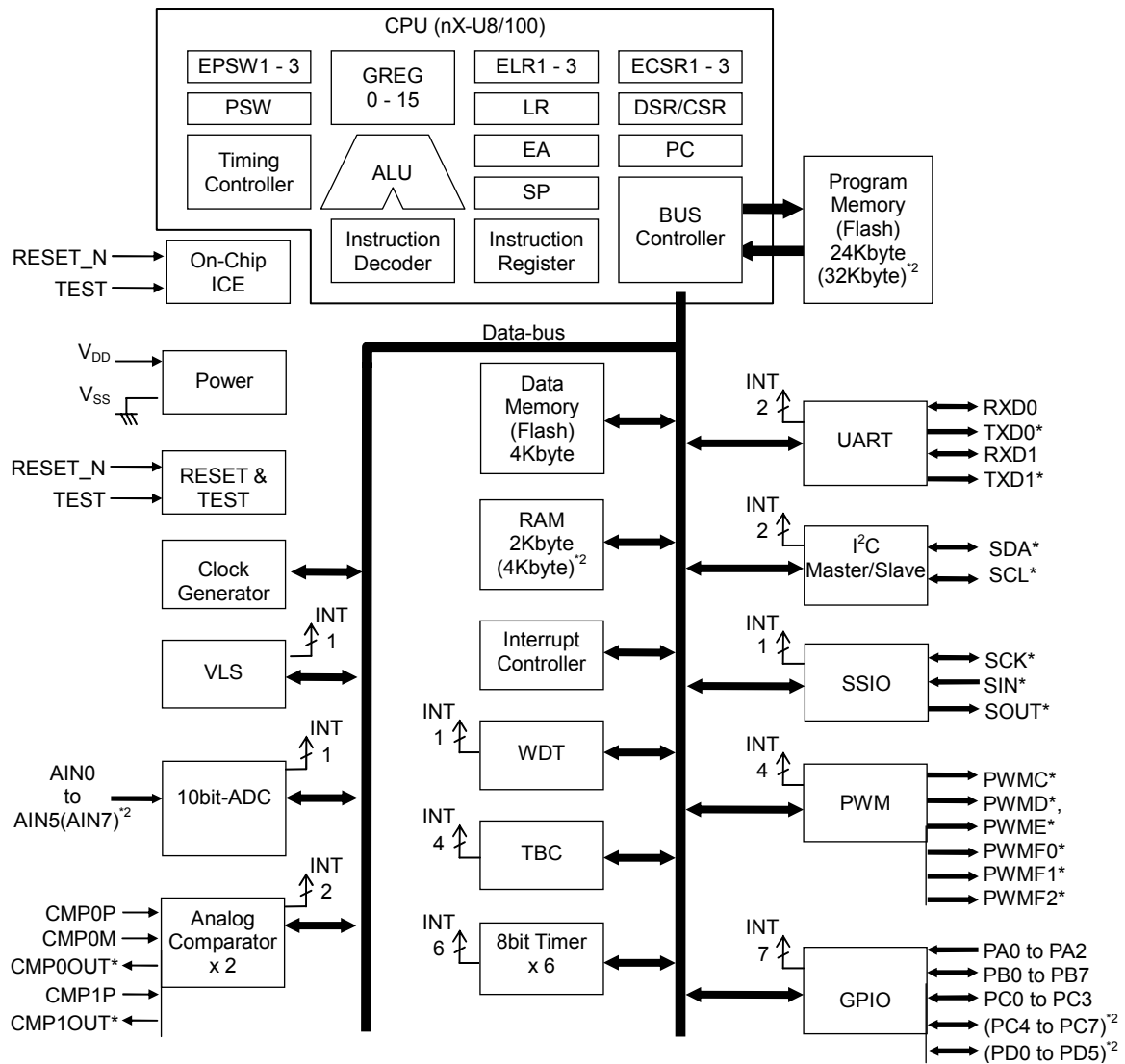

**Figure 1. ML610Q111/ML610Q112 Block Diagram**

**PIN CONFIGURATION (TOP VIEW)**

- ML610Q111-xxxTD  
The pin layout is shown in figure 2.

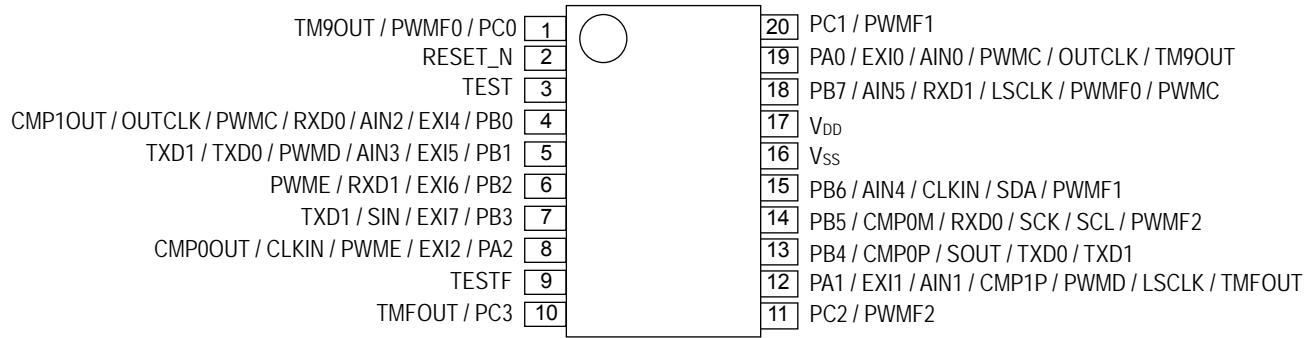

\* PIN No.4-8, 12-15, 18, 19 can be used as external trigger of the Timer E-F and PWMC-F.

**Figure 2. ML610Q111 TSSOP20 Pin Configuration**

- ML610Q112-xxxTC  
The pin layout is shown in figure 3.

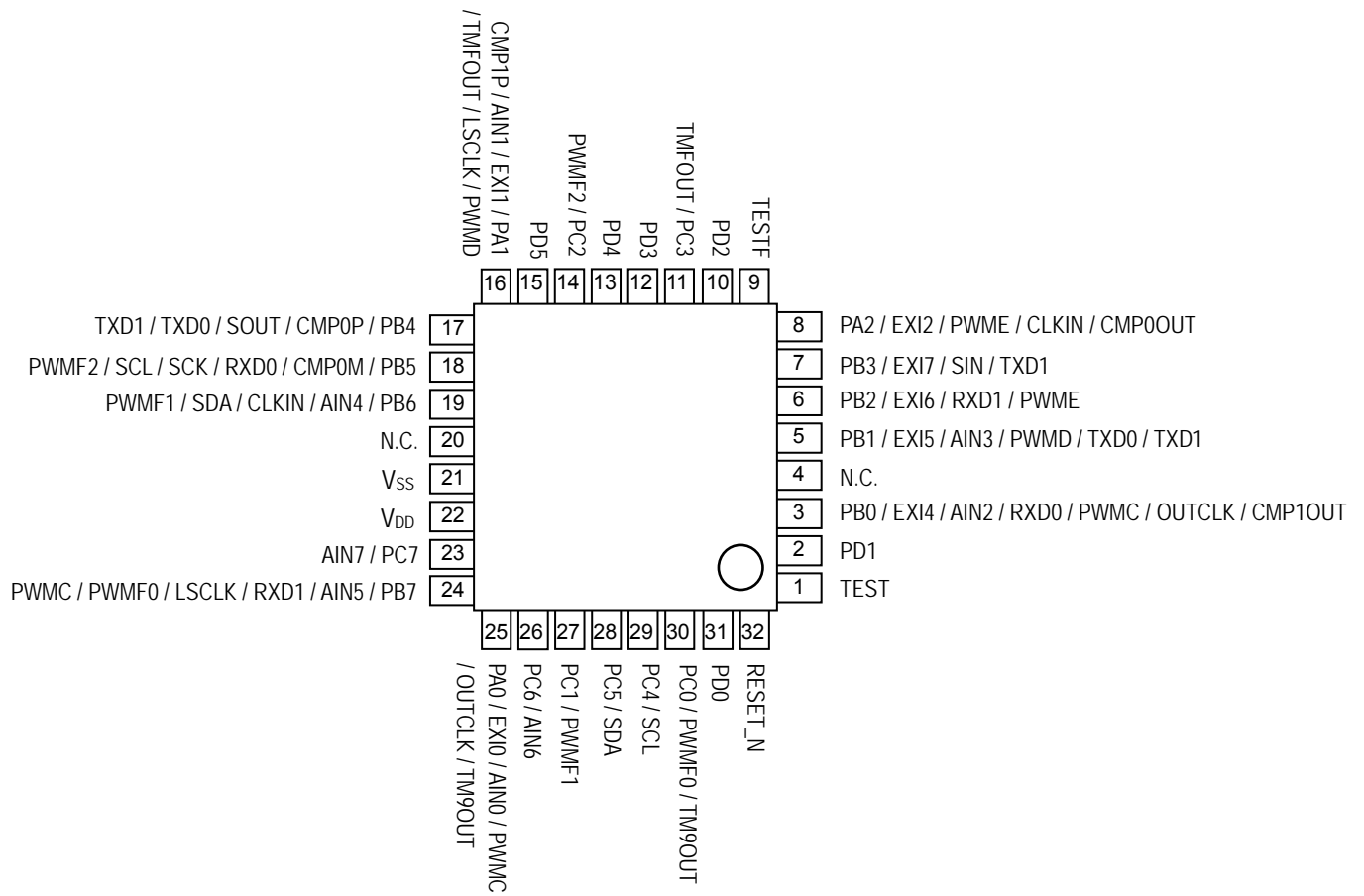

\* PIN No.3, 5-8, 16-19, 24, 25 can be used as external trigger of the Timer E- F and PWMC-F.

**Figure 3. ML610Q112 LQFP32 Pin Configuration**

**PIN LIST**

**Table 1. ML610Q111/ML610Q112 Pin List**

PIN No.		Primary function			Secondary function			Tertiary function			Quaternary function		
32 LQFP	20 TSSOP	Name	I/O	Function	Name	I/O	Function	Name	I/O	Function	Name	I/O	function
21	16	V <sub>SS</sub>	—	power supply	—	—	—	—	—	—	—	—	—
22	17	V <sub>DD</sub>	—	power supply	—	—	—	—	—	—	—	—	—
9	9	TESTF	—	TEST	—	—	—	—	—	—	—	—	—
32	2	RESE T_N	I	SYSTEM	—	—	—	—	—	—	—	—	—
1	3	TEST	I/O	TEST	—	—	—	—	—	—	—	—	—
25	19	PA0/ EXI0/ AIN0/ TnTG <sup>+</sup> / PmTG <sup>**</sup>	I/O	GPIO/ EXINT/ SA-ADC/ TIMER/ PWM	PWMC	O	PWM	OUTCLK	O	SYSTEM	TM9OUT	O	TIMER
16	12	PA1/ EXI1/ AIN1/ CMP1P/ TnTG <sup>+</sup> / PmTG <sup>**</sup>	I/O	GPIO/ EXINT/ SA-ADC/ COMP/ TIMER/ PWM	PWMD	O	PWM	LSCLK	O	SYSTEM	TMFOUT	O	TIMER
8	8	PA2/ EXI2/ TnTG <sup>+</sup> / PmTG <sup>**</sup>	I/O	GPIO/ EXINT/ TIMER/ PWM	PWME	O	PWM	CLKIN	I	SYSTEM	CMP0OUT	O	COMP
3	4	PB0/ EXI4/ AIN2/ RXD0/ TnTG <sup>+</sup> / PmTG <sup>**</sup>	I/O	GPIO/ EXINT/ SA-ADC/ UART/ TIMER/ PWM	PWMC	O	PWM	OUTCLK	O	SYSTEM	CMP1OUT	O	COMP
5	5	PB1/ EXI5/ AIN3/ TnTG <sup>+</sup> / PmTG <sup>**</sup>	I/O	GPIO/ EXINT/ SA-ADC/ TIMER/ PWM	PWMD	O	PWM	TXD0	O	UART	TXD1	O	UART
6	6	PB2/ EXI6/ RXD1/ TnTG <sup>+</sup> / PmTG <sup>**</sup>	I/O	GPIO/ EXINT/ UART/ TIMER/ PWM	PWME	O	PWM	—	—	—	—	—	—
7	7	PB3/ EXI7/ TnTG <sup>+</sup> / PmTG <sup>**</sup>	I/O	GPIO/ EXINT/ TIMER/ PWM	SIN	I	SSIO	TXD1	O	UART	—	—	—
17	13	PB4/ CMP0P	I/O	GPIO/ COMP	SOUT	O	SSIO	TXD0	O	UART	TXD1	O	UART
18	14	PB5/ RXD0/ CMP0M	I/O	GPIO/ UART/ COMP	SCK	I/O	SSIO	SCL	I/O	I <sup>2</sup> C	PWMF2	O	PWM
19	15	PB6/ AIN4	I/O	GPIO/ SA-ADC	CLKIN	I	SYSTEM	SDA	I/O	I <sup>2</sup> C	PWMF1	O	PWM
24	18	PB7/ AIN5/ RXD1	I/O	GPIO/ SA-ADC/ UART	LSCLK	O	SYSTEM	PWMF0	O	PWM	PWMC	O	PWM
30	1	PC0	I/O	GPIO	—	—	—	PWMF0	O	PWM	TM9OUT	O	TIMER
27	20	PC1	I/O	GPIO	—	—	—	PWMF1	O	PWM	—	—	—
14	11	PC2	I/O	GPIO	—	—	—	PWMF2	O	PWM	—	—	—
11	10	PC3	I/O	GPIO	—	—	—	—	—	—	TMFOUT	O	TIMER



PIN No.		Primary function			Secondary function			Tertiary function			Quaternary function		
32 LQFP	20 TSSOP	Name	I/O	Function	Name	I/O	Function	Name	I/O	Function	Name	I/O	function
29	—	PC4	I/O	GPIO	SCL	I/O	I <sup>2</sup> C	—	—	—	—	—	—
28	—	PC5	I/O	GPIO	SDA	I/O	I <sup>2</sup> C	—	—	—	—	—	—
26	—	PC6/ AIN6	I/O	GPIO/ SA-ADC	—	—	—	—	—	—	—	—	—
23	—	PC7/ AIN7	I/O	GPIO/ SA-ADC	—	—	—	—	—	—	—	—	—
31	—	PD0	I/O	GPIO/	—	—	—	—	—	—	—	—	—
2	—	PD1	I/O	GPIO/	—	—	—	—	—	—	—	—	—
10	—	PD2	I/O	GPIO	—	—	—	—	—	—	—	—	—
12	—	PD3	I/O	GPIO	—	—	—	—	—	—	—	—	—
13	—	PD4	I/O	GPIO	—	—	—	—	—	—	—	—	—
15	—	PD5	I/O	GPIO	—	—	—	—	—	—	—	—	—

\* : TnTG = TETG, TFTG.

\*\* : PmTG = PCTG, PDTG, PETG, PFTG.

**PIN DESCRIPTION**

**Table 2. ML610Q111/ML610Q112 Pin Description**

Pin name	I/O	Description	Primary Secondary Tertiary, Quaternary	Logic
<b>System</b>				
RESET_N	I	Reset input pin. When this pin is set to “L” level, system reset mode is set and the internal section is initialized. When this pin is set to “H” level subsequently, program execution starts. A pull-up resistor is internally connected.	Primary	Negative
CLKIN	I	High-speed clock input pin. This pin is used as the secondary function of PB6 pin and also as the tertiary function of PA2 pin.	Secondary, Tertiary	—
LSCLK	O	Low-speed clock output pin. This pin is used as the secondary function of PB7 pin and also as the tertiary function of the PA1.	Secondary, Tertiary	—
OUTCLK	O	High-speed clock output pin. This pin is used as the tertiary function of the PA0 and PB0 pin.	Tertiary	—
<b>General Purpose Input/Output Port</b>				
PA0 to PA2 PB0 to PB7 PC0 to PC7 PD0 to PD5	I/O	General-purpose input/output port. Since these pins have secondary, tertiary or quaternary functions, the pins cannot be used as a port when the secondary, tertiary or quaternary functions are used.	Primary	Positive
<b>Synchronous Serial I/O</b>				
SIN	I	Synchronous serial data input pin. This pin is used as the secondary function of PB3 pin.	Secondary	Positive
SCK	I/O	Synchronous serial clock input/output pin. This pin is used as the secondary function of PB5 pin.	Secondary	—
SOUT	O	Synchronous serial data output pin. This pin is used as the secondary function of PB4 pin.	Secondary	Positive
<b>UART</b>				
TXD0	O	UART0 data output pin. This pin is used as the tertiary function of the PB1 and PB4 pin.	Tertiary	Positive
RXD0	I	UART0 data input pin. This pin is used as the primary function of the PB0 and PB5 pin	Primary	Positive
TXD1	O	UART1 data output pin. This pin is used as the tertiary function of the PB3 pin and also the quaternary function of the PB1 and PB4 pin.	Tertiary Quaternary	Positive
RXD1	I	UART1 data input pin. This pin is used as the primary function of the PB2 and PB7 pin.	Primary	Positive
<b>I<sup>2</sup>C Bus Interface</b>				
SCL	I/O	Serial clock input/output. This pin is used as the tertiary function of the PB5 and the secondary function of the PC4 pin.	Tertiary Secondary	Positive
SDA	I/O	Serial data input/output. This pin is used as the tertiary function of the PB6 and the secondary function of the PC5 pin.	Tertiary Secondary	Positive
<b>PWM</b>				
PWMC	O	PWMC output pin. This pin is used as the secondary function of the PA0 and PB0 and also the quaternary function of the PB7 pin.	Secondary Quaternary	Positive/ Negative
PWMD	O	PWMD output pin. This pin is used as the secondary function of the PA1 and PB1 pin.	Secondary	Positive/ Negative
PWME	O	PWME output pin. This pin is used as the secondary function of the PA2 and PB2 pin.	Secondary	Positive/ Negative
PWMF0	O	PWMF0 output pin. This pin is used as the tertiary function of the PB7 and PC0 pin.	Tertiary	Positive/ Negative
PWMF1	O	PWMF1 output pin. This pin is used as the tertiary function of the PC1 and also the quaternary function of PB6 pin.	Tertiary/ Quaternary	Positive/ Negative

Pin name	I/O	Description	Primary Secondary Tertiary, Quaternary	Logic
PWMF2	O	PWMF2 output pin. This pin is used as the tertiary function of the PC2 and also the quaternary function of the PB5 pin.	Tertiary/ Quaternary	Positive/ Negative
<b>External Interrupt</b>				
EXI0 to 2	I	External maskable interrupt input pins. Interrupt enable and edge selection can be performed for each bit by software. These pins are used as the primary functions of the PA0 – PA2 pins.	Primary	Positive/ negative
EXI4 to 7	I	External maskable interrupt input pins. Interrupt enable and edge selection can be performed for each bit by software. These pins are used as the primary functions of the PB0 – PB3 pins.	Primary	Positive/ negative
<b>Timer</b>				
TETE, TFTG	I	External clock input pin used for both Timer E and Timer F. These pins are used as the primary function of the PA0-PA2, PB0-PB7 pins.	Primary	—
TM9OUT	O	Timer 9 output pin. This pin is used as the quaternary function of the PA0 and PC0 pin.	Quaternary	Positive
TMFOUT	O	Timer F output pin. This pin is used as the quaternary function of the PA1 and PC3 pin.	Quaternary	Positive
<b>Successive approximation type A/D converter</b>				
AIN0	I	Channel 0 analog input for successive approximation type A/D converter. This pin is used as the primary function of the PA0 pin.	Primary	—
AIN1	I	Channel 1 analog input for successive approximation type A/D converter. This pin is used as the primary function of the PA1 pin.	Primary	—
AIN2	I	Channel 2 analog input for successive approximation type A/D converter. This pin is used as the primary function of the PB0 pin.	Primary	—
AIN3	I	Channel 3 analog input for successive approximation type A/D converter. This pin is used as the primary function of the PB1 pin.	Primary	—
AIN4	I	Channel 4 analog input for successive approximation type A/D converter. This pin is used as the primary function of the PB6 pin.	Primary	—
AIN5	I	Channel 5 analog input for successive approximation type A/D converter. This pin is used as the primary function of the PB7 pin.	Primary	—
AIN6	I	Channel 6 analog input for successive approximation type A/D converter. This pin is used as the primary function of the PC6 pin.	Primary	—
AIN7	I	Channel 7 analog input for successive approximation type A/D converter. This pin is used as the primary function of the PC7 pin.	Primary	—
<b>Comparator</b>				
CMP0P	I	Non-inverting input for comparator0. This pin is used as the primary function of the PB4 pin.	Primary	—
CMP0M	I	Inverting input for comparator0. This pin is used as the primary function of the PB5 pin.	Primary	—
CMP0OUT	O	Output for comparator0. This pin is used as the quaternary function of the PA2 pin.	Quaternary	—
CMP1P	I	Non-inverting input for comparator1. This pin is used as the primary function of the PA1 pin.	Primary	—
CMP1OUT	O	Output for comparator1. This pin is used as the quaternary function of the PB0 pin.	Quaternary	—
<b>TEST</b>				
TEST	I/O	Input/output pin for testing. A pull-down resistor is internally connected.	—	Positive
TESTF	—	Test pin for flash memory. A pull-down resistor is internally connected.	—	—
<b>Power Supply</b>				
V <sub>SS</sub>	—	Negative power supply pin.	—	—
V <sub>DD</sub>	—	Positive power supply pin.	—	—

## TERMINATION OF UNUSED PINS

Table 3 shows methods of terminating the unused pins for ML610Q111/ML610Q112

**Table 3. Termination of Unused Pins**

Pin	Recommended pin termination
RESET_N	Open
TEST	Open
TESTF	Open
PA0 to PA2	Open
PB0 to PB7	Open
PC0 to PC7	Open
PD0 to PD5	Open
N.C.	Open

**Note:**

It is recommended to set the unused input ports and input/output ports to the inputs with pull-down resistors/pull-up resistors or the output mode since the supply current may become excessively large if the pins are left open in the high impedance input setting.

## ELECTRICAL CHARACTERISTICS

### ● ABSOLUTE MAXIMUM RATINGS

(V<sub>SS</sub>=0V)

Parameter	Symbol	Condition	Rating	Unit
Power supply voltage	V <sub>DD</sub>	Ta = 25°C	-0.3 to +7.0	V
Input voltage	V <sub>IN</sub>	Ta = 25°C	-0.3 to V <sub>DD</sub> +0.3	V
Output voltage	V <sub>OUT</sub>	Ta = 25°C	-0.3 to V <sub>DD</sub> +0.3	V
Output current	I <sub>OUT</sub>	Ta = 25°C	-12 to +11	mA
Power dissipation	PD	Ta = 25°C	0.84	W
Storage temperature	T <sub>STG</sub>	—	-55 to 150	°C

### ● RECOMMENDED OPERATING CONDITIONS

(V<sub>SS</sub>=0V)

Parameter	Symbol	Condition	Range	Unit
Operating temperature (ambience)	T <sub>OP</sub>	—	-40 to +105	°C
Operating voltage	V <sub>DD</sub>	—	2.7 to 5.5	V

### ● FLASH MEMORY SPECIFICATION

(V<sub>SS</sub>= 0V)

Parameter	Symbol	Condition	Rating	Unit
Operating temperature (ambience)	T <sub>OPF</sub>	At read	-40 to +105	°C
		At write/erase	-20 to +85	°C
Rewrite counts <sup>*1</sup>	C <sub>EPD</sub>	Data flash memory (4KB)	6000	cycles
	C <sub>EPP</sub>	Program flash memory	80	
Erase unit	—	Chip-erase	Program flash and Data flash memory	—
	—	Block-erase (Program flash memory)	8	KB
	—	Block-erase (Data flash memory)	4	KB
	—	Sector-erase (Data flash memory)	1	KB
Erase time (max.)	—	Chip-erase/Block-erase/Sector-erase	100	ms
Write unit	—	—	1word(2bytes)	—
Write time (max.)	—	1word(2bytes)	40	μs
Data retention <sup>*2</sup>	Y <sub>DR</sub>	—	15	years

\*<sup>1</sup>: Rewrite counts is counted as one even if you erase suspend.

\*<sup>2</sup>: However, keep active time of the LSI from exceeding ten years.

In addition, following capability of Flash memory is available;

- security function: providing security ID for the protection of program code implemented in Flash memory

- accidental-write protection: providing special sequence to protect accidental write data to Flash memory. By writing "0FAx" and "0F5x" sequentially, before write/erase, writing one word is available just only one time.

- erase interrupt function: in the case of external interrupt during erasing flash memory, erase execution is suspended. And then the interrupt is activated. Please re-erase after interrupt execution.

● DC CHARACTERISTICS (Supply Current)

( $V_{DD}=2.7$  to  $5.5V$ ,  $V_{SS}=0V$ ,  $T_a=-40$  to  $+105^{\circ}C$ , unless otherwise specified)

Parameter	Symbol	Condition	Rating			Unit	Measuring circuit
			Min.	Typ.	Max.		
Supply current 1	IDD1	CPU : In STOP state (All clock stop) $V_{DD}=5.0V$	—	1	50	$\mu A$	1
Supply current 2	IDD2	CPU : In HALT state* <sup>1</sup> (Only CR oscillation operates) $V_{DD}=5.0V$	—	240	—	$\mu A$	
Supply current 3	IDD3	CPU : CR32.768kHz operating state* <sup>2</sup> (Only CR oscillation operates) $V_{DD}=5.0V$	—	250	—	$\mu A$	
Supply current 4	IDD4	CPU : CR8.192MHz operating state* <sup>3</sup> (CR and PLL oscillation operate) $V_{DD}=5.0V$	—	4	6	mA	

\*<sup>1</sup> : LTBC and WDT are operating ,and significant bits of BLKCON0 to BLKCON7 registers are all "1".

\*<sup>2</sup> : When the CPU operating rate is 100%. Minimum instruction execution time: Approx 30.52  $\mu s$  (at 32.768kHz system clock)

\*<sup>3</sup> : When the CPU operating rate is 100%. Minimum instruction execution time: Approx 122 ns (at 8.192MHz system clock)

● DC CHARACTERISTICS (VLS, Comparator)

( $V_{DD}=2.7$  to  $5.5V$ ,  $V_{SS}=0V$ ,  $T_a=-40$  to  $+105^{\circ}C$ , unless otherwise specified)

Parameter	Symbol	Condition		Rating			Unit	Measuring circuit
				Min.	Typ.	Max.		
VLS0 threshold voltage ( $V_{DD}=\text{fall}$ )	$V_{VLS0F}$	$T_a=25^{\circ}C$		Typ -3.0%	2.85	Typ +3.0%	V	1
		—		Typ -5.0%		Typ +5.0%		
VLS0 threshold voltage ( $V_{DD}=\text{rise}$ )	$V_{VLS0R}$	$T_a=25^{\circ}C$		Typ -3.0%	2.92	Typ +3.0%		
		—		Typ -5.0%		Typ +5.0%		
VLS1 threshold voltage ( $V_{DD}=\text{fall}$ )	$V_{VLS1}$	$T_a=25^{\circ}C$	VLS1=0	Typ -3.0%	3.3	Typ +3.0%		
			VLS1=1		3.6			
			VLS1=2		3.9			
			VLS1=3		4.2			
		—	Typ -5.0%	VLS1=0	3.3	Typ +5.0%		
				VLS1=1	3.6			
				VLS1=2	3.9			
				VLS1=3	4.2			
Comparator0 In-phase input voltage range	$V_{CMR}$	—		0.1	—	$V_{DD} - 1.5$	V	
Comparator0 hysteresis	$V_{HYSP}$	$T_a=25^{\circ}C$ , $V_{DD} = 5.0V$		10	20	30	mV	
		$V_{DD} = 5.0V$		5	20	35		
Comparator0 Input offset voltage	$V_{CMOF}$	$T_a=25^{\circ}C$ , $V_{DD} = 5.0V$		—	—	7		
Comparator Reference-voltage error* <sup>1</sup>	$V_{CMREF}$	$T_a=25^{\circ}C$		-25	—	25		
		—		-50	—	50		

\*<sup>1</sup>: Comparator input offset voltage is included.

● DC CHARACTERISTICS (IO pins)

( $V_{DD}=2.7$  to  $5.5V$ ,  $V_{SS}=0V$ ,  $T_a=-40$  to  $+105^{\circ}C$ , unless otherwise specified)

Parameter	Symbol	Condition	Rating			Unit	Measuring circuit
			Min.	Typ.	Max.		
Output voltage1 ( TEST, PA0-2, PB0-7, PC0-7, PD0-5 )	VOH1	IOH=-3.0mA, $V_{DD}=4.5V^{*1}$ Ta= -40 to 85°C	$V_{DD}$ -0.7	—	—	V	2
		IOH=-3.0mA, $V_{DD}=4.5V^{*1}$	$V_{DD}$ -0.8	—	—		
	VOL1	IOL=+8.5mA, $V_{DD}=4.5V^{*1}$ Ta= -40 to 85°C	—	—	0.6		
		IOL=+8.5mA, $V_{DD}=4.5V^{*1}$	—	—	0.7		
Output voltage2 (PB5, PB6 PC4, PC5)	VOL2	IOL=+3.0mA	—	—	0.4		
Output leakage ( PA0-2, PB0-7, PC0-7, PD0-5 )	IOOH	VOH = $V_{DD}$ (in high-impedance state)	—	—	1	μA	3
	IOOL	VOL = $V_{SS}$ (in high-impedance state)	-1	—	—		
Input current 1 ( RESET_N )	IIH1	VIH1 = $V_{DD}$	—	—	1	μA	4
	IIL1	VIL1 = $V_{SS}$ , $V_{DD} = 5.0V$	-650	-500	-350		
Input current 2 ( TEST )	IIH2	VIH2= $V_{DD} = 5.0V$	20	115	200		
	IIL2	VIL2 = $V_{SS}$	-1	—	—		
Input current 3 ( PA0-2, PB0-7, PC0-7, PD0-5 )	IIH3	VIH3 = $V_{DD} = 5.0V$ (when pulled-down)	20	115	200		
	IIL3	VIL3 = $V_{SS}$ , $V_{DD} = 5.0V$ (when pulled-up)	-200	-100	-20		
	IIH3Z	VIH3 = $V_{DD}$ (in high-impedance stat)	—	—	1		
	IIL3Z	VIL3 = $V_{SS}$ (in high-impedance stat)	-1	—	—		

\*1 : When the one terminal output state.

( $V_{DD}=2.7$  to  $5.5V$ ,  $V_{SS}=0V$ ,  $T_a=-40$  to  $+105^{\circ}C$ , unless otherwise specified)

Parameter	Symbol	Condition	Rating			Unit	Measuring circuit
			Min.	Typ.	Max.		
Input voltage 1 ( RESET_N, TEST, PA0-2, PB0-7, PC0-7, PD0-5 )	VIH1	—	0.7 $\times V_{DD}$	—	$V_{DD}$	V	2
	VIL1	—	0	—	0.3 $\times V_{DD}$		
Input pin capacitance ( PA0-2, PB0-7, PC0-7, PD0-5 )	CIN	f = 10kHz Ta = 25°C	—	—	20	pF	—



● MEASURING CIRCUITS

Measuring circuit 1

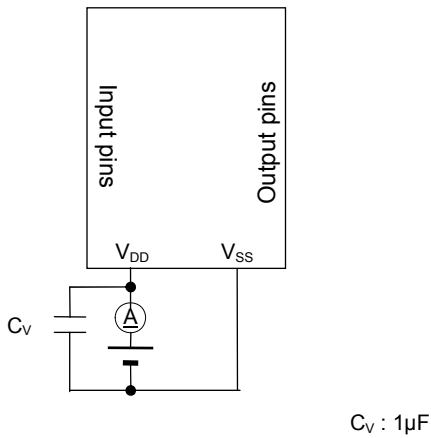

Measuring circuit 2

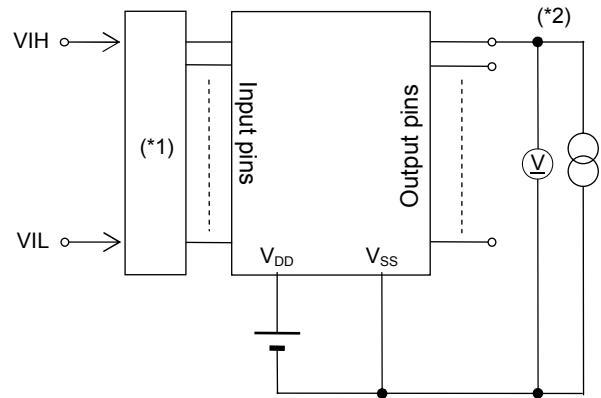

Measuring circuit 3

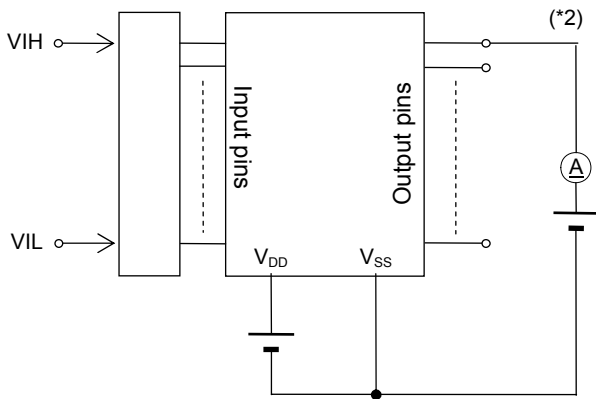

Measuring circuit 4

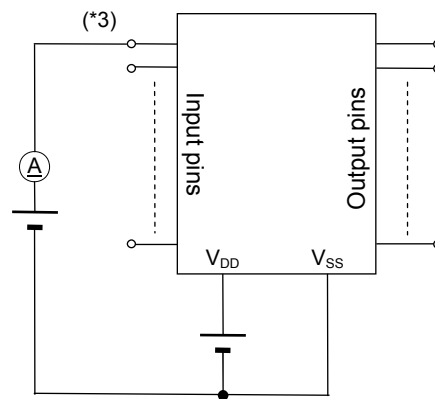

\*1: Input logic circuit to determine the specified measuring conditions.

\*2: Measured at the specified output pins.

\*3: Measured at the specified input pins.

● AC CHARACTERISTICS (Clock)

( $V_{DD}=2.7$  to  $5.5V$ ,  $V_{SS}=0V$ ,  $T_a=-40$  to  $+105^{\circ}C$ , unless otherwise specified)

Parameter	Symbol	Condition	Rating			Unit
			Min.	Typ.	Max.	
32kHz RC oscillation frequency	$f_{RCL}$	$T_a = -20$ to $85^{\circ}C$	Typ. -3%	32.768	Typ. +3%	kHz
		—	Typ. -4%		Typ. +4%	
PLL oscillation frequency *1	$f_{PLL}$	$T_a = -20$ to $85^{\circ}C$	Typ. -3%	16.384	Typ. +3%	MHz
		—	Typ. -4%		Typ. +4%	

\*1 : 1024 clock average. Maximum CPU clock frequency is  $f_{PLL}/2$ .

● AC CHARACTERISTICS (Power on / Reset sequence)

( $V_{DD}=2.7$  to  $5.5V$ ,  $V_{SS}=0V$ ,  $T_a=-40$  to  $+105^{\circ}C$ , unless otherwise specified)

Parameter	Symbol	Condition	Rating			Unit
			Min.	Typ.	Max.	
Reset pulse width	$P_{RST}$	—	100	—	—	$\mu s$
Reset noise elimination pulse width	$P_{NRST}$	—	—	—	0.4	ms
Power-on reset activation power rise time	$T_{POR}$	—	—	—	10	

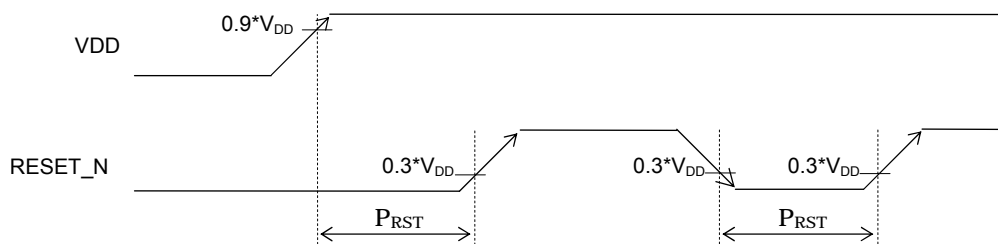

External Reset sequence



Power-on Reset sequence

● AC CHARACTERISTICS (External Interrupt)

( $V_{DD}=2.7$  to  $5.5V$ ,  $V_{SS}=0V$ ,  $T_a=-40$  to  $+105^{\circ}C$ , unless otherwise specified)

Parameter	Symbol	Condition	Rating			Unit
			Min.	Typ.	Max.	
External interrupt disable period	$T_{NUL}$	Interrupt: Enabled (MIE = 1), CPU: NOP operation	2.5 x sysclk	—	3.5 x sysclk	$\phi$

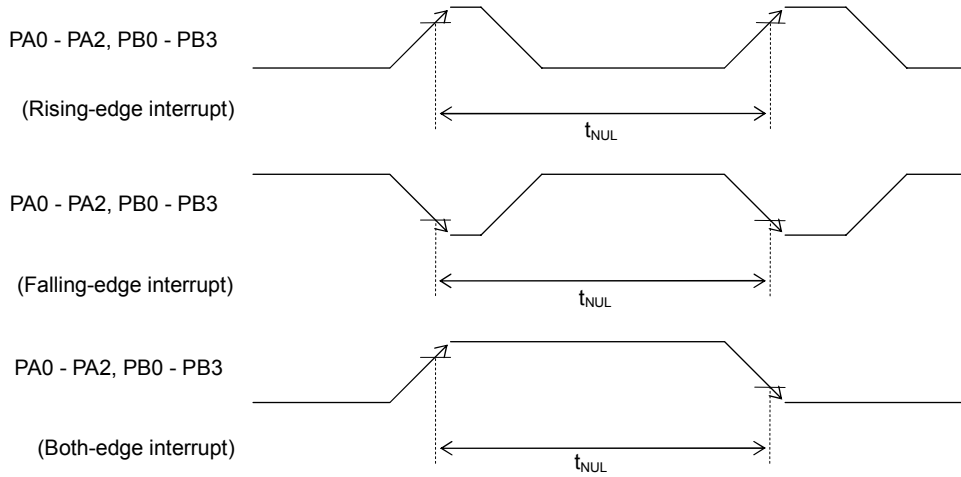

● AC CHARACTERISTICS (Synchronous Serial Port)

( $V_{DD}=2.7$  to  $5.5V$ ,  $V_{SS}=0V$ ,  $T_a=-40$  to  $+105^{\circ}C$ , unless otherwise specified)

Parameter	Symbol	Condition	Rating			Unit
			Min.	Typ.	Max.	
SCK input cycle (slave mode)	$t_{scyc}$	When high-speed oscillation is not active	10	—	—	$\mu s$
		When high-speed oscillation is active	500	—	—	ns
SCK output cycle (master mode)	$t_{scyc}$	—	—	SCK* <sup>1</sup>	—	s
SCK input pulse width (slave mode)	$t_{sw}$	When high-speed oscillation is not active	4	—	—	$\mu s$
		When high-speed oscillation is active	200	—	—	ns
SCK output pulse width (master mode)	$t_{sw}$	—	$t_{scyc} \times 0.4$	$t_{scyc} \times 0.5$	$t_{scyc} \times 0.6$	s
SOUT output delay (slave mode)	$t_{sd}$	—	—	—	180	ns
SOUT output delay (master mode)	$t_{sd}$	—	—	—	80	ns
SIN input setup time (slave mode)	$t_{ss}$	—	50	—	—	ns
SIN input hold time	$t_{sh}$	—	50	—	—	ns

\*<sup>1</sup>: Clock period selected with S0CK3-0 of the serial port 0 mode register(SIO0MOD1)

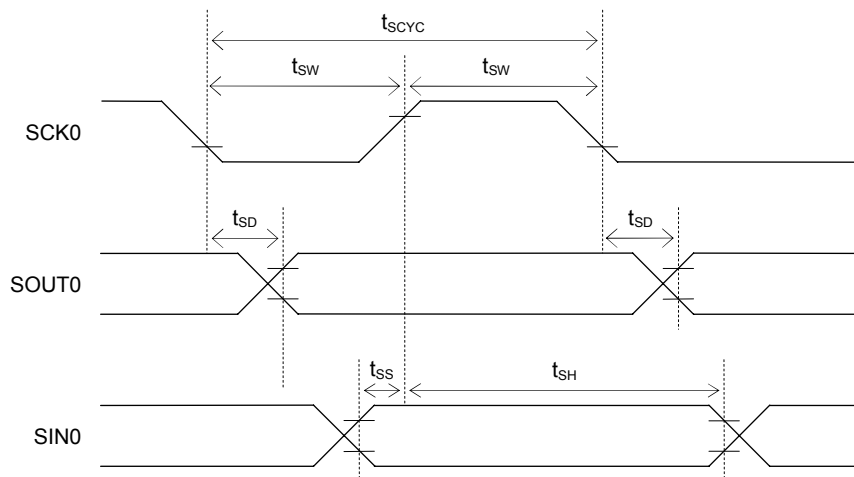

● AC CHARACTERISTICS (I<sup>2</sup>C Bus Interface: Standard Mode 100kHz)

(V<sub>DD</sub>=2.7 to 5.5V, V<sub>SS</sub>=0V, T<sub>a</sub>=-40 to +105°C, unless otherwise specified)

Parameter	Symbol	Condition	Rating			Unit
			Min.	Typ.	Max.	
SCL clock frequency	f <sub>SCL</sub>	—	0	—	100	kHz
SCL hold time (start/restart condition)	t <sub>HD:STA</sub>	—	4.0	—	—	μs
SCL "L" level time	t <sub>LOW</sub>	—	4.7	—	—	μs
SCL "H" level time	t <sub>HIGH</sub>	—	4.0	—	—	μs
SCL setup time (restart condition)	t <sub>SU:STA</sub>	—	4.7	—	—	μs
SDA hold time	t <sub>HD:DAT</sub>	—	0	—	—	μs
SDA setup time	t <sub>SU:DAT</sub>	—	0.25	—	—	μs
SDA setup time (stop condition)	t <sub>SU:STO</sub>	—	4.0	—	—	μs
Bus-free time	t <sub>BUF</sub>	—	4.7	—	—	μs

● AC CHARACTERISTICS (I<sup>2</sup>C Bus Interface: Fast Mode 400kHz)

(V<sub>DD</sub>=2.7 to 5.5V, V<sub>SS</sub>=0V, T<sub>j</sub>=-40 to +105°C, unless otherwise specified)

Parameter	Symbol	Condition	Rating			Unit
			Min.	Typ.	Max.	
SCL clock frequency	f <sub>SCL</sub>	—	0	—	400	kHz
SCL hold time (start/restart condition)	t <sub>HD:STA</sub>	—	0.6	—	—	μs
SCL "L" level time	t <sub>LOW</sub>	—	1.3	—	—	μs
SCL "H" level time	t <sub>HIGH</sub>	—	0.6	—	—	μs
SCL setup time (restart condition)	t <sub>SU:STA</sub>	—	0.6	—	—	μs
SDA hold time	t <sub>HD:DAT</sub>	—	0	—	—	μs
SDA setup time	t <sub>SU:DAT</sub>	—	0.1	—	—	μs
SDA setup time (stop condition)	t <sub>SU:STO</sub>	—	0.6	—	—	μs
Bus-free time	t <sub>BUF</sub>	—	1.3	—	—	μs

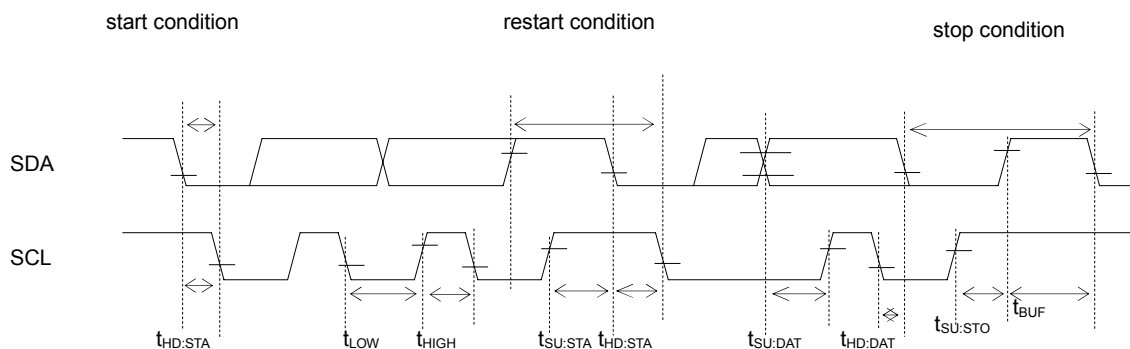

● Electrical Characteristics of Successive Approximation Type A/D Converter

( $V_{DD}=2.7$  to  $5.5V$ ,  $V_{SS}=0V$ ,  $T_a=-40$  to  $+105^{\circ}C$ , unless otherwise specified)

Parameter	Symbol	Condition	Rating			Unit
			Min.	Typ.	Max.	
Resolution	n	—	—	—	10	bit
Integral non-linearity error	INL	—	-4	—	+4	LSB
Differential non-linearity error	DNL	—	-3	—	+3	
Zero-scale error	$V_{OFF}$	—	-4	—	+4	
Full-scale error	FSE	—	-4	—	+4	
Conversion time	$t_{CONV}$	—	—	102	—	$\phi/CH$

$\Phi$  : period of OSCLK (more than 3MHz)

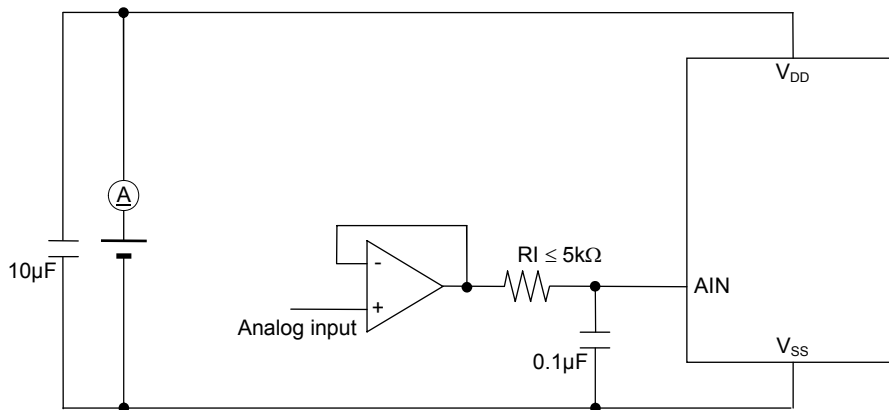

**PACKAGE DIMENSIONS**

- ML610Q111-xxxTD

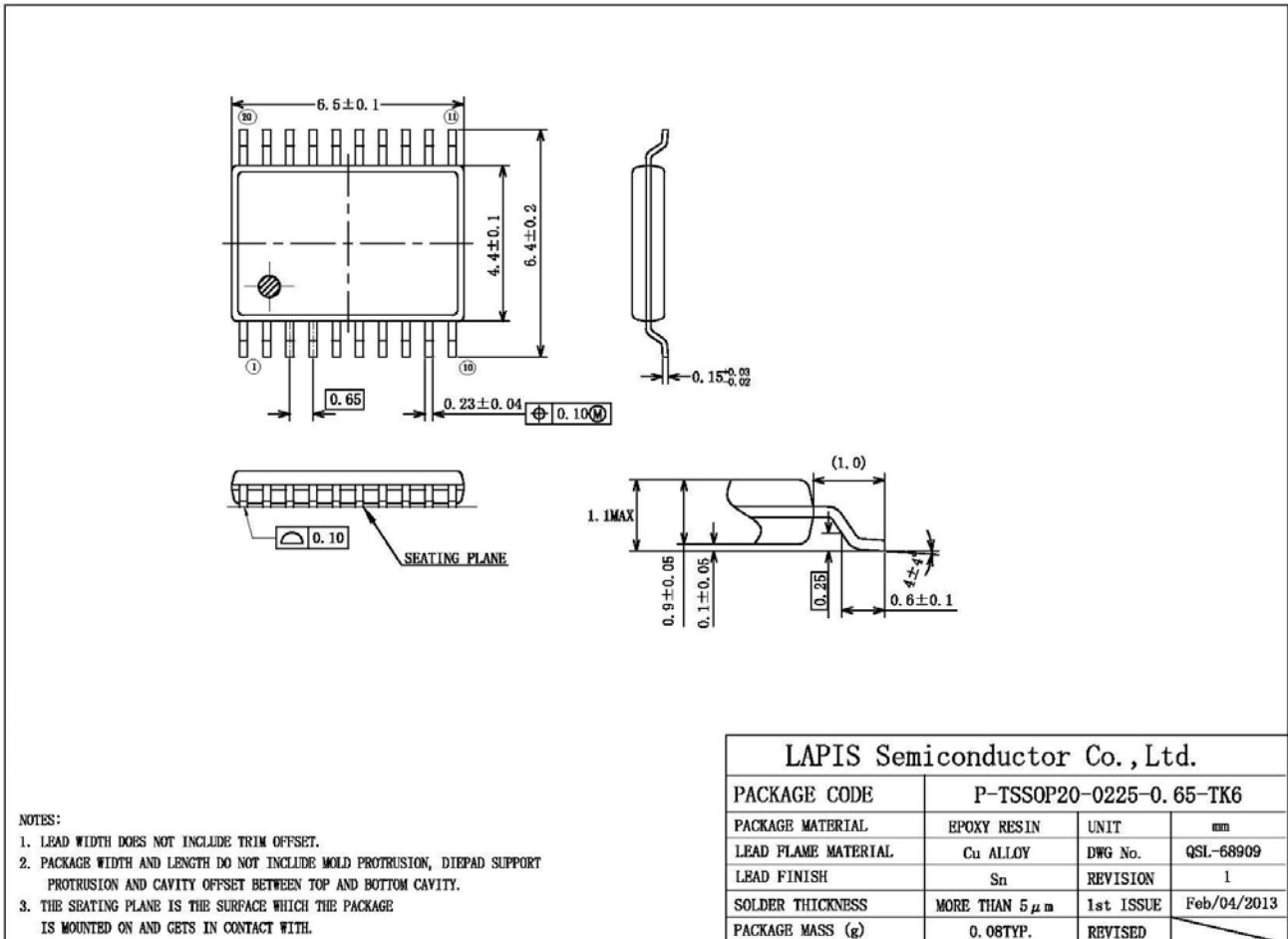

Figure 4 TSSOP20

● ML610Q112-xxxTC

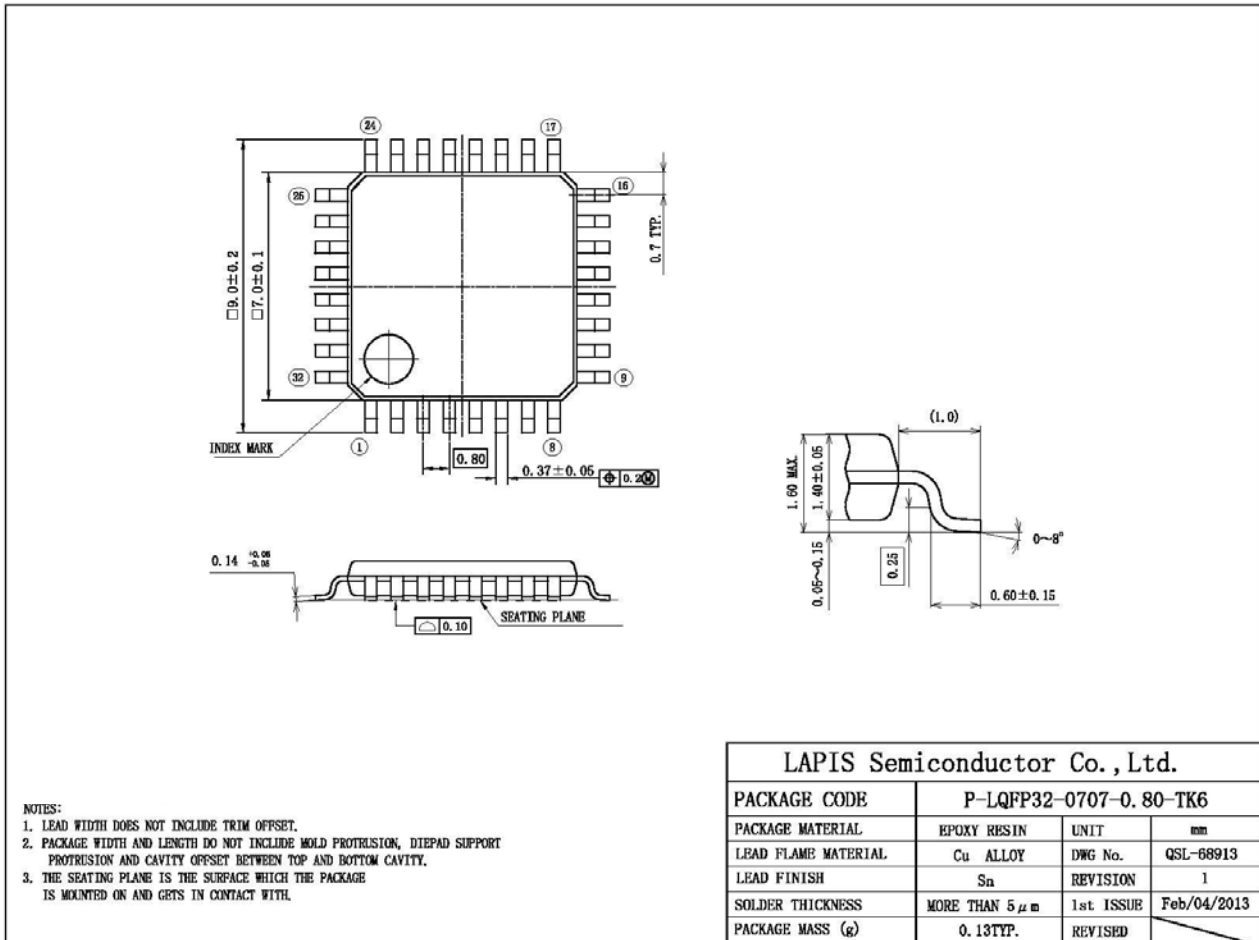

Figure 5 LQFP32

● Notes for Mounting the Surface Mount Type Package

The surface mount type packages are very susceptible to heat in reflow mounting and humidity absorbed in storage. Therefore, before you perform reflow mounting, contact ROHM's responsible sales person for the product name, package name, pin number, package code and desired mounting conditions (reflow method, temperature and times).



**REVISION HISTORY**

Document No.	Date	Page		Description
		Previous Edition	Current Edition	
FEDL610Q111-01	2013.9.26	—	—	Final edition 1

NOTES

No copying or reproduction of this document, in part or in whole, is permitted without the consent of LAPIS Semiconductor Co., Ltd.

The content specified herein is subject to change for improvement without notice.

Examples of application circuits, circuit constants and any other information contained herein illustrate the standard usage and operations of the Products. The peripheral conditions must be taken into account when designing circuits for mass production.

Great care was taken in ensuring the accuracy of the information specified in this document. However, should you incur any damage arising from any inaccuracy or misprint of such information, LAPIS Semiconductor shall bear no responsibility for such damage.

The technical information specified herein is intended only to show the typical functions of and examples of application circuits for the Products. LAPIS Semiconductor does not grant you, explicitly or implicitly, any license to use or exercise intellectual property or other rights held by LAPIS Semiconductor and other parties. LAPIS Semiconductor shall bear no responsibility whatsoever for any dispute arising from the use of such technical information.

The Products specified in this document are intended to be used with general-use electronic equipment or devices (such as audio visual equipment, office-automation equipment, communication devices, electronic appliances and amusement devices).

The Products specified in this document are not designed to be radiation tolerant.

While LAPIS Semiconductor always makes efforts to enhance the quality and reliability of its Products, a Product may fail or malfunction for a variety of reasons.

Please be sure to implement in your equipment using the Products safety measures to guard against the possibility of physical injury, fire or any other damage caused in the event of the failure of any Product, such as derating, redundancy, fire control and fail-safe designs. LAPIS Semiconductor shall bear no responsibility whatsoever for your use of any Product outside of the prescribed scope or not in accordance with the instruction manual.

The Products are not designed or manufactured to be used with any equipment, device or system which requires an extremely high level of reliability the failure or malfunction of which may result in a direct threat to human life or create a risk of human injury (such as a medical instrument, transportation equipment, aerospace machinery, nuclear-reactor controller, fuel-controller or other safety device). LAPIS Semiconductor shall bear no responsibility in any way for use of any of the Products for the above special purposes. If a Product is intended to be used for any such special purpose, please contact a ROHM sales representative before purchasing.

If you intend to export or ship overseas any Product or technology specified herein that may be controlled under the Foreign Exchange and the Foreign Trade Law, you will be required to obtain a license or permit under the Law.

Copyright 2013 LAPIS Semiconductor Co., Ltd.

# Mouser Electronics

Authorized Distributor

Click to View Pricing, Inventory, Delivery & Lifecycle Information:

[ROHM Semiconductor:](#)

[ML610Q112-NNNTCZ07FL](#) [ML610Q111-NNNTDZ07FL](#) [ML610Q112 reference board](#) [ML610Q111 reference board](#)