

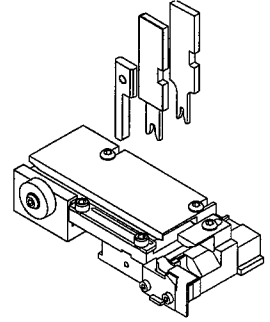

**SPECIFICATION SHEET**  
**T2 Terminator**  
**63850-4100**  
**REVISION B**



**SCOPE**

Terminal Series No	Wire Size		Insulation Diameter		Strip Length	
	Awg	(mm <sup>2</sup> )	mm	(in)	mm	(in)
70021-00**	22-24	(0.35-0.20)	1.40-1.63	(.055-.064)	3.17-3.56	(.125-.140)
50088-80**	22-24	(0.35-0.20)	1.00-1.60	(.039-.063)	3.00-3.50	(.118-.137)

**DEFINITION OF TERMS**

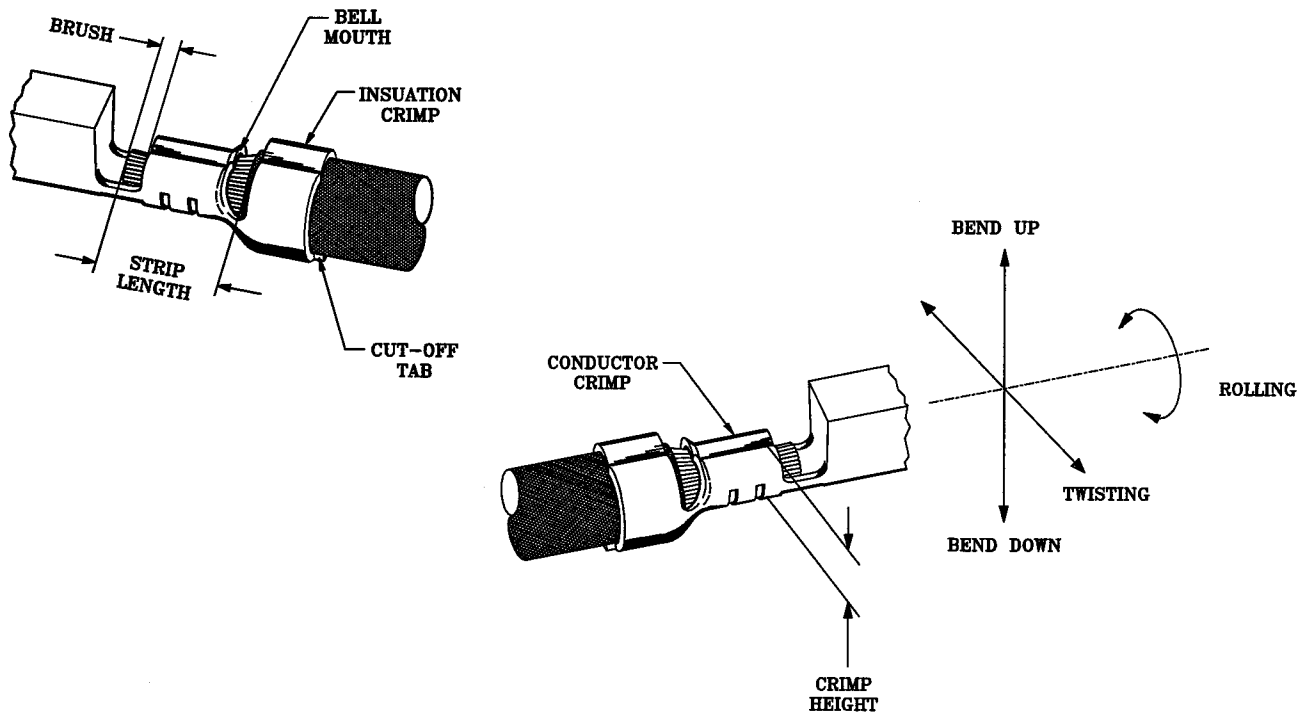

The above terminal drawing is a generic terminal representation. It is not an image of a terminal listed in the scope

## SPECIFICATIONS

Terminal Series No.	Bellmouth		Cut-Off Tab Max.		Conductor Brush	
	mm	(in)	Front mm (in)	Rear mm (in)	mm	(in)
70021-00**	0.20-0.50	(.008-.020)	0.13 (.005)	0.13 (.005)	0.00-1.00	(.000-.039)
50088-80**	0.20-0.50	(.008-.020)	0.15 (.006)	0.30 (.012)	0.00-1.00	(.000-.039)

Terminal Series No.	Bend Up / Bend Down		Twist Degree	Roll Degree	Punch Width mm	
	Degree				Conductor	Insulation
70021-00**	3	3	3	8	1.40	1.60
50088-80**	3	3	3	8	1.40	1.60

The above specifications are guidelines to an optimum crimp.

## CONDITIONS

After crimping, the conductor profile should measure the following.

Terminal Series	Wire Size		Crimp Height		Pull Force Min	
	Awg	(mm <sup>2</sup> )	mm	(in)	N	(lbs)
70021-00**	22	(0.35)	0.84-0.89	(.033-.035)	35.6	(8.0)
70021-00**	24	(0.20)	0.76-0.81	(.030-.032)	22.2	(5.0)
50088-80**	22	(0.35)	0.81-0.89	(.032-.035)	39.1	(8.8)
50088-80**	24	(0.20)	0.74-0.81	(.029-.032)	29.3	(6.6)

Pull Force measured with no influence from the insulation crimp

## PARTS LIST

Item Number	Order Number	Eng Number	Description	Qty	Kit Part
1	634441417	634441417	Conductor Punch	1	Y
2	634451446	634451446	Conductor Anvil	1	Y
3	634461626	634461626	Insulation Punch	1	Y
4	634451630	634451630	Insulation Anvil	1	Y
5	634430003	634430003	Cut-Off Plunger	2	Y
6	634430012	634430012	Front Plunger Retainer	1	Y
16	634431402	634431402	Cut-off Die Blade	1	Y
20	634431002	634431002	Rear Plunger Retainer	1	Y
7	11-24-1067	4996-4	Cut-Off Plunger Spring	2	
8	11-40-4039	8302-5	Front Plunger Striker	1	
9	634430021	634430021	Lower Tooling Key	1	
10	634436003	634436003	Rear Cover	1	
11	11-18-4083	60707-8	Front Cover	1	
13	638008503	638008503	Wire Stop	1	
15	638008500	638008500	T2 Terminator	1	
32	638008502	638008502	Rear Plunger Striker	1	
36	634432106	634432106	Front Spacer	1	
38	11-40-4382	8341-8	Shank	1	
42	11-17-0022	1739-21	Hold Down Spring	1	
70	638504170	638504170	Tool Kit (All "Y" Items)	0	

## NOTES

1. We recommend an extra perishable tooling kit be maintained at your facility.
2. Verify tooling alignment by manually cycling the press and Terminator before crimping under power.
3. Slugs , Terminals, Dirt and Oil should be kept clear of work area.
4. This Terminator should only be used in a Molex TM42, TM40, or 3BF Press with a BaseUnit adaptor.
5. **\*\* CAUTION\*\*** To prevent injury never operate this Terminator without the guarding supplied with the TM42 , TM40, or 3BF Press / Base Unit.
6. Wear safety glasses at all times.

# ASSEMBLY DRAWING

The drawing below is a generic drawing representation. Some detail may not be shown. The T2 Terminator assembly and parts list can be found in the T2 Terminator manual.

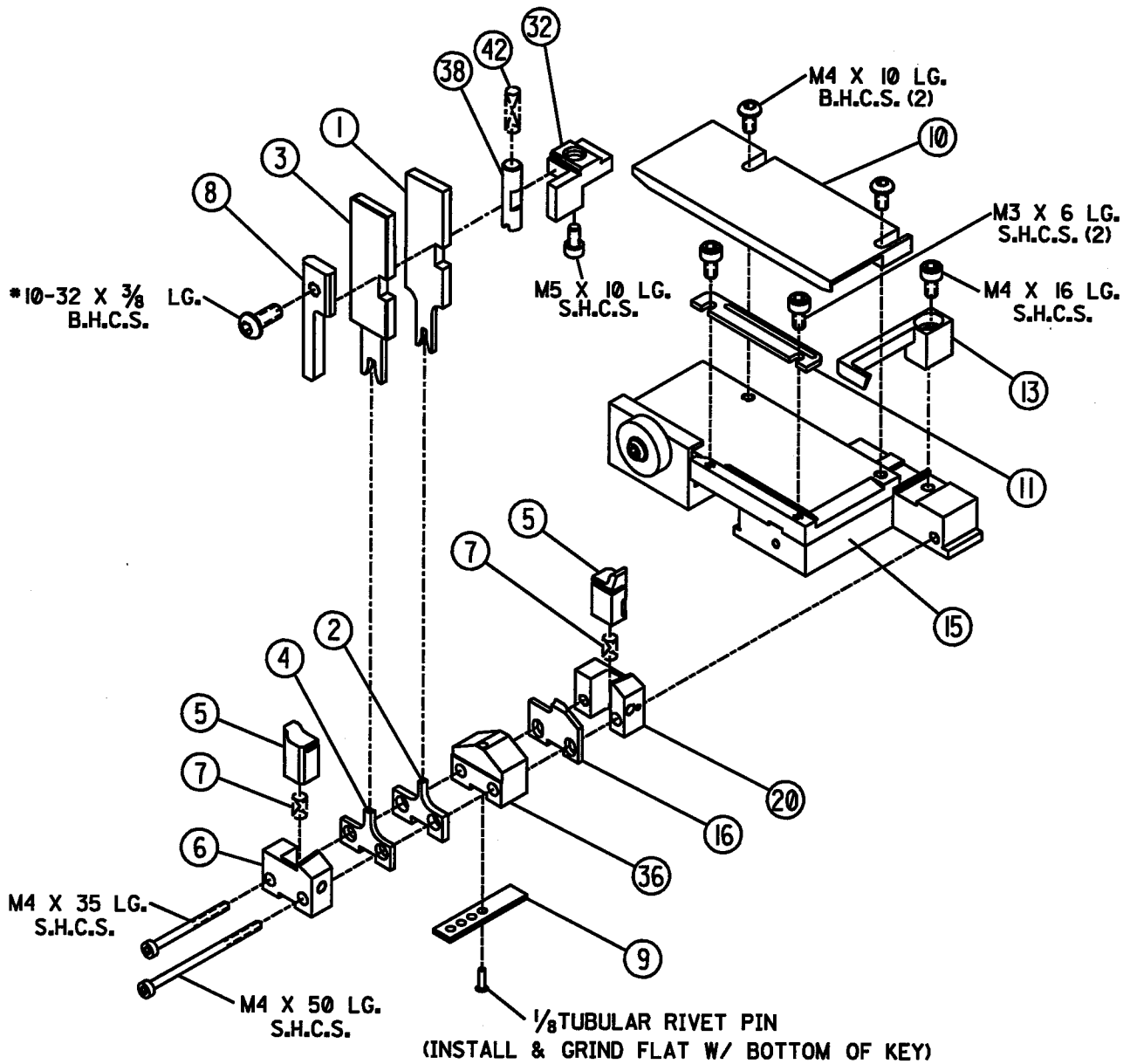

## Note

Depending on the press vintage a feed finger assembly is supplied with the T2 Terminator.

1. To remove the existing feed finger assembly loosen the M4 x 10 mm set screw in the feed lever.
2. Select T2 Feed finger assembly from Terminator box
3. Insert a screwdriver into to slot behind the feed lever and force the 12 mm spring to the right.
4. Slide the T2 feed finger shaft for TM42 (11-40-5307) or (11-40-0123) for TM40 /Base Unit into the feed lever and to the left of the 12 mm spring.
5. Release the 12 mm spring.
6. Position feed finger for selected product. (Ref fig 5.1 T2 Manual)

### TM42 Press

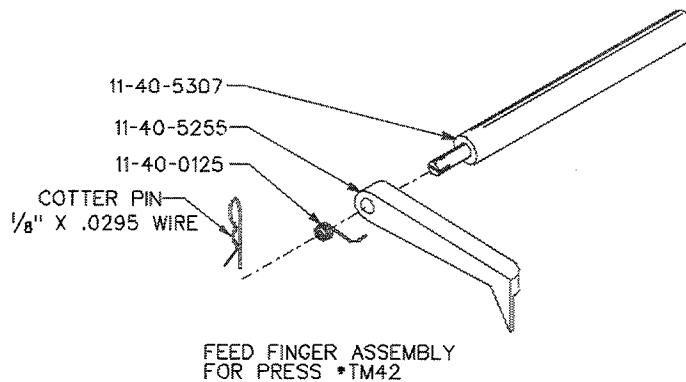

### TM40 Press & BaseUnit & Adaptor

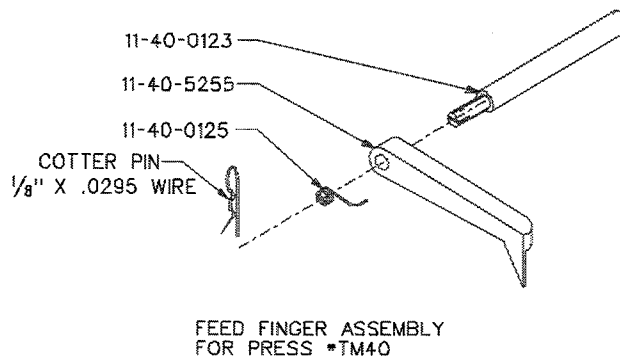

# Mouser Electronics

Authorized Distributor

Click to View Pricing, Inventory, Delivery & Lifecycle Information:

[Molex:](#)

[63850-4170](#)