

Specifications:

Resonant Frequency (Hz)	500 ~ 7000
Impedance (Ω)	8 ± 2
Input Power (Watts RMS)	30
Operating Temperature ($^{\circ}\text{C}$)	-20 ~ +70
Storage Temperature ($^{\circ}\text{C}$)	-30 ~ +80
Housing	ABS 757 UL94HB plastic resin (Color: White)
Leading Wire	20 AWG (White, White & Red)
Weight (Grams)	100
Locations	For indoor/outdoor use
Options	For other options contact factory

Dimensions: (units: mm)**ROHS Compliant**

Frequency Response:

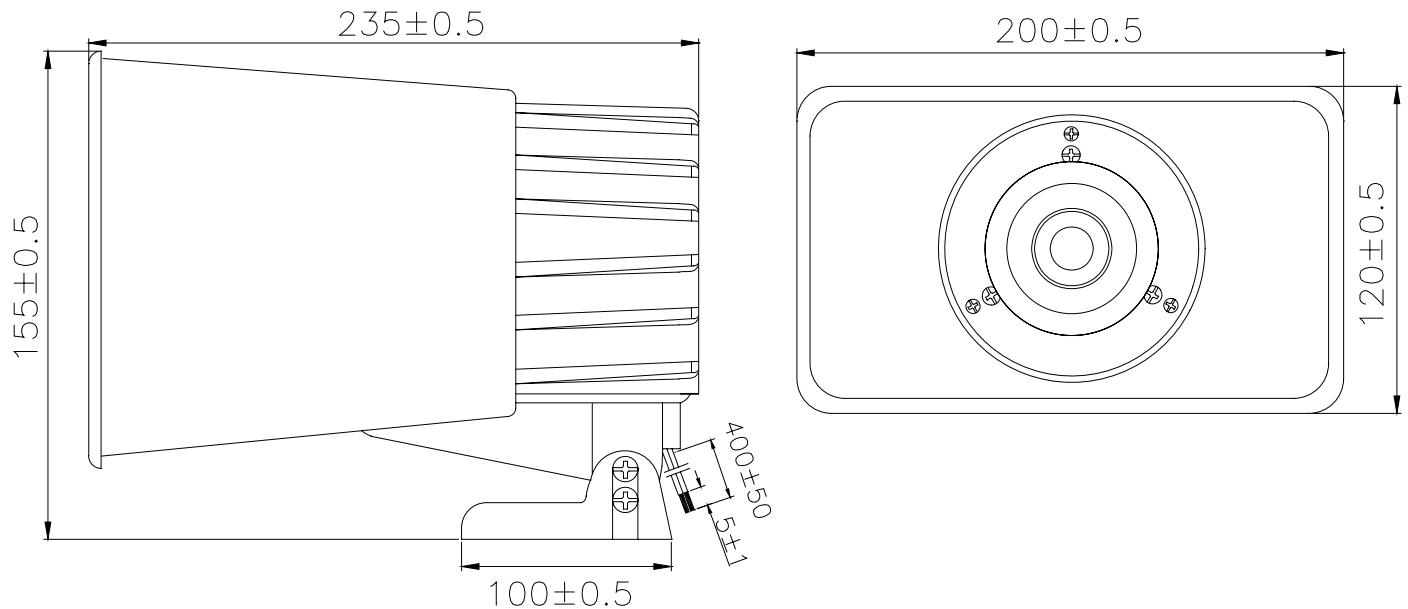

Mouser Electronics

Authorized Distributor

Click to View Pricing, Inventory, Delivery & Lifecycle Information:

[Mallory Sonalert:](#)

[PH-150Q](#)