

LOC	DIST	REVISIONS				
CM	0	REV	DESCRIPTION	DATE	BY	APPV
E1	REVISED PER ECR-15-007038			28SEP2015	NK	PQ

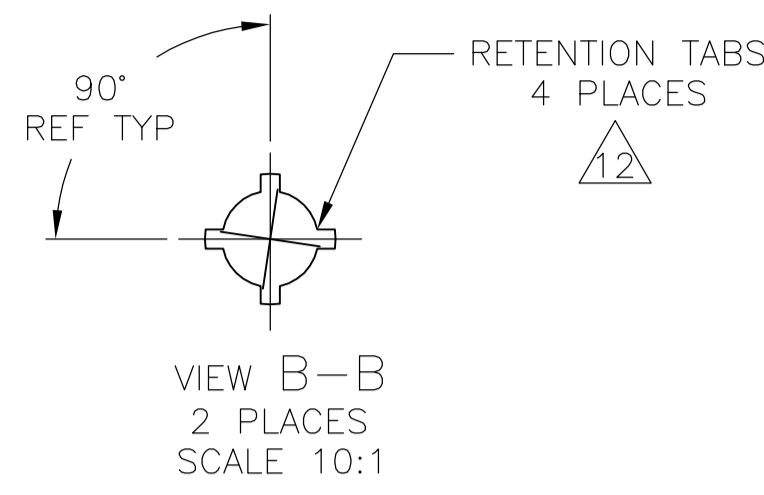

- 1 MATERIAL:
HOUSING - THERMOPLASTIC POLYESTER, GLASS FILLED, UL94-0.
POST - COPPER ALLOY
- 2 FINISH:
HOUSING - BLACK
POST - SEE NOTES 13 AND 14.
- 3 POST TO WITHSTAND 3LBS (16N) MIN AXIAL FORCE IN THIS DIRECTION WITHOUT DISLODGING.
- 4 APPLIES AT -A-.
- 5 APPLIES WHEN HEADER IS STRAIGHT.
- 6 PLASTIC PROJECTIONS PERMITTED IN THIS ZONE.
- 7 COORDINATE DIMENSIONS APPLIES FROM CENTER OF ACTUAL FEATURE.
- 8 SOLDER SIDE OF BOARD IS SHOWN.
- 9 POST SOLDERTAIL MUST COMPLY WITH AMP SOLDERABILITY SPEC 109-11-2.
- 10 LATCH DETENT FEATURE APPEARS 1 PLACE ON EACH END OF PART (MAX OF 2 PER PART) ON ALL POSITIONS 4 THRU 12. THE LATCH APPEARS ONLY ONE PLACE ON 2 & 3 POSITION PARTS.
- 11 DIMENSIONS IN BRACKETS ARE IN INCHES.
- 12 THE RETENTION TABS PROVIDE A ONE TIME INTERFERENCE FIT IN THE 1.63 [.064] DIAMETER P.C. BOARD HOLE FOR HEADER ASSEMBLY RETENTION DURING SOLDERING. FOUR TABS PER PEG, TWO PEGS PER HEADER ASSEMBLY (ONE PEG ONLY FOR -2 POSITION SIZE).
- 13 MATTE TIN PLATE 0.00381 - 0.00889 [.000150 - .000350] THICK, OVER NICKEL UNDERPLATE 0.00127 [.000050] MIN THICK.
- 14 MATTE TIN PLATE 0.00381 - 0.00889 [.000150 - .000350] THICK, OVER NICKEL UNDERPLATE 0.00127 [.000050] MIN THICK.
- 15 OBSOLETE PARTS: OBSOLETE CIS STREAMLINING PER D.RENAUD/D.SINISI

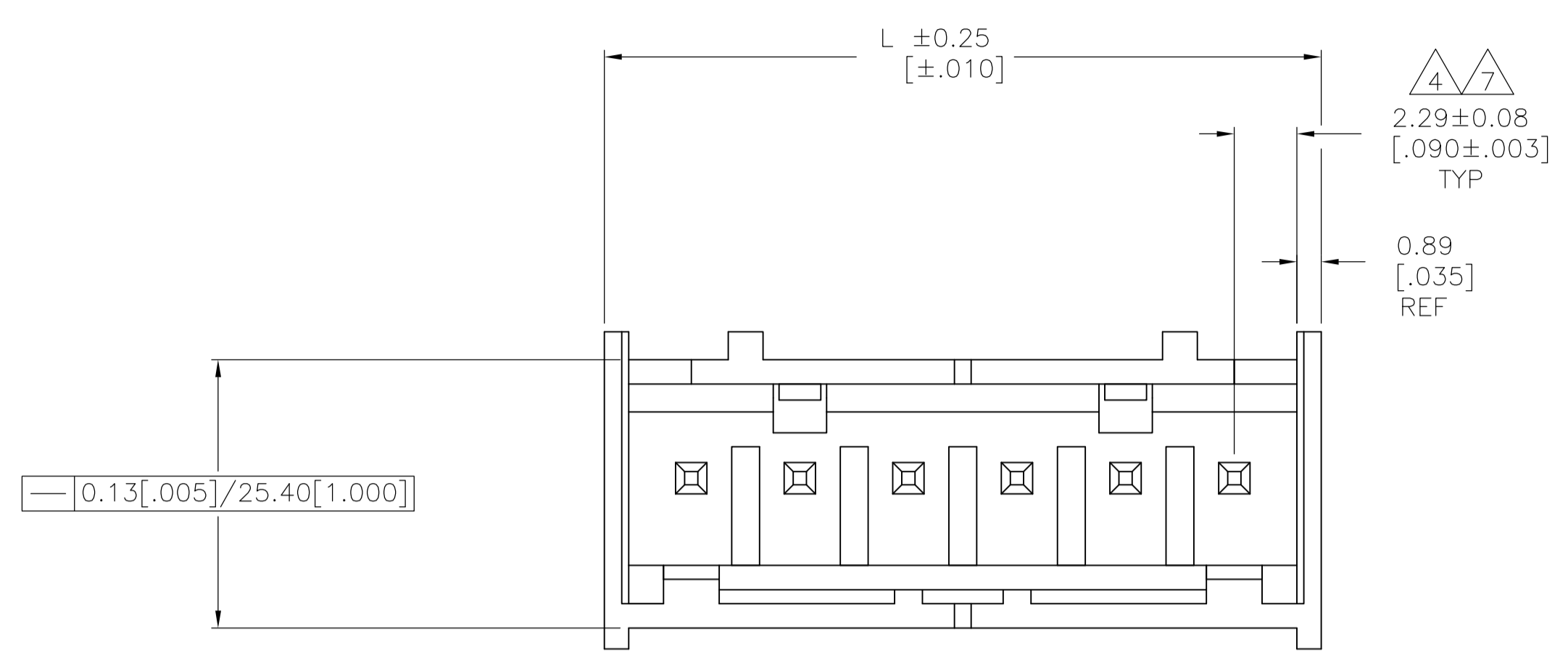
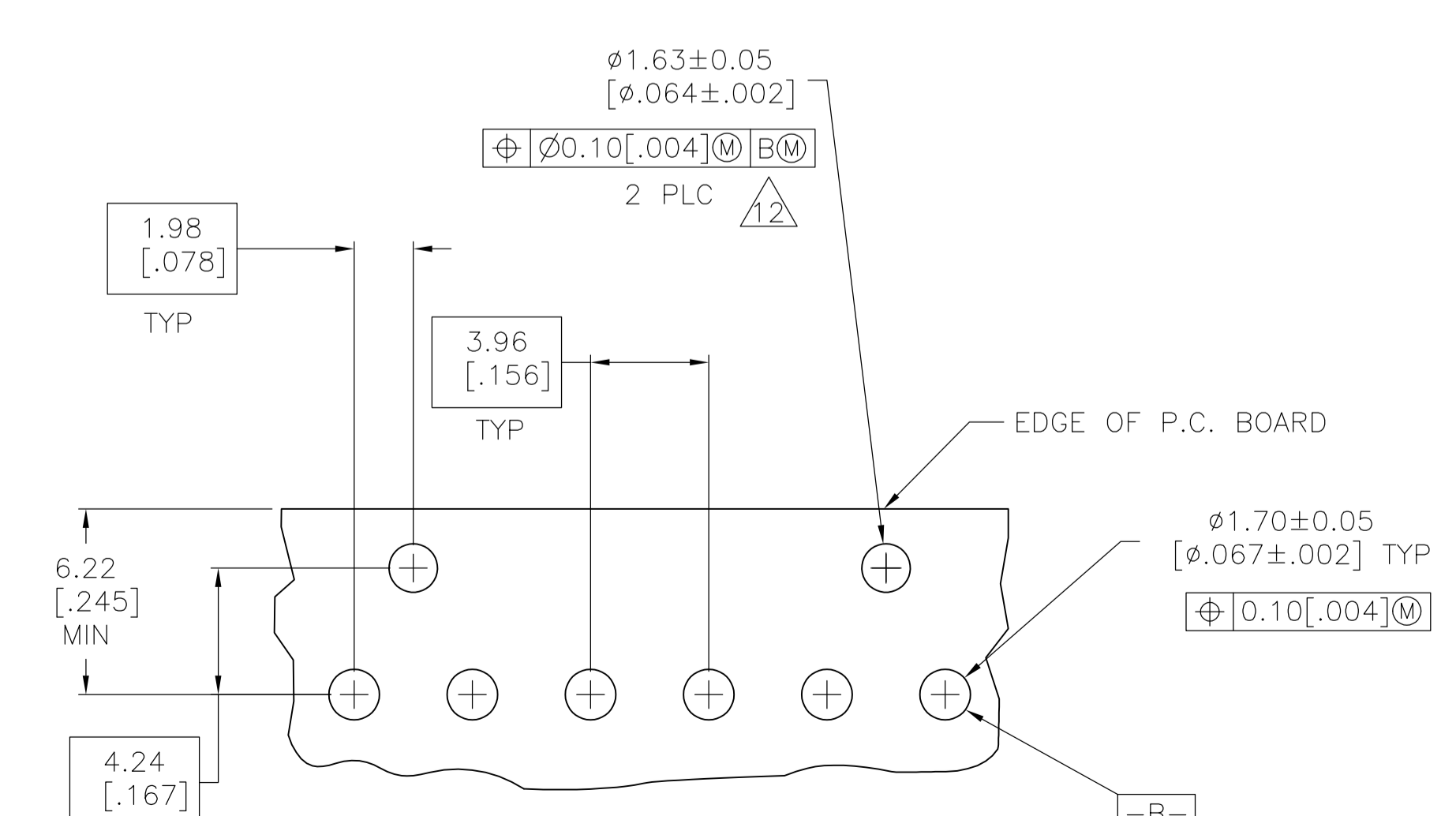
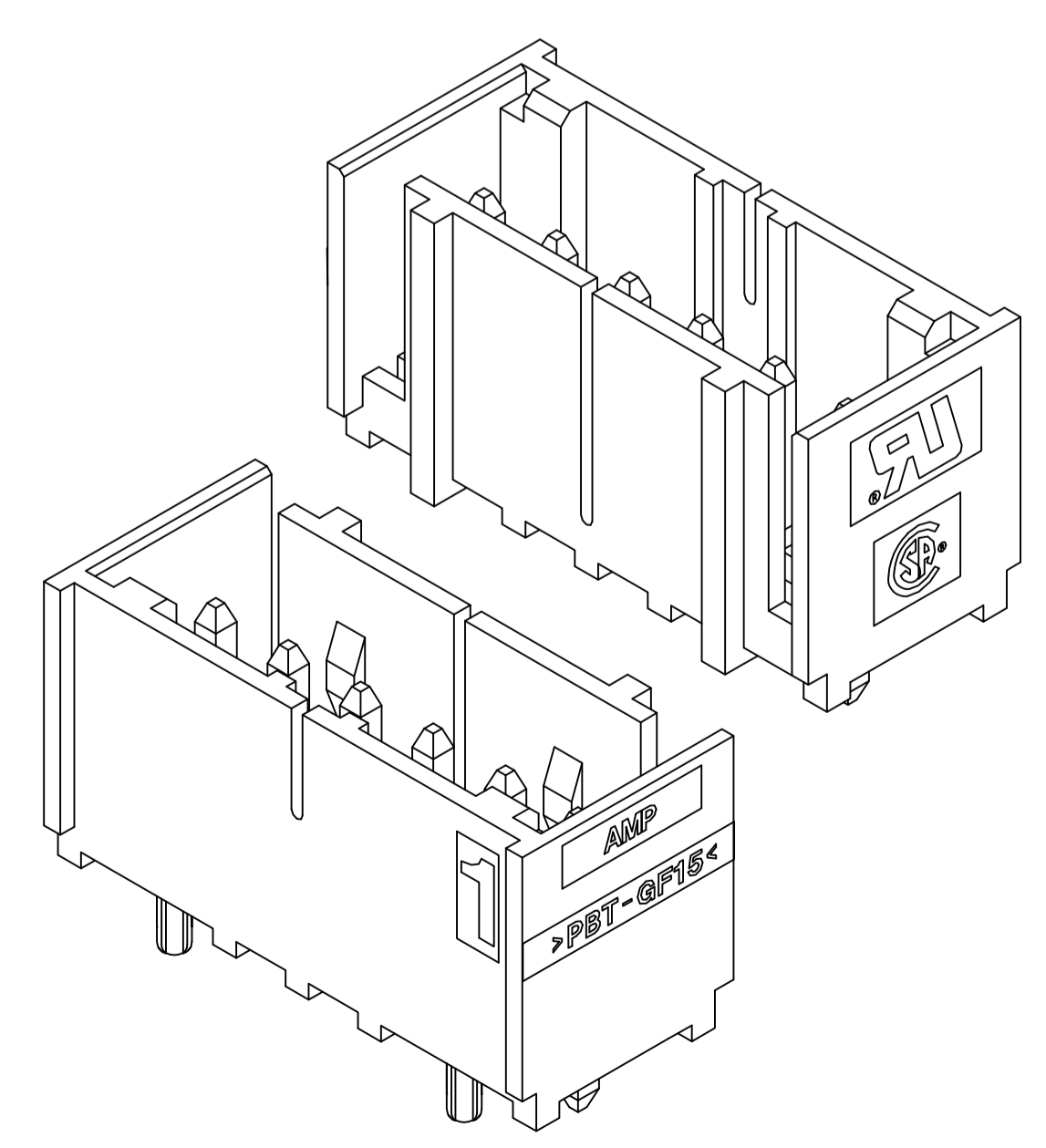
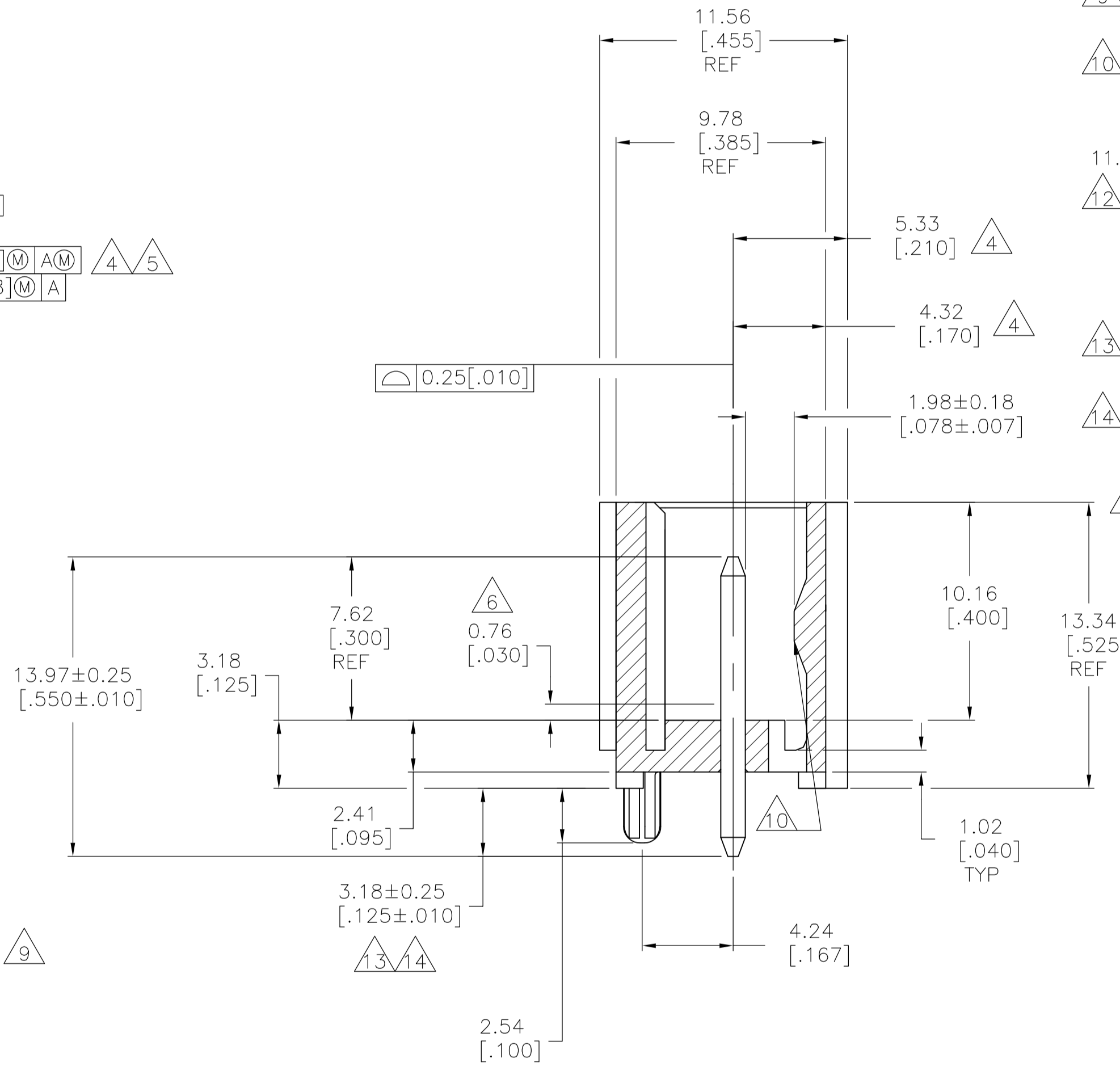
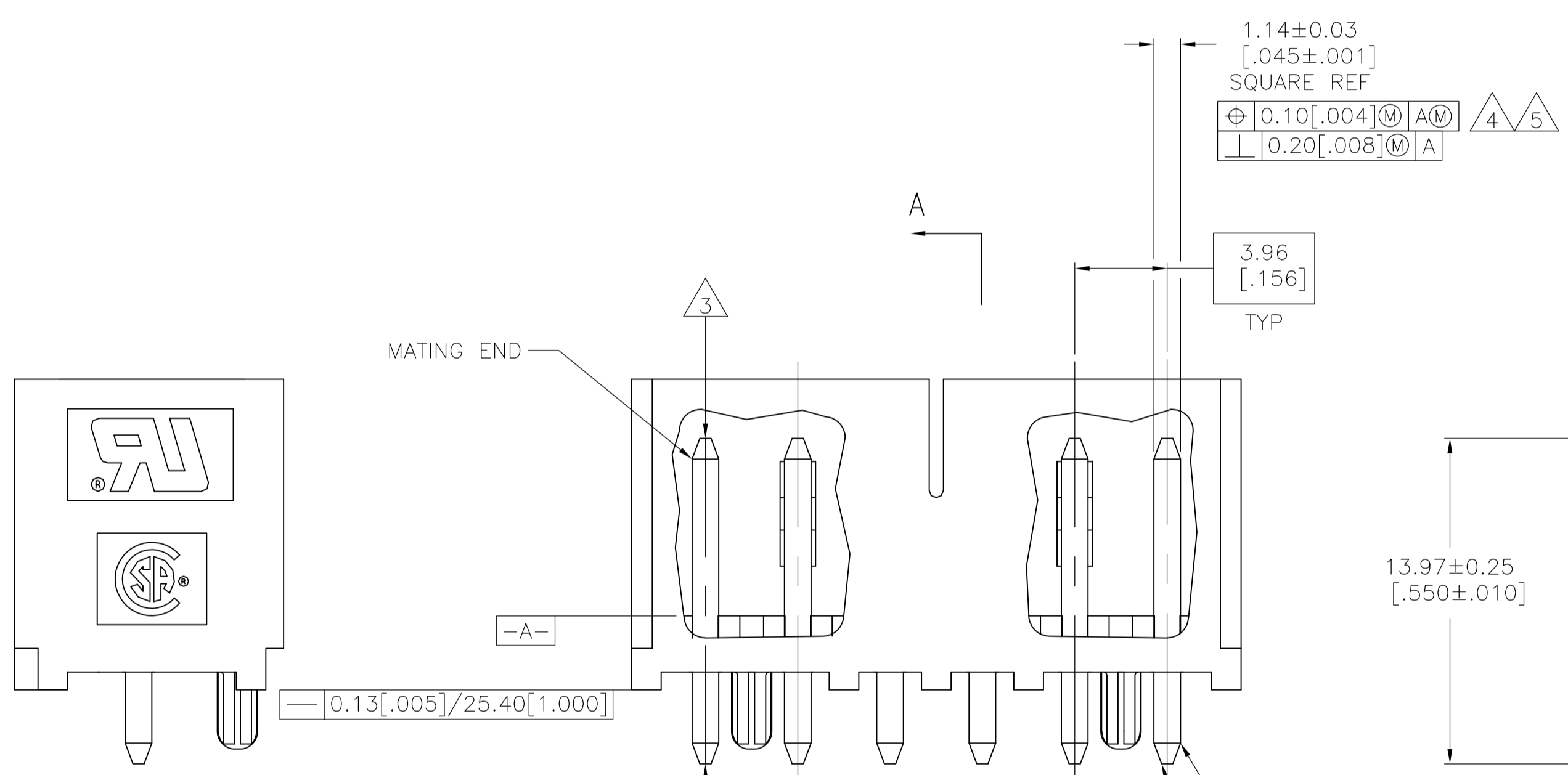

- 13 SUPERCEDED BY 3-647127-2
- 13 SUPERCEDED BY 3-647127-1
- 13 SUPERCEDED BY 3-647127-0
- 13 SUPERCEDED BY 2-647127-9
- 13 SUPERCEDED BY 2-647127-8
- 13 SUPERCEDED BY 2-647127-7
- 13 SUPERCEDED BY 2-647127-6
- 13 OBSOLETE
- 13 SUPERCEDED BY 2-647127-4
- 13 OBSOLETE
- 13 OBSOLETE

14	49.94	1.966	12	3-647127-2
	45.97	1.810	11	3-647127-1
	42.01	1.654	10	3-647127-0
	38.05	1.498	9	2-647127-9
	34.09	1.342	8	2-647127-8
	30.12	1.186	7	2-647127-7
	26.16	1.030	6	2-647127-6
	22.20	.874	5	2-647127-5
	18.24	.718	4	2-647127-4
	14.27	.562	3	2-647127-3
	10.31	.406	2	2-647127-2
	49.94	1.966	12	1-647127-2
	45.97	1.810	11	1-647127-1
	42.01	1.654	10	1-647127-0
	38.05	1.498	9	-647127-9
	34.09	1.342	8	-647127-8
	30.12	1.186	7	-647127-7
	26.16	1.030	6	-647127-6
	22.20	.874	5	-647127-5
	18.24	.718	4	-647127-4
	14.27	.562	3	-647127-3
	10.31	.406	2	-647127-2

DIMENSIONS:		TOLERANCES UNLESS OTHERWISE SPECIFIED:		DIN B. LEWIS 17JUN98	
mm	[INCHES]	0 PLC	±	CMK	17JUN98
		1 PLC	±	R SWING	
		2 PLC	±	APVD D. CLARK 17JUN98	
		3 PLC	±	NAME	
		4 PLC	±	PRODUCT SPEC	
		ANGLES	±	APPLICATION SPEC	
			±	SIZE	
			±	CODE	
			±	DRAWING NO	
			±	RESTRICTED TO	
			±	WEIGHT	
			±	A1 00779	
			±	SCALE	
			±	5:1	
			±	SHEET	
			±	1 of 1	
			±	REV	
			±	E1	

Mouser Electronics

Authorized Distributor

Click to View Pricing, Inventory, Delivery & Lifecycle Information:

[TE Connectivity:](#)

[2-647127-6](#)