

LOC		DIST		REVISIONS			
P	LTR	DESCRIPTION	DATE	DMN	APVD		
T		REV PER ECO-15-016251	13NOV15	KG	CD		

- THIS RECEPTACLE WILL MATE WITH ANY 9C4, SIZE 3 PLUG IN AMPLIMITE SERIES.
- MAXIMUM WIRE INSULATION TO BE USED WITH THIS RECEPTACLE IS $\phi.072$.
- THIS CONNECTOR ACCEPTS (4) POWER 8, OR COAX SOCKET CONTACTS IN POSITIONS A1 THRU A4, PURCHASED SEPARATELY. WILL NOT ACCEPT WILL NOT ACCEPT RIGHT ANGLE COAX.
- THIS CONNECTOR ACCEPTS SIZE 20 SOCKET SIGNAL CONTACTS IN POSITIONS 1 THRU 5, PURCHASED SEPARATELY.

- 5 UL/CSA DESIGNATION STAMPED IN THIS AREA, OPTIONAL.
- 6 STEEL PER ASTM-A-109.
- 7 BRASS PER MIL-C-50 AND ASTM-B-36 UNS NO. C26000.
- 8 CADMIUM PLATED PER QQ-P-416, TYPE II, CLASS 2 OVER COPPER PER MIL-C-14550, CLASS IV.
- 9 GOLD PLATED PER MIL-G-45204 TYPE II, GRADE C, CLASS 1 OVER COPPER PER MIL-C-14550, CLASS IV.
- 10 FINISH: TIN PER ASTM-B-545 .000400 MIN THK OVER COPPER PER AMS2418 .000050 MIN THK.
- 11 FINISH: ZINC PLATE PER ASTM-B-633 .000200-.000400 THK WITH SUPPLEMENTARY CHROMATE (Cr3+).

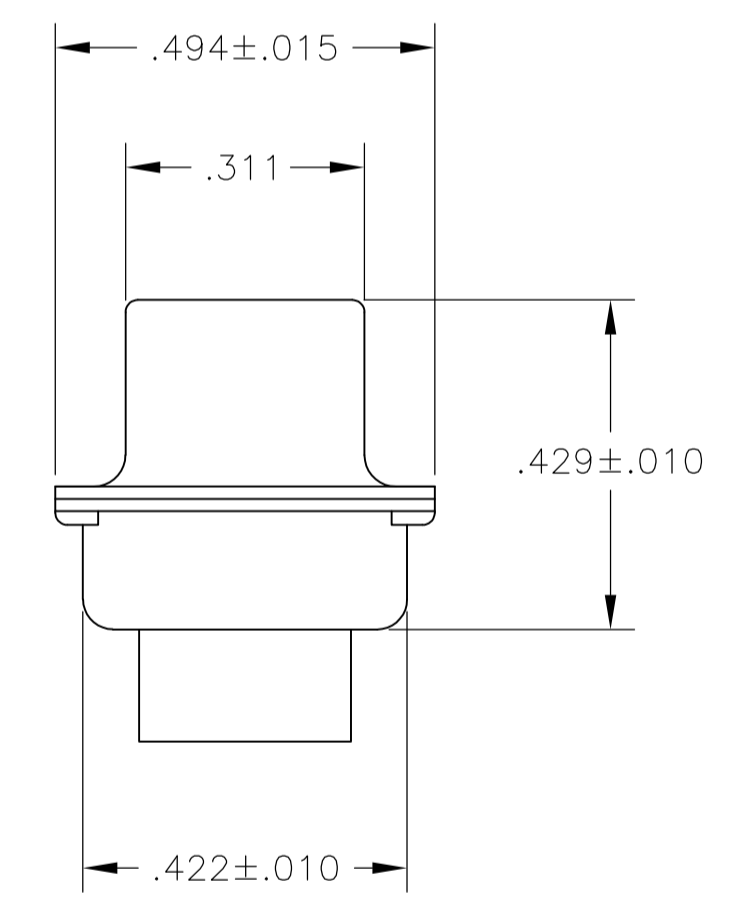
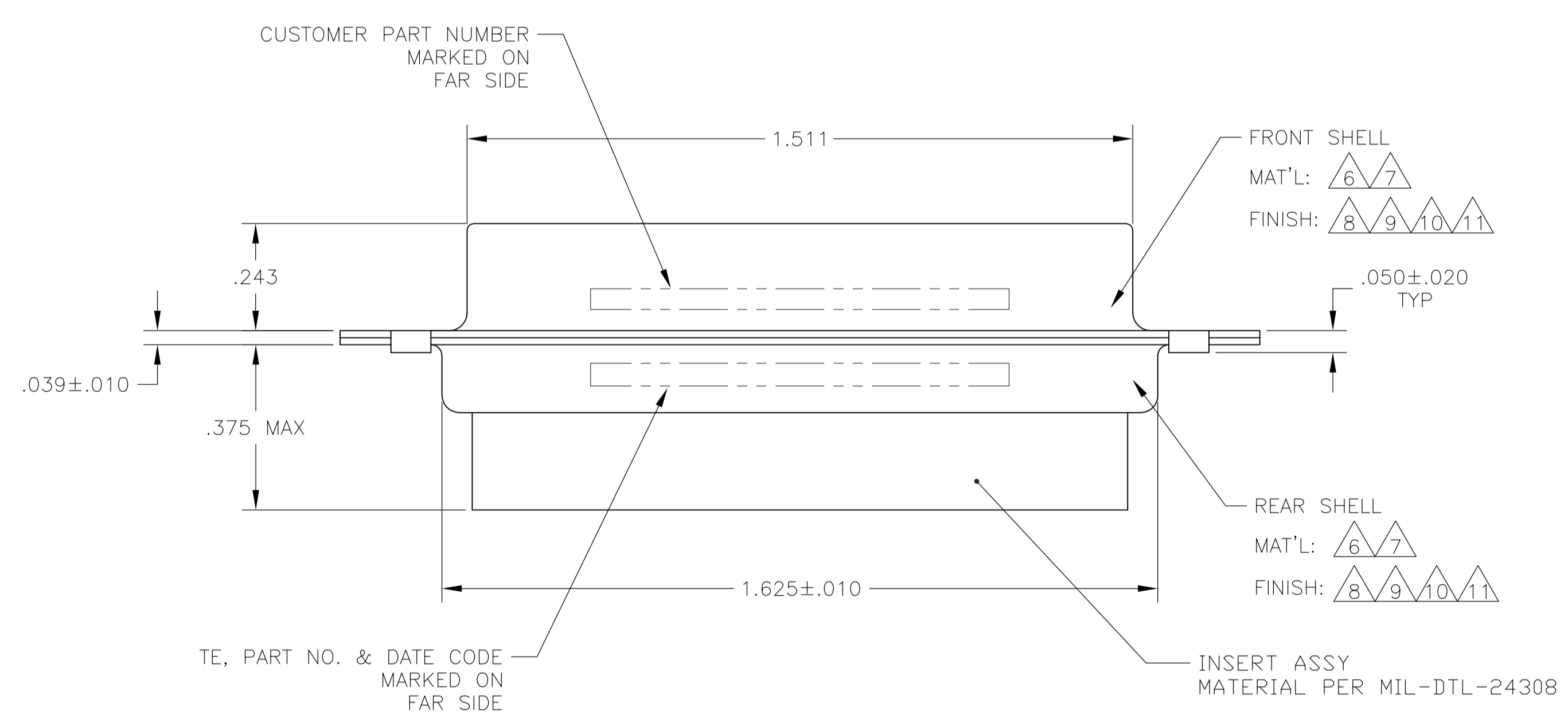
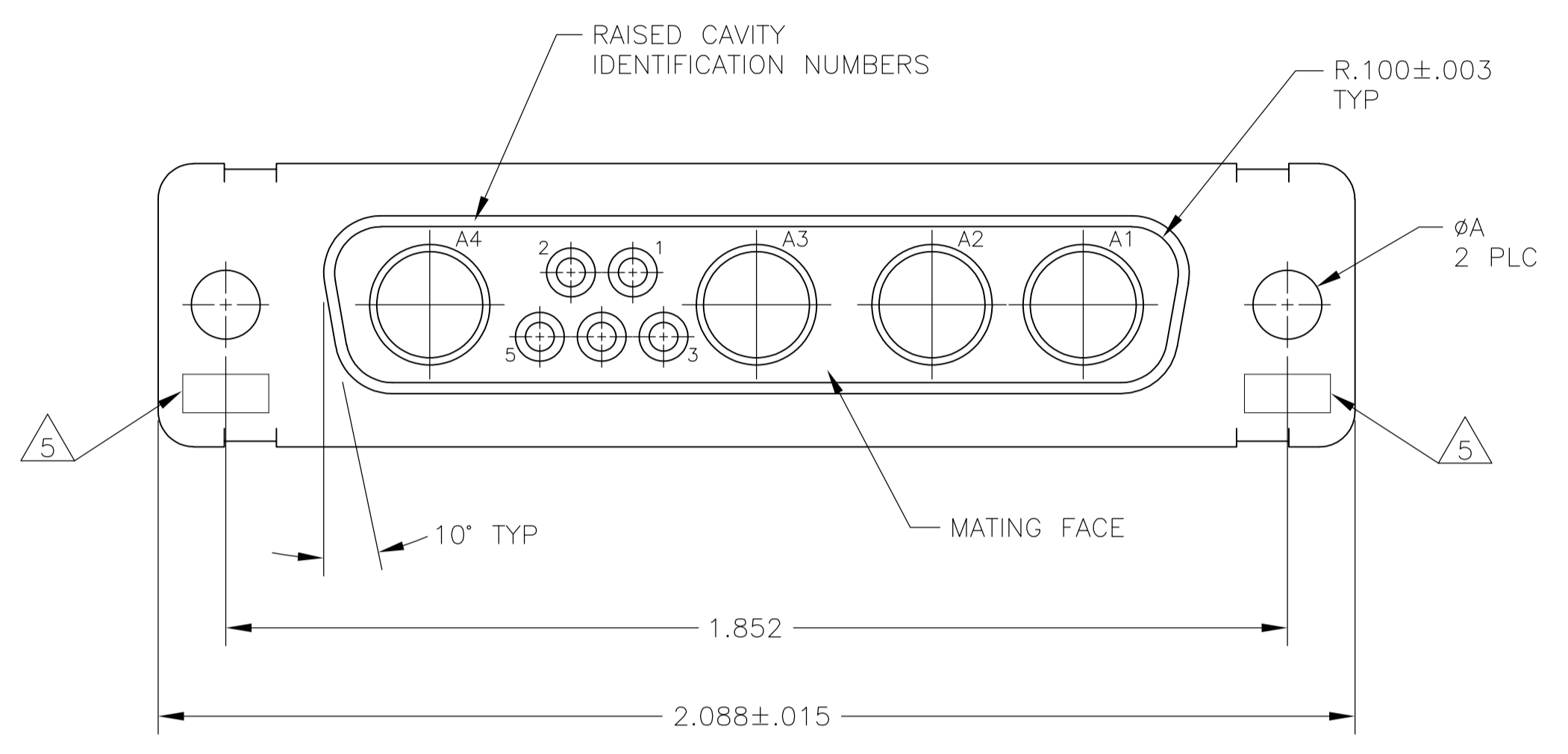

6 8	.120	T5935-0103-008	212502-7
6 10	.120	-	5-212502-5
6 11	.120	-	5-212502-1
7 9	.120	B010942-0018	212502-6
6 10	.120	-	212502-5
6 10	.154	-	212502-4
7 9	.154	311P405-11S-B-15	212502-3
7 9	.120	311P405-11S-B-12	212502-2
6 8	.120	-	212502-1
REMARKS	ϕA	CUSTOMER P/N	PART NO.

THIS DRAWING IS A CONTROLLED DOCUMENT.

APPROVED: A. EMADI
 DATE: 29JAN88

DESIGNED: C.C. THOMAS
 DATE: 27JAN88

TE Connectivity

RECEPTACLE ASSEMBLY
 AMPLIMITE 9C4
 SIZE 3, SERIES 109, COAX MIX

SIZE: A1
 CAGE CODE: 00779
 DRAWING NO: 212502

SCALE: 4:1
 SHEET: 1 OF 1
 REV: T

WEIGHT: --
 MATERIAL: --
 FINISH: --

TOLERANCES UNLESS OTHERWISE SPECIFIED:
 0 PLC ± --
 1 PLC ± --
 2 PLC ± --
 3 PLC ± .005(0.13)
 4 PLC ± --
 ANGLES ± # 0°30'

CUSTOMER DRAWING

Mouser Electronics

Authorized Distributor

Click to View Pricing, Inventory, Delivery & Lifecycle Information:

[TE Connectivity:](#)

[212502-1](#)