

REV.	DATE	DESCRIPTION
NC	05/24/04	INITIAL RELEASE

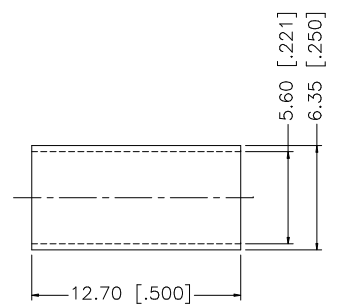
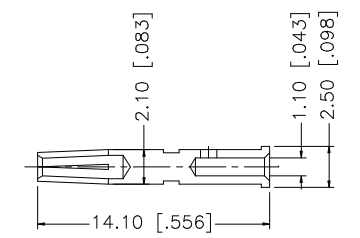
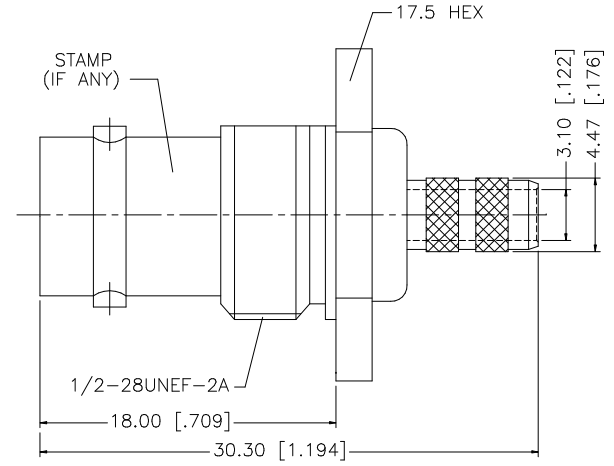
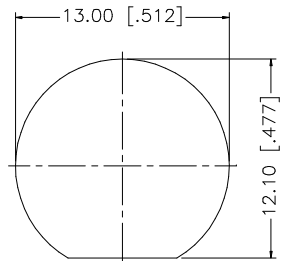
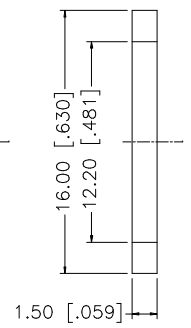
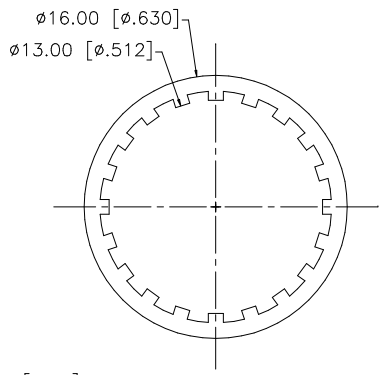
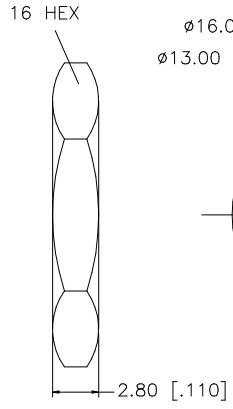
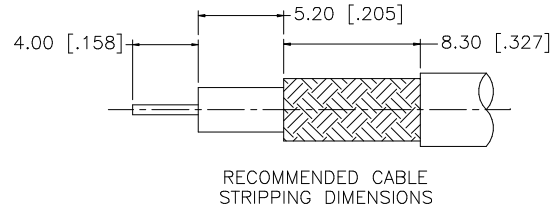

- NOTE:
1. CRIMPED FERRULE  
HEX CRIMP SIZE .213"
  2. CRIMPED CONTACT PIN  
HEX CRIMP SIZE .068"

QTY	DESCRIPTION	MATERIAL	FINISH
1	BODY/HOUSING	BRASS	NICKEL
1	INSULATOR	TEFLON	NATURAL
2	CONTACT PIN	PHOS. BRONZE	GOLD
3	GASKET	RUBBER	RED
4	LOCK WASHER	BRASS	NICKEL
5	HEX NUT	BRASS	NICKEL
6	FERRULE	COPPER	NICKEL
8			

UNLESS OTHERWISE SPECIFIED DIMENSIONS ARE IN MILLIMETERS. DIMENSIONS IN [ ] ARE IN INCHES AND FOR CUSTOMER REFERENCE ONLY.

UNLESS OTHERWISE SPECIFIED TOLERANCES FOR MILLIMETERS ARE:  
0.5 - 8mm ± 0.20mm  
8 - 30mm ± 0.40mm  
30 - 120mm ± 0.50mm

UNLESS OTHERWISE SPECIFIED TOLERANCES FOR INCHES ARE:  
.020 - .315 = ± 0.007"  
.315 - 1.180 = ± 0.015"  
1.180 - 4.724 = ± 0.020"

DO NOT SCALE DRAWING

APPROVALS	DATE
DRAWN G.R.S.	05/24/04
CHECKED	
ISSUED	
SHEET 1 OF 1	
CAD FILE C:/112/112505.DWG	

**Amphenol Connex**

PART DESCRIPTION  
**BNC BULKHEAD CRIMP JACK**  
(FOR RG-55/U, 142A/U, 223/U, 400/U CABLE)

PART NO. **112505**

DWG. NO. 112505.DWG	REV. NC	SIZE A	SCALE NA
---------------------	---------	--------	----------

# Mouser Electronics

Authorized Distributor

Click to View Pricing, Inventory, Delivery & Lifecycle Information:

[Amphenol:](#)

[112505](#)