

4

3

2

1

THIS DRAWING IS UNPUBLISHED. RELEASED FOR PUBLICATION 20  
 © COPYRIGHT 20 BY - ALL RIGHTS RESERVED.

| LOC |     | DIST        |                           | REVISIONS |           |      |    |
|-----|-----|-------------|---------------------------|-----------|-----------|------|----|
| P   | LTR | DESCRIPTION |                           | DATE      | DWN       | APVD |    |
| AF  | 50  | A2          | REVISED PER ECR-15-006219 |           | 30APR2015 | NK   | JR |
|     |     |             |                           |           |           |      |    |
|     |     |             |                           |           |           |      |    |

1 MATES WITH CORRESPONDING PLUG HOUSING  
 PART NUMBER X-1969540-X.

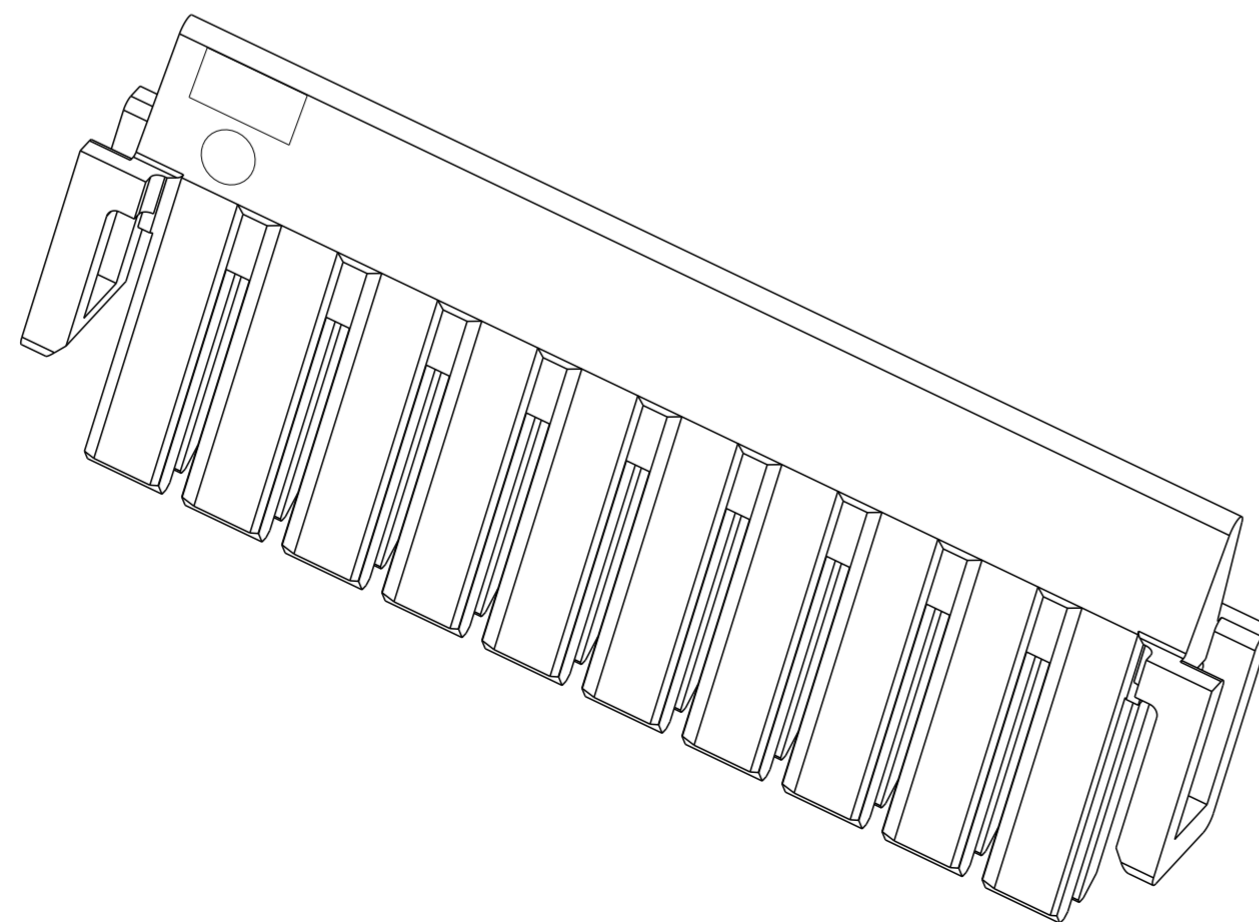
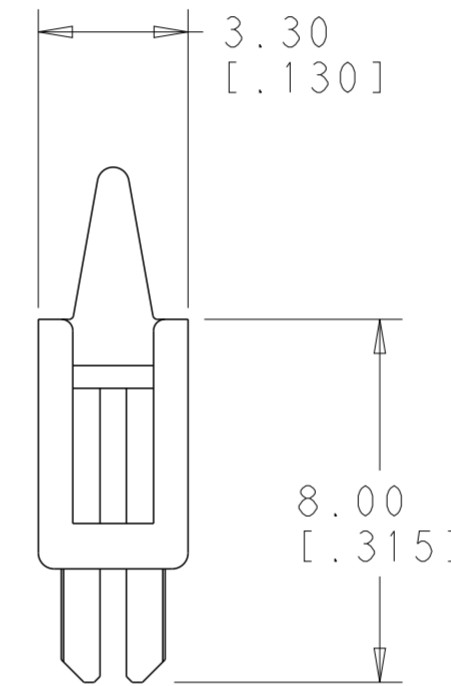
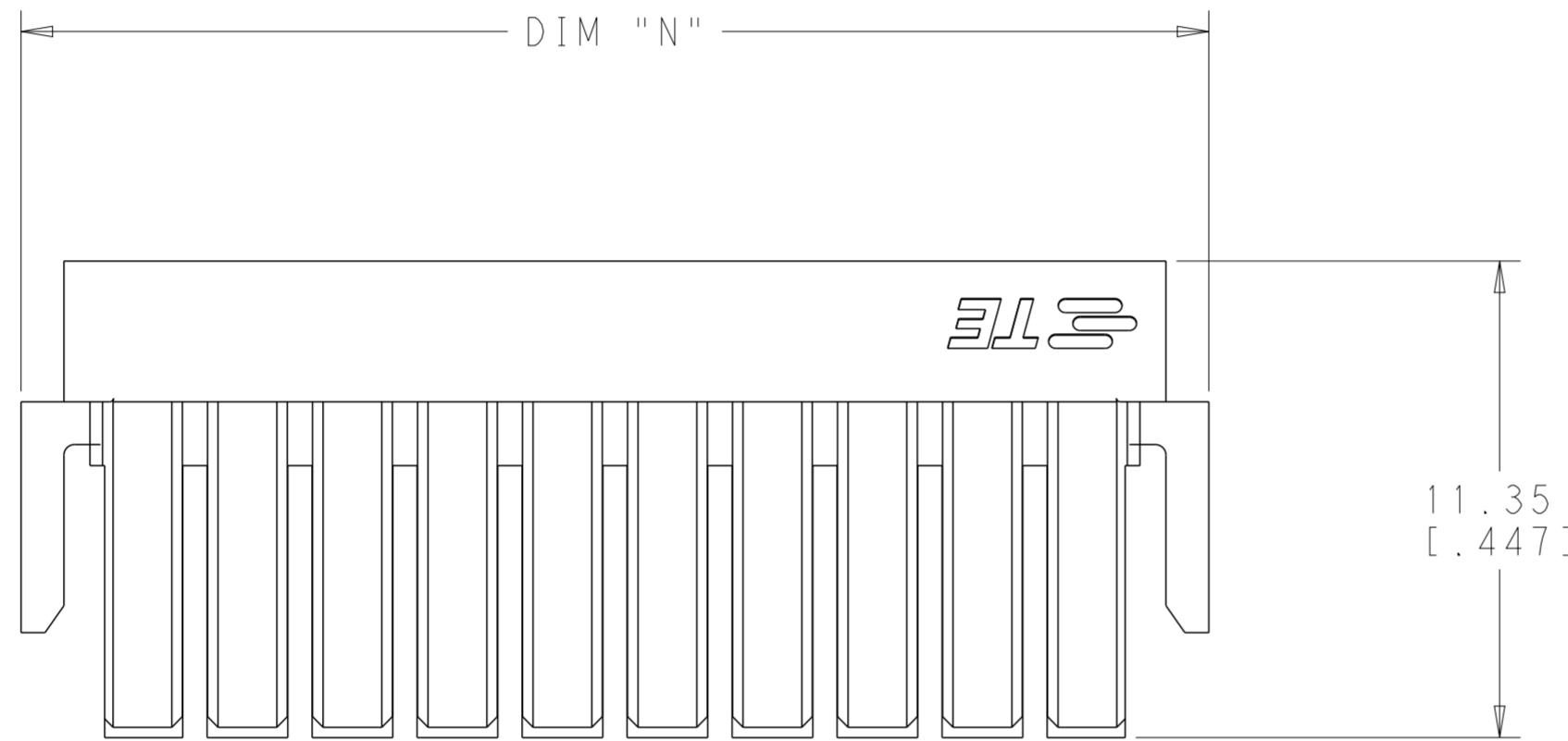
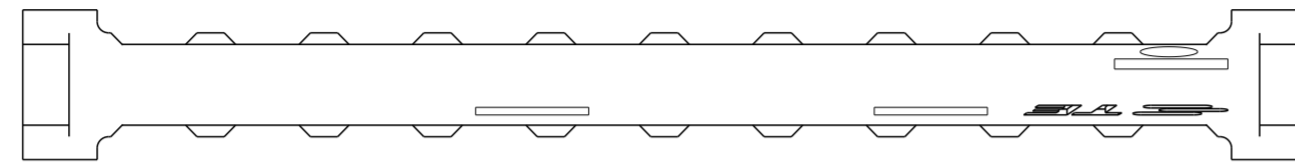

|               |             |
|---------------|-------------|
| 53.28 [2.098] | 4-1969541-0 |
| 50.78 [1.999] | 3-1969541-8 |
| 48.28 [1.901] | 3-1969541-6 |
| 45.78 [1.802] | 3-1969541-4 |
| 43.28 [1.704] | 3-1969541-2 |
| 40.78 [1.605] | 3-1969541-0 |
| 38.28 [1.507] | 2-1969541-8 |
| 35.78 [1.409] | 2-1969541-6 |
| 33.28 [1.310] | 2-1969541-4 |
| 30.78 [1.212] | 2-1969541-2 |
| 28.28 [1.113] | 2-1969541-0 |
| 25.78 [1.015] | 1-1969541-8 |
| 23.28 [.916]  | 1-1969541-6 |
| 20.78 [.818]  | 1-1969541-4 |
| 18.28 [.720]  | 1-1969541-2 |
| 15.78 [.621]  | 1-1969541-0 |
| 13.28 [.523]  | 1969541-8   |
| DIM "N"       | PART NO.    |

|   |   |                  |               |               |   |
|---|---|------------------|---------------|---------------|---|
| THIS DRAWING IS A CONTROLLED DOCUMENT.  |   | DWN              | JR RUTH       | 21AUG2012     |  TE Connectivity |
| DIMENSIONS: mm [INCHES]   |   | CHK              | KURT RANDOLPH | 21AUG2012     |   |
| TOLERANCES UNLESS OTHERWISE SPECIFIED:  |   | APVD             | SAM MACE      | 21AUG2012     |   |
| 0 PLC ±<br>1 PLC ±<br>2 PLC ±0.13 [.005]<br>3 PLC ±<br>4 PLC ±<br>ANGLES ±1<br>FINISH |   | PRODUCT SPEC     | 108-2418      | NAME          |   |
| MATERIAL  | - | APPLICATION SPEC | 114-13315     | SIZE          | A2  |
| - COLOR-BLACK   |   | WEIGHT           | -             | CAGE CODE     | 00779   |
| Customer Drawing  |   | DRAWING NO       |               | RESTRICTED TO | -   |
| SCALE 5:1   |   | SHEET 1 OF 1     |               | REV           | A2  |

# Mouser Electronics

Authorized Distributor

Click to View Pricing, Inventory, Delivery & Lifecycle Information:

[TE Connectivity:](#)

[3-1969541-0](#)