

Features

- Dual RF input for antenna space and frequency diversity, LNA cascading or differential feeding
 - Fully integrated PLL-based synthesizer
 - 2nd mixer with image rejection
 - Reception of ASK or FSK modulated signals
 - Wide operating voltage and temperature ranges
 - Very low standby current consumption
 - Low operating current consumption
 - External IF filters 455kHz or 10.7MHz
 - Internal FSK demodulator
 - Average or peak detection data slicer mode
 - RSSI output with high dynamic range for RF level indication
 - Output noise cancellation filter
 - MCU clock output
 - High over-all frequency accuracy
-

Ordering Information

Part No. (see paragraph 4)

EVB71120-315-C
EVB71120-433-C

EVB71120-868-C
EVB71120-915-C

Note 1: Peak detection mode, IF2 selection = 10.7MHz is default population.

Application Examples

- General digital and analog RF receivers at 300 to 930MHz
- Tire pressure monitoring systems (TPMS)
- Remote keyless entry (RKE)
- Low power telemetry systems
- Alarm and security systems
- Active RFID tags
- Remote controls
- Garage door openers
- Home and building automation

General Description

The MLX71120 is a multi-band, single-channel RF receiver based on a double-conversion super-heterodyne architecture. It can receive FSK and ASK modulated signals. The IC is designed for general purpose applications for example in the European bands at 433MHz and 868MHz or for similar applications in North America or Asia, e.g. at 315MHz or 915MHz. It is also well-suited for narrow-band applications according to the ARIB STD-T67 standard in the frequency range 426MHz to 470MHz.

The receiver's extended temperature and supply voltage ranges make the device a perfect fit for automotive or similar applications where harsh environmental conditions are expected.

Document Content

1	Theory of Operation	3
1.1	General	3
1.2	Technical Data Overview	3
1.3	Block Diagram	4
1.4	Operating Modes	5
1.5	Frequency Range	5
1.6	LNA Selection	5
1.7	External IF2 Selection	5
1.8	Demodulation Selection	5
1.9	Data Slicer	5
2	Frequency Planning	6
2.1	Calculation of Frequency Settings	7
2.2	Standard Frequency Plans	8
2.3	433/868MHz Frequency Diversity	8
3	Dual-Channel Application Circuits for FSK & ASK Reception	9
3.1	Peak Detector Data Slicer	9
3.1.1	Component Arrangement Top Side (Peak Detection Data Slicer, IF2 = 10.7MHz)	10
3.1.2	Component Arrangement Top Side (Peak Detection Data Slicer, IF2 = 455kHz)	11
3.2	Averaging Data Slicer Configured for-Bi Phase Codes	12
3.2.1	Component Arrangement Top Side (Averaging Data Slicer, IF2 = 10.7MHz)	13
3.3	Component List for Dual-Channel Application	14
3.4	PCB Layouts for Antenna Space Diversity	15
4	Board Variants	15
5	Package Description	16
5.1	Soldering Information	16
6	Reliability Information	17
7	ESD Precautions	17
8	Disclaimer	18

1 Theory of Operation

1.1 General

The MLX71120 receiver architecture is based on a double-conversion super-heterodyne approach. The two LO signals are derived from an on-chip integer-N PLL frequency synthesizer. The PLL reference frequency is derived from a crystal (XTAL). As the first intermediate frequency (IF1) is very high, a reasonably high degree of image rejection is provided even without using an RF front-end filter. At applications asking for very high image rejections, cost-efficient RF front-end filtering can be realized by using a SAW filter in front of the LNA. The second mixer MIX2 is an image-reject mixer.

The receiver signal chain is setup by one (or two) low noise amplifier(s) (LNA1, LNA2), two down-conversion mixers (MIX1, MIX2) and an external IF filter with an on-chip amplifier (IFA). By choosing the required modulation via an FSK/ASK switch (at pin MODSEL), either the on-chip FSK demodulator (FSK DEMOD) or the RSSI-based ASK detector is selected. A second order data filter (OA1) and a data slicer (OA2) follow the demodulator. The data slicer threshold can be generated from the mean-value of the data stream or by means of the positive and negative peak detectors (PKDET+/-). A digital post-processing of the sliced data signal can be performed by a noise filter (NF) building block.

The dual LNA configuration can be used for antenna space diversity or antenna frequency diversity or to setup an LNA cascade (to further improve the input sensitivity). The two LNAs can also be setup to feed the RF signal differentially.

A sequencer circuit (SEQ) controls the timing during start-up. This is to reduce start-up time and to minimize power dissipation.

A clock output, which is a divide-by-8 version of the crystal oscillator signal, can be used to drive a microcontroller. The clock output is open drain and gets activated through a load connected to positive supply.

1.2 Technical Data Overview

- | | |
|------------------------------------------------------------------------------------------------------------------------------------------------------------------------------------------------------------------------------------------------------------------------------------------------------------------------------------------------------------------------------------------------------------------------------------------------------------------------------------------------------------------------------------------------------------------------------------------|---------------------------------------------------------------------------------------------------------------------------------------------------------------------------------------------------------------------------------------------------------------------------------------------------------------------------------------------------------------------------------------------------------------------------------------------------------------------------------------------------------------------------------------------------------------------------------------------|
| <ul style="list-style-type: none"> <input type="checkbox"/> Input frequency ranges: 300 to 470MHz
610 to 930MHz <input type="checkbox"/> Power supply range: 2.1 to 5.5V <input type="checkbox"/> Temperature range: -40 to +125°C <input type="checkbox"/> Shutdown current: 50 nA <input type="checkbox"/> Operating current: 6.5 to 8.1mA <input type="checkbox"/> Selectable IF2 frequency: 10.7MHz or 455kHz <input type="checkbox"/> FSK deviation range: ±10kHz to ±100kHz (WB)
±2kHz to ±10kHz (NB) | <ul style="list-style-type: none"> <input type="checkbox"/> Image rejection:
65dB 1st IF (with external RF front-end filter)
25dB 2nd IF (internal image rejection) <input type="checkbox"/> Maximum data rate: 50kps RZ (bi-phase) code,
100kps NRZ <input type="checkbox"/> Spurious emission: < -54dBm <input type="checkbox"/> Linear RSSI range: > 70dB <input type="checkbox"/> Crystal reference frequency: 16 to 27MHz <input type="checkbox"/> MCU clock frequency: 2.0 to 3.4 |
|------------------------------------------------------------------------------------------------------------------------------------------------------------------------------------------------------------------------------------------------------------------------------------------------------------------------------------------------------------------------------------------------------------------------------------------------------------------------------------------------------------------------------------------------------------------------------------------|---------------------------------------------------------------------------------------------------------------------------------------------------------------------------------------------------------------------------------------------------------------------------------------------------------------------------------------------------------------------------------------------------------------------------------------------------------------------------------------------------------------------------------------------------------------------------------------------|

<input type="checkbox"/> Input Sensitivity: at 4kbps NRZ, BER = 3·10 ⁻³						
		Frequency	315 MHz	433.92 MHz	868.3 MHz	915 MHz
FSK	wide band 180kHz BW, IF2=10.7MHz Δf = ±20kHz	-109dBm	-108dBm	-106dBm	-104dBm	
	narrow band 20kHz BW, IF2=455kHz Δf = ±5kHz	-114dBm	-112dBm	-111dBm	-109dBm	
ASK	wide band 180kHz BW, IF2=10.7MHz	-113dBm	-113dBm	-111dBm	-109dBm	

- Note:**
- Sensitivities given for RF input 1 (without SAW filter)
 - Sensitivity for RF input 2 is about 2 to 3dB worse (because of SAW filter loss)

1.3 Block Diagram

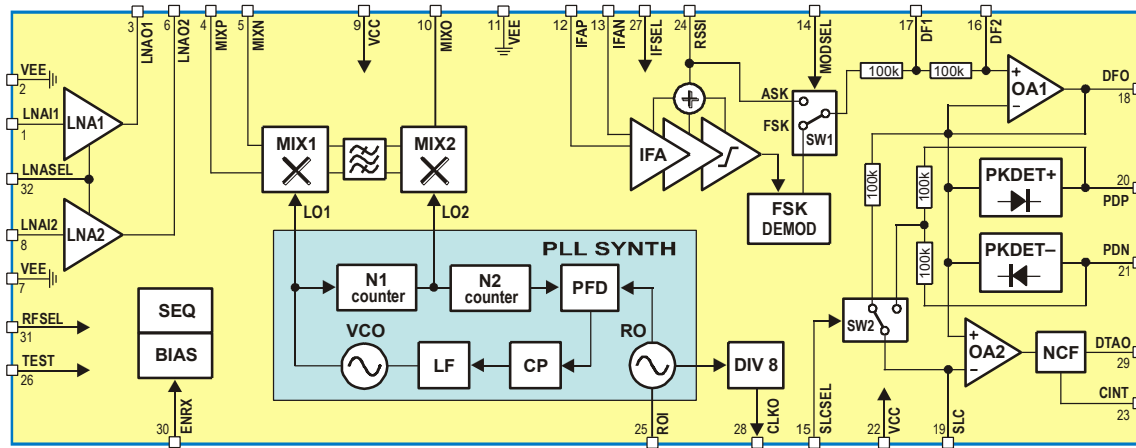

Fig. 1: MLX71120 block diagram

The MLX71120 receiver IC consists of the following building blocks:

- PLL synthesizer (PLL SYNTH) to generate the first and second local oscillator signals LO1 and LO2. The PLL SYNTH consists of a fully integrated voltage-controlled oscillator (VCO), a distributed feedback divider chain (N1, N2), a phase-frequency detector (PFD) a charge pump (CP), a loop filter (LF) and a crystal-based reference oscillator (RO).
- Two low-noise amplifiers (LNA) for high-sensitivity RF signal reception
- First mixer (MIX1) for down-conversion of the RF signal to the first IF (intermediate frequency)
- Second mixer (MIX2) with image rejection for down-conversion from the first to the second IF
- IF amplifier (IFA) to provide a high voltage gain and an RSSI signal output
- FSK demodulator (FSK DEMOD)
- Operational amplifiers OA1 and OA2 for low-pass filtering and data slicing, respectively
- Positive (PKDET+) and negative (PKDET-) peak detectors
- Switches SW1 to select between FSK and ASK as well as SW2 to chose between averaging or peak detection mode.
- Noise cancellation filter (NF)
- Sequencer circuit (SEQ) and biasing (BIAS) circuit
- Clock output (DIV8)

1.4 Operating Modes

ENRX	Description
0	Shutdown mode
1	Receive mode

Note: ENRX is pulled down internally.

1.5 Frequency Range

Two different receive frequency ranges can be selected by the control signal RFSEL.

RFSEL	Description
0	Input frequency range 300 to 470MHz
1	Input frequency range 610 to 930MHz

1.6 LNA Selection

LNA SEL	Description
0	LNA1 active, LNA2 shutdown
Hi-Z	LNA1 and LNA2 active
1	LNA1 shutdown, LNA2 active

Note: Hi-Z state means pin LNA SEL is left floating (pin is internally pulled to $V_{CC}/2$ in this case).

1.7 External IF2 Selection

IFSEL	Description
0	IF2 = 455 kHz
1	IF2 = 10.7 MHz

1.8 Demodulation Selection

MODSEL	Description
0	ASK demodulation
1	FSK demodulation

1.9 Data Slicer

SLCSEL	Description
0	Averaging detection mode
1	Peak detection mode

2 Frequency Planning

Because of the double conversion architecture that employs two mixers and two IF signals, there are four different combinations for injecting the LO1 and LO2 signals:

- LO1 high side and LO2 high side: receiving at $f_{RF}(\text{high-high})$
- LO1 high side and LO2 low side: receiving at $f_{RF}(\text{high-low})$
- LO1 low side and LO2 high side: receiving at $f_{RF}(\text{low-high})$
- LO1 low side and LO2 low side: receiving at $f_{RF}(\text{low-low})$

As a result, four different radio frequencies (RFs) could yield one and the same second IF (IF2). Fig. 2 shows this for the case of receiving at $f_{RF}(\text{high-high})$. In the example of Fig. 2, the image signals at $f_{RF}(\text{low-high})$ and $f_{RF}(\text{low-low})$ are suppressed by the bandpass characteristic provided by the RF front-end. The bandpass shape can be achieved either with a SAW filter (featuring just a couple of MHz bandwidth), or by the tank circuits at the LNA input and output (this typically yields 30 to 60MHz bandwidth). In any case, the high value of the first IF (IF1) helps to suppress the image signals at $f_{RF}(\text{low-high})$ and $f_{RF}(\text{low-low})$.

The two remaining signals at IF1 resulting from $f_{RF}(\text{high-high})$ and $f_{RF}(\text{high-low})$ are entering the second mixer MIX2. This mixer features image rejection with so-called single-sideband (SSB) selection. This means either the upper or lower sideband of IF1 can be selected. In the example of Fig. 2, LO2 high-side injection has been chosen to select the IF2 signal resulting from $f_{RF}(\text{high-high})$.

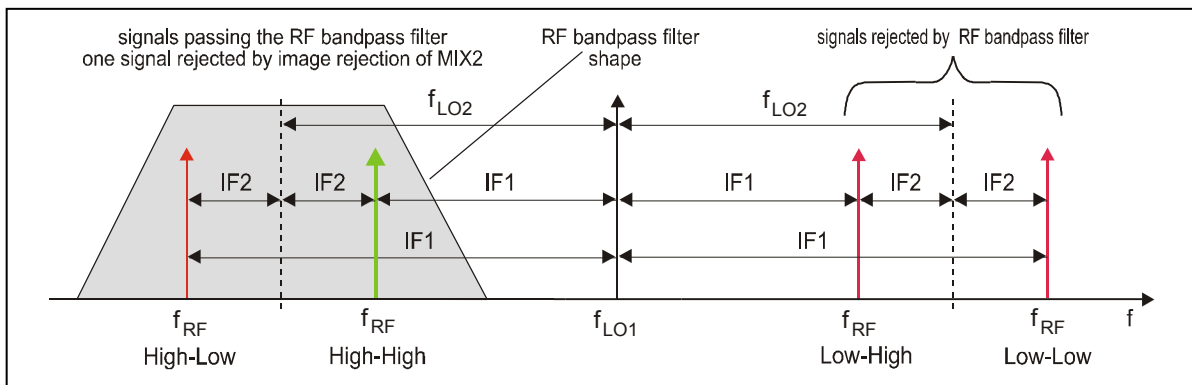

Fig. 2: The four receiving frequencies in a double conversion superhet receiver

It can be seen from the block diagram of Fig. 1 that there is a fixed relationship between the LO signal frequencies (f_{LO1} , f_{LO2}) and the reference oscillator frequency f_{RO} .

$$f_{LO1} = N_1 \cdot f_{LO2} \qquad f_{LO2} = N_2 \cdot f_{RO}$$

The IF2 frequency can be selected to 455kHz or 10.7MHz via the logic level at the IFSEL control pin. At the same time the output impedance of the 2nd mixer at pin MIXO is set according to the IF2 (please refer to pin description for details). Of course, also the operating frequency of the FSK demodulator (FSK DEMOD) is set accordingly.

2.1 Calculation of Frequency Settings

The receiver has two predefined receive frequency plans which can be selected by the RFSEL control pin. Depending on the logic level of RFSEL pin the sideband selection of the second mixer and the counter settings for N1 and N2 are changed accordingly. (see in 1.5)

RFSEL	Injection	f_{RFmin} [MHz]	f_{RFmax} [MHz]	N_1	N_2
0	high-low	300	470	4	6
1	low-high	610	930	2	12

The following table shows the relationships of several internal receiver frequencies for the two input frequency ranges.

f_{RF} [MHz]	f_{IF1}	f_{LO1}	f_{LO2}	f_{RO}
300 to 470	$\frac{f_{RF} + N_1 f_{IF2}}{N_1 - 1}$	$\frac{N_1 (f_{RF} + f_{IF2})}{N_1 - 1}$	$\frac{f_{RF} + f_{IF2}}{N_1 - 1}$	$\frac{f_{RF} + f_{IF2}}{N_2 (N_1 - 1)}$
610 to 930	$\frac{f_{RF} - N_1 f_{IF2}}{N_1 + 1}$	$\frac{N_1 (f_{RF} + f_{IF2})}{N_1 + 1}$	$\frac{f_{RF} + f_{IF2}}{N_1 + 1}$	$\frac{f_{RF} + f_{IF2}}{N_2 (N_1 + 1)}$

Given IF2 is selectable at either 455kHz or 10.7MHz and the corresponding N_1 , N_2 counter settings, above equations can be transferred into the following table.

IF2=455kHz

f_{RF} [MHz]	f_{IF1}	f_{LO1}	f_{LO2}	f_{RO}
300 to 470	$\frac{f_{RF} + 1.82MHz}{3}$	$\frac{4(f_{RF} + 0.455MHz)}{3}$	$\frac{f_{RF} + 0.455MHz}{3}$	$\frac{f_{RF} + 0.455MHz}{18}$
610 to 930	$\frac{f_{RF} - 0.91MHz}{3}$	$\frac{2(f_{RF} + 0.455MHz)}{3}$		$\frac{f_{RF} + 0.455MHz}{36}$

IF2=10.7MHz

f_{RF} [MHz]	f_{IF1}	f_{LO1}	f_{LO2}	f_{RO}
300 to 470	$\frac{f_{RF} + 42.8MHz}{3}$	$\frac{4(f_{RF} + 10.7MHz)}{3}$	$\frac{f_{RF} + 10.7MHz}{3}$	$\frac{f_{RF} + 10.7MHz}{18}$
610 to 930	$\frac{f_{RF} - 21.4MHz}{3}$	$\frac{2(f_{RF} + 10.7MHz)}{3}$		$\frac{f_{RF} + 10.7MHz}{36}$

2.2 Standard Frequency Plans

IF2 = 455kHz

f_{RF} [MHz]	f_{IF1} [MHz]	f_{LO1} [MHz]	f_{LO2} [MHz]	f_{RO} [MHz]
315	105.6067	420.6067	105.1517	17.525277
433.92	145.2467	579.1667	144.7917	24.131944
868.3	289.1300	579.1700	289.5850	24.132083
915	304.6967	610.3033	305.1517	25.429305

IF2 = 10.7MHz

f_{RF} [MHz]	f_{IF1} [MHz]	f_{LO1} [MHz]	f_{LO2} [MHz]	f_{RO} [MHz]
315	119.2667	434.2667	108.5667	18.094444
433.92	158.0667	592.8267	148.2067	24.701111
868.3	282.3000	586.0000	293.0000	24.416666
915	297.8667	617.1333	308.5667	25.713888

2.3 433/868MHz Frequency Diversity

The receiver's multi-band functionality can be used to operate at two different frequency bands just by changing the logic level at pin RFSEL and without changing the crystal. This feature is applicable for common use of the 433 and 868MHz bands. Below table shows the corresponding frequency plans.

IF2 = 455kHz

RFSEL	f_{RF} [MHz]	f_{IF1} [MHz]	f_{LO1} [MHz]	f_{LO2} [MHz]	f_{RO} [MHz]
0	433.9225	145.2483	579.17	144.7925	24.132083
1	868.3	289.1300	579.17	289.5850	

3 Dual-Channel Application Circuits for FSK & ASK Reception

3.1 Peak Detector Data Slicer

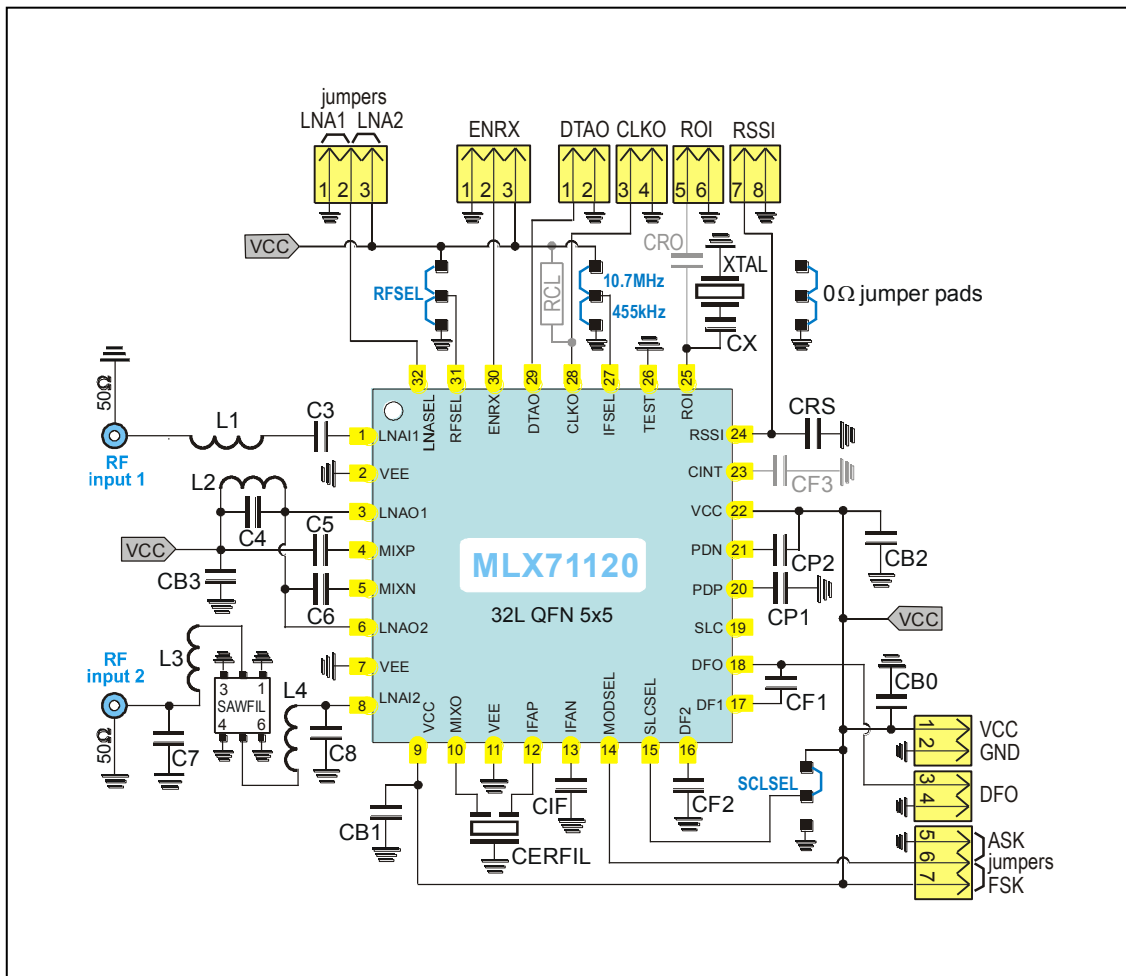

Fig. 3: Circuit schematic

3.1.1 Component Arrangement Top Side (Peak Detection Data Slicer, IF2 = 10.7MHz)

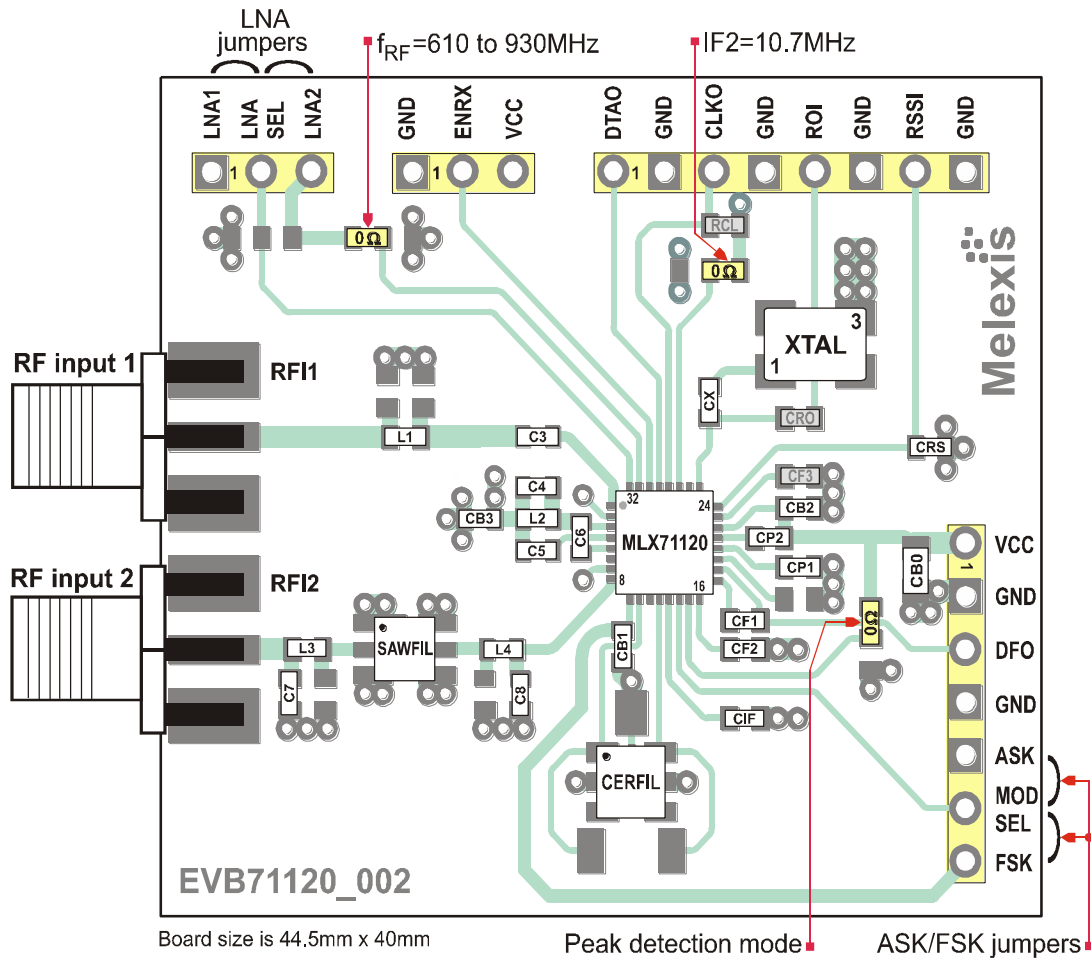

Fig. 4: PCB top-side view

3.1.2 Component Arrangement Top Side (Peak Detection Data Slicer, IF2 = 455kHz)

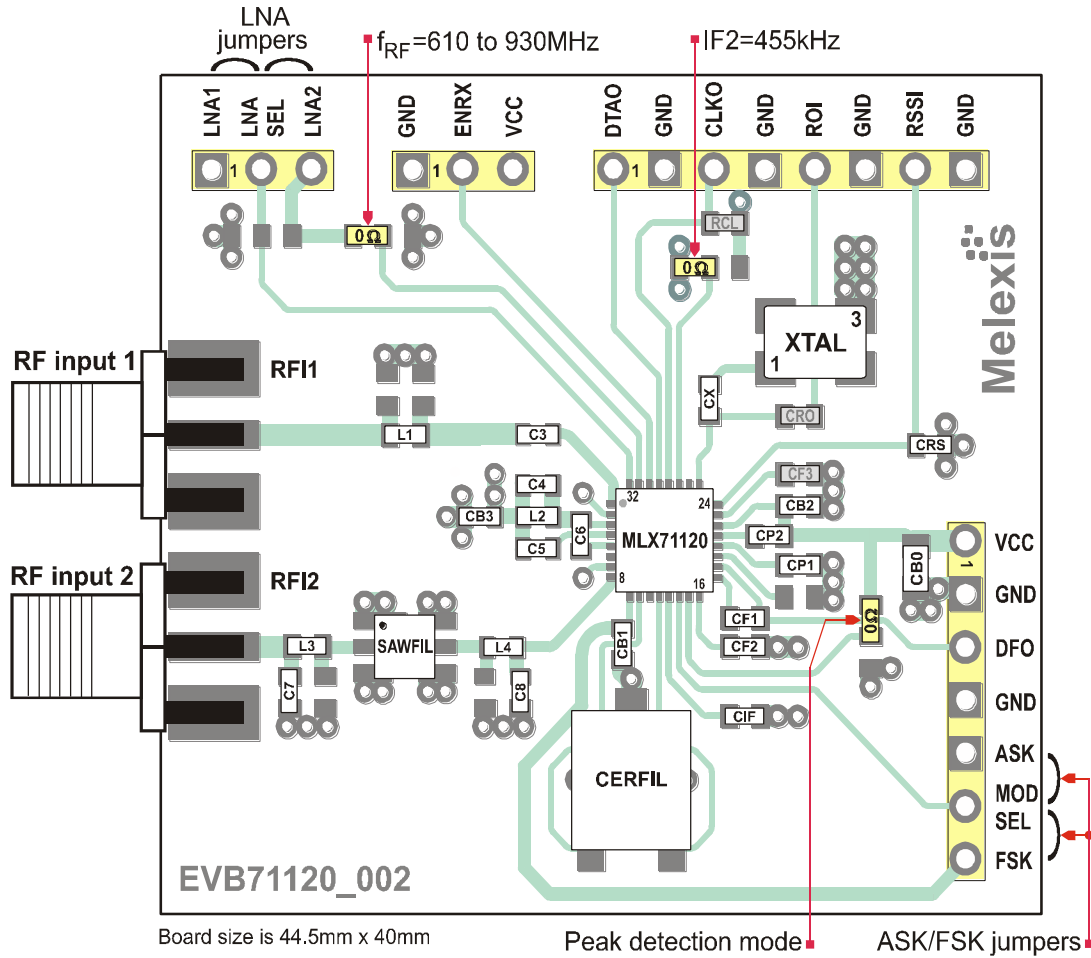

Fig. 5: PCB top-side view

3.2 Averaging Data Slicer Configured for Bi-Phase Codes

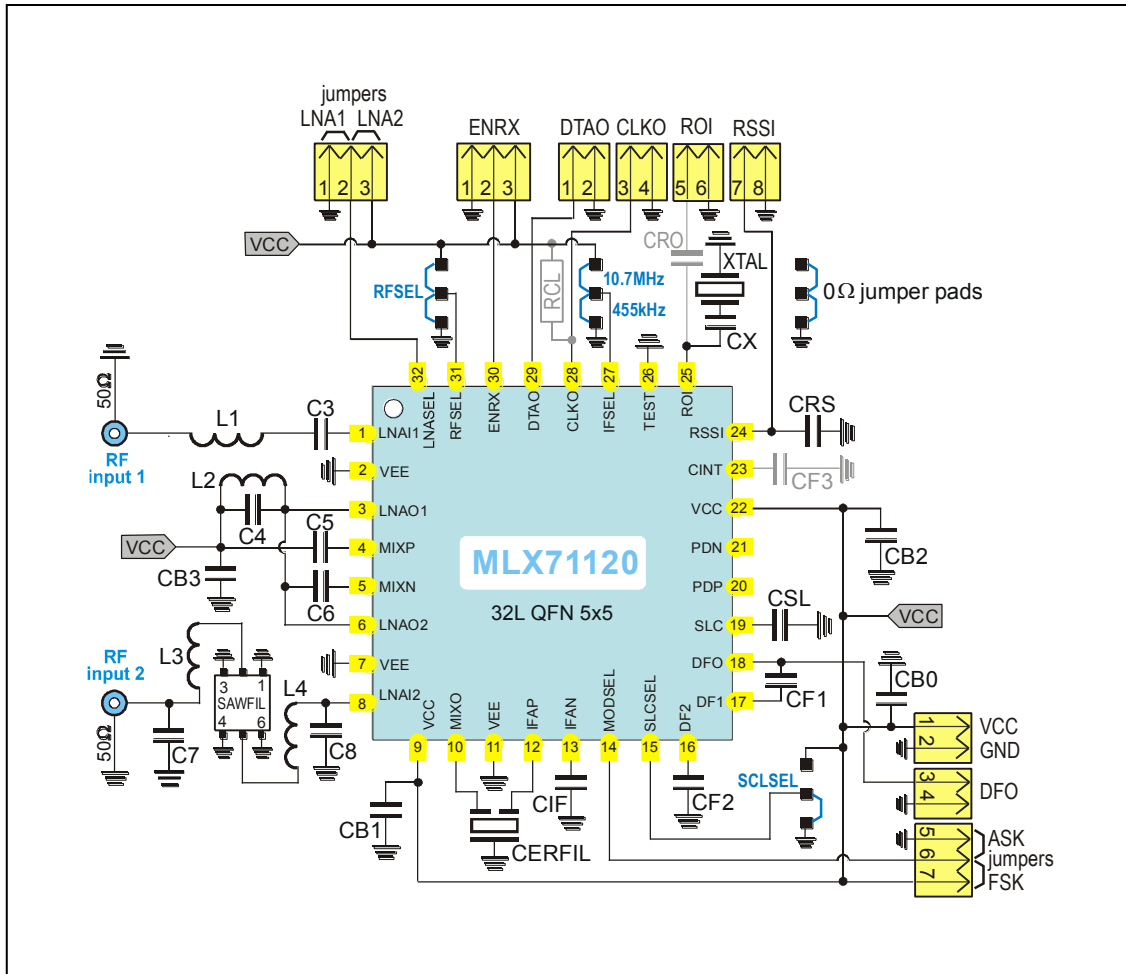

Fig. 6: Circuit schematic

3.2.1 Component Arrangement Top Side (Averaging Data Slicer, IF2 = 10.7MHz)

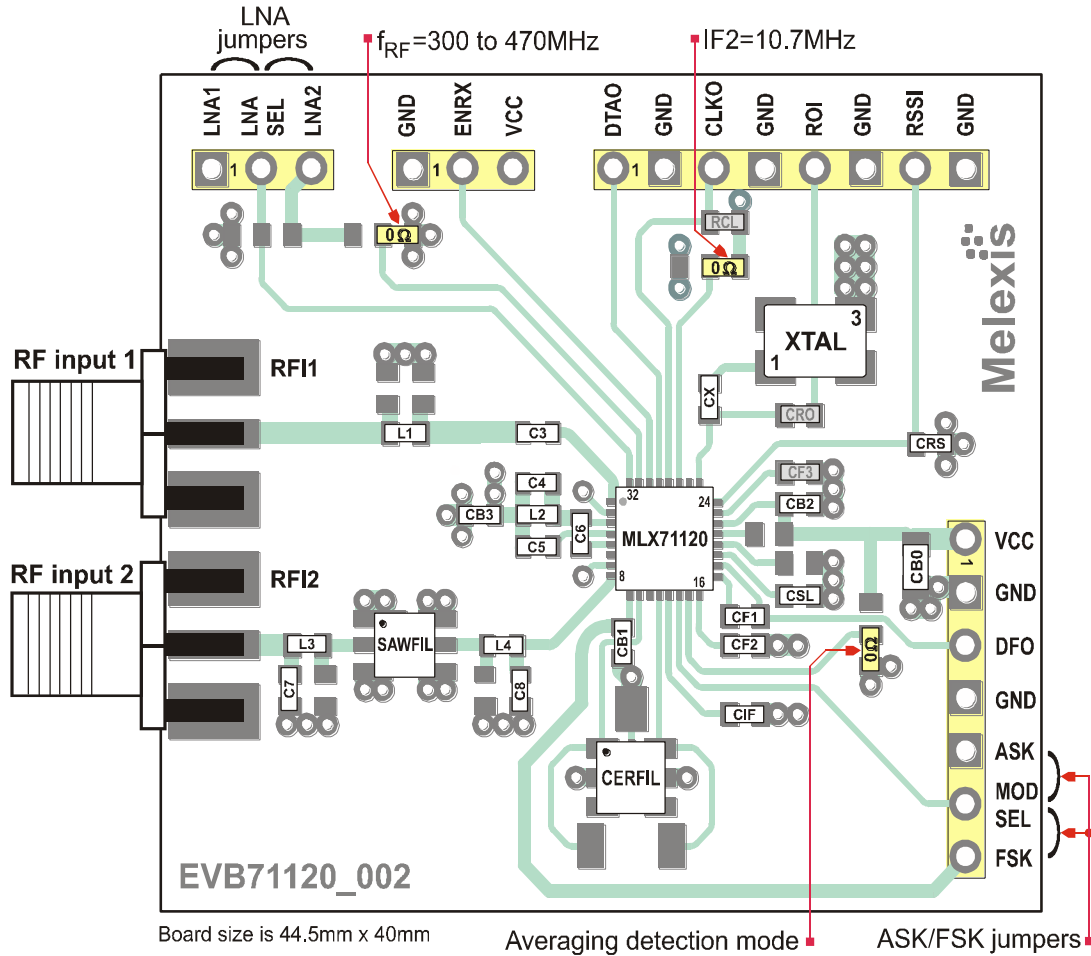

Fig. 7: PCB top-side view

3.3 Component List for Dual-Channel Application

Below table is valid for test circuits shown in Figures 3.1 to 3.2.

Part	Size	Value @ 315 MHz	Value @ 433.92 MHz	Value @ 868.3 MHz	Value @ 915 MHz	Tol.	Description	
C3	0603	100 pF	100 pF	100 pF	100 pF	±5%	LNA input filtering capacitor	
C4	0603	4.7 pF	3.9 pF	2.2 pF	1.5 pF	±5%	LNA output tank capacitor	
C5	0603	100 pF	100 pF	100 pF	100 pF	±5%	MIX1 positive input matching capacitor	
C6	0603	100 pF	100 pF	100 pF	100 pF	±5%	MIX1 negative input matching capacitor	
C7	0603	NIP	4.7 pF	3.9 pF	NIP	±5%	matching capacitor	
C8	0603	NIP	NIP	1.0 pF	NIP	±5%	matching capacitor	
CB0	0805	330 nF	330 nF	330 nF	330 nF	±10%	decoupling capacitor	
CB1	0603	330 pF	330 pF	330 pF	330 pF	±10%	decoupling capacitor	
CB2	0603	330 pF	330 pF	330 pF	330 pF	±10%	decoupling capacitor	
CB3	0603	330 pF	330 pF	330 pF	330 pF	±10%	decoupling capacitor	
CF1	0603	680 pF	680 pF	680 pF	680 pF	±10%	data low-pass filter capacitor, for data rate of 4 kbps NRZ	
CF2	0603	330 pF	330 pF	330 pF	330 pF	±10%	data low-pass filter capacitor, for data rate of 4 kbps NRZ	
CF3	0603	value according to the data rate connected to ground if noise filter not used				±10%	optional capacitor for noise cancellation filter	
CIF	0603	1 nF	1 nF	1 nF	1 nF	±10%	IFA feedback capacitor	
CP1	0603	33 nF	33 nF	33 nF	33 nF	±10%	positive PKDET capacitor, for data rate of 4 kbps NRZ	
CP2	0603	33 nF	33 nF	33 nF	33 nF	±10%	negative PKDET capacitor, for data rate of 4 kbps NRZ	
CRS	0603	1 nF	1 nF	1 nF	1 nF	±10%	RSSI output low pass capacitor	
CRO	0603	1 nF	1 nF	1 nF	1 nF	±5%	optional capacitor, to couple external RO signal	
CSL	0603	100 nF	100 nF	100 nF	100 nF	±10%	data slicer capacitor, for data rate of 4 kbps NRZ	
		for averaging detection mode only						
CX	0603	27 pF	27 pF	27 pF	27 pF	±5%	crystal series capacitor	
L1	0603	56 nH	27 nH	0 Ω	0 Ω	±5%	matching inductor	
L2	0603	27 nH	15 nH	3.9 nH	3.9 nH	±5%	LNA output tank inductor	
L3	0603	0 Ω	47 nH	22 nH	0 Ω	±5%	matching inductor	
L4	0603	56 nH	68 nH	22 nH	0 Ω	±5%	matching inductor	
RCL	0603	3.3 kΩ	3.3 kΩ	3.3 kΩ	3.3 kΩ	±5%	optional CLK output resistor, to clock output signal generated	
SAW FIL	SMD 3x3	SAFDC315M SM0T00 (315 MHz)	RF3446 (433.92 MHz)	SAFCC868M SLOX00 (868.3 MHz)	SAFCC915M AL0N00 (915 MHz)		low-loss SAW filter from Murata or equivalent part	
CER FIL	SMD 3.45x3.1	SFECF10M7HA00 B _{3dB} = 180 kHz					IF2=10.7MHz	ceramic filter from Murata, or equivalent part
	SMD 6.5x6.0	CFUKG455KD4A B _{6dB} = 20 kHz					IF2=455kHz	
XTAL	SMD 5x3.2	18.094444 MHz	24.701111 MHz	24.416667 MHz	25.713889 MHz		IF2=10.7MHz	crystal from Telcona, or equivalent part
		HEX24-18.094444M HZ-12-50-F-H20-T2075-W2-T	HEX24-24.701111MHZ -12-50-F-H20-T2075-W2-T	HEX24-24.416667MH Z-12-50-F-H20-T2075-W2-T	HEX24-25.713889M HZ-12-50-F-H20-T2075-W2-T			
		17.525278 MHz	24.132083 MHz		25.429306 MHz			
		±20ppm cal., ±30ppm temp.						

Note: NIP – not in place, may be used optionally

3.4 PCB Layouts for Antenna Space Diversity

- Board layout data in Gerber format is available, board size is 40mm x 44.5mm.

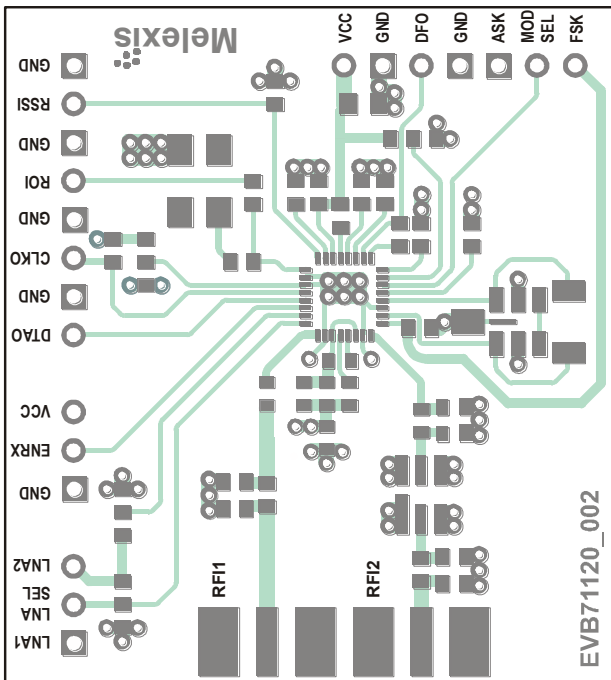

PCB top view

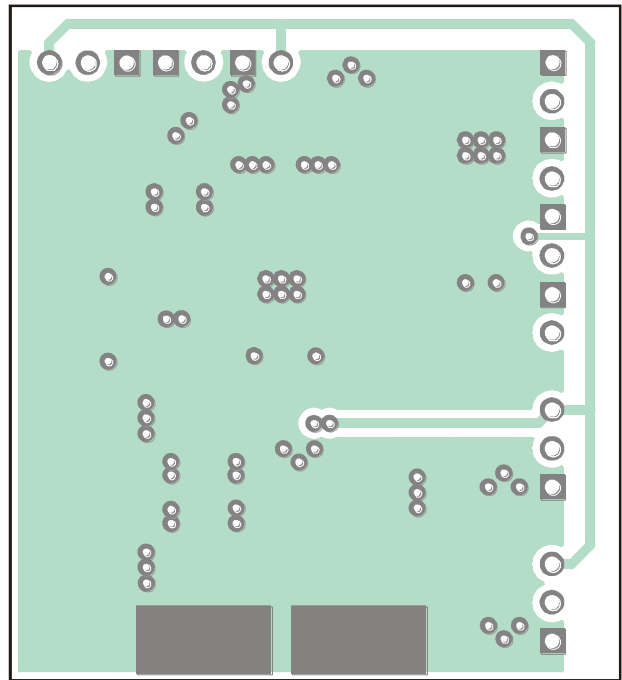

PCB bottom view

4 Board Variants

Type	Frequency/MHz	Board Execution
EVB71120	-315	-A antenna version
	-433	-C connector version
	-868	
	-915	

Note: available EVB setups

5 Package Description

 The device MLX71120 is RoHS compliant.

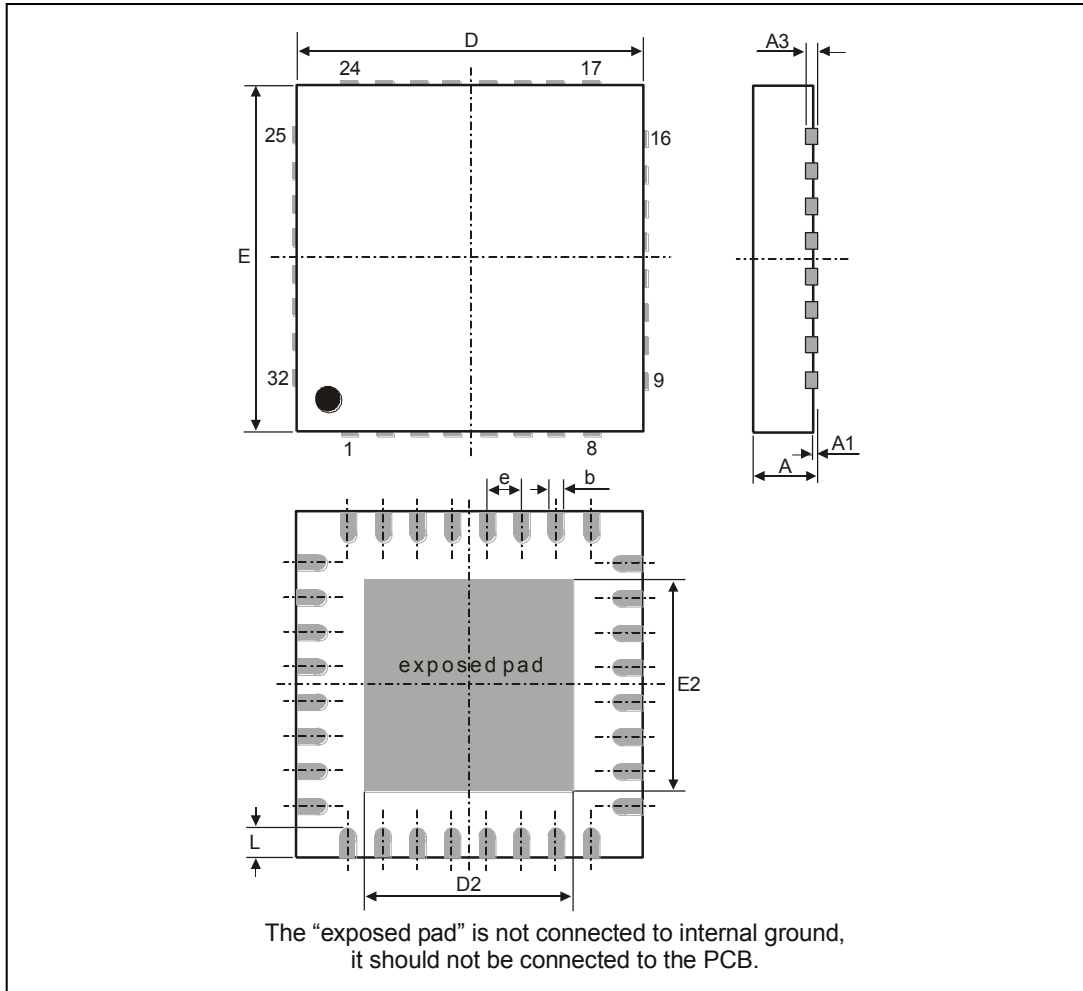

Fig. 8: 32L QFN 5x5 Quad

all Dimension in mm										
	D	E	D2	E2	A	A1	A3	L	e	b
min	4.75	4.75	3.00	3.00	0.80	0	0.20	0.3	0.50	0.18
max	5.25	5.25	3.25	3.25	1.00	0.05	0.20	0.5	0.50	0.30
all Dimension in inch										
min	0.187	0.187	0.118	0.118	0.0315	0	0.0079	0.0118	0.0197	0.0071
max	0.207	0.207	0.128	0.128	0.0393	0.002	0.0079	0.0197	0.0197	0.0118

5.1 Soldering Information

- The device MLX71120 is qualified for MSL3 with soldering peak temperature 260 deg C according to JEDEC J-STD-20

6 Reliability Information

This Melexis device is classified and qualified regarding soldering technology, solderability and moisture sensitivity level, as defined in this specification, according to following test methods:

Reflow Soldering SMD's (Surface Mount Device)s

- IPC/JEDEC J-STD-020
"Moisture/Reflow Sensitivity Classification for Nonhermetic Solid State Surface Mount Devices (classification reflow profiles according to table 5-2)"
- EIA/JEDEC JESD22-A113
"Preconditioning of Nonhermetic Surface Mount Devices Prior to Reliability Testing (reflow profiles according to table 2)"

Wave Soldering SMD's (Surface Mount Device)s and THD's (Through Hole Device)s

- EN60749-20
"Resistance of plastic- encapsulated SMD's to combined effect of moisture and soldering heat"
- EIA/JEDEC JESD22-B106 and EN60749-15
"Resistance to soldering temperature for through-hole mounted devices"

Iron Soldering THD's (Through Hole Device)s

- EN60749-15
"Resistance to soldering temperature for through-hole mounted devices"

Solderability SMD's (Surface Mount Device)s and THD's (Through Hole Device)s

- EIA/JEDEC JESD22-B102 and EN60749-21
"Solderability"

For all soldering technologies deviating from above mentioned standard conditions (regarding peak temperature, temperature gradient, temperature profile etc) additional classification and qualification tests have to be agreed upon with Melexis.

The application of Wave Soldering for SMD's is allowed only after consulting Melexis regarding assurance of adhesive strength between device and board.

Melexis is contributing to global environmental conservation by promoting **lead free** solutions. For more information on qualification of **RoHS** compliant products (RoHS = European directive on the Restriction Of the Use of Certain Hazardous Substances) please visit the quality page on our website:

http://www.melexis.com/quality_leadfree.aspx

7 ESD Precautions

Electronic semiconductor products are sensitive to Electro Static Discharge (ESD). Always observe Electro Static Discharge control procedures whenever handling semiconductor products.

8 Disclaimer

- 1) The information included in this documentation is subject to Melexis intellectual and other property rights. Reproduction of information is permissible only if the information will not be altered and is accompanied by all associated conditions, limitations and notices.
 - 2) Any use of the documentation without the prior written consent of Melexis other than the one set forth in clause 1 is an unfair and deceptive business practice. Melexis is not responsible or liable for such altered documentation.
 - 3) The information furnished by Melexis in this documentation is provided 'as is'. Except as expressly warranted in any other applicable license agreement, Melexis disclaims all warranties either express, implied, statutory or otherwise including but not limited to the merchantability, fitness for a particular purpose, title and non-infringement with regard to the content of this documentation.
 - 4) Notwithstanding the fact that Melexis endeavors to take care of the concept and content of this documentation, it may include technical or factual inaccuracies or typographical errors. Melexis disclaims any responsibility in connection herewith.
 - 5) Melexis reserves the right to change the documentation, the specifications and prices at any time and without notice. Therefore, prior to designing this product into a system, it is necessary to check with Melexis for current information.
 - 6) Melexis shall not be liable to recipient or any third party for any damages, including but not limited to personal injury, property damage, loss of profits, loss of use, interrupt of business or indirect, special incidental or consequential damages, of any kind, in connection with or arising out of the furnishing, performance or use of the information in this documentation.
 - 7) The product described in this documentation is intended for use in normal commercial applications. Applications requiring operation beyond ranges specified in this documentation, unusual environmental requirements, or high reliability applications, such as military, medical life-support or life-sustaining equipment are specifically not recommended without additional processing by Melexis for each application.
 - 8) Any supply of products by Melexis will be governed by the Melexis Terms of Sale, published on www.melexis.com.
- © Melexis NV. All rights reserved.

For the latest version of this document, go to our website at:

www.melexis.com

Or for additional information contact Melexis Direct:

Europe, Africa:
Phone: +32 1367 0495
E-mail: sales_europe@melexis.com

Americas:
Phone: +1 603 223 2362
E-mail: sales_usa@melexis.com

Asia:
Phone: +32 1367 0495
E-mail: sales_asia@melexis.com

ISO/TS 16949 and ISO14001 Certified

Mouser Electronics

Authorized Distributor

Click to View Pricing, Inventory, Delivery & Lifecycle Information:

[Melexis:](#)

[EVB71120-868-C](#) [EVB71120-433-C](#) [EVB71120-915-C](#) [EVB71120-315-C](#)