

NOTES:

MATERIAL: PHOSPHOR BRONZE
 PLATING: 10u" GOLD OVER 50u" NICKEL
 NICKEL ON WIRE CRIMP AREA
 WIRE SIZE: 24-26 AWG
 CONTACT RESISTANCE: 20 mOHMS INITIAL
 CONTACT AMPERAGE RATING: 3 AMPS

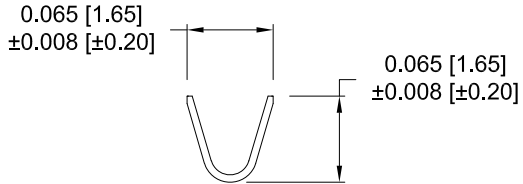

SECTION A - A

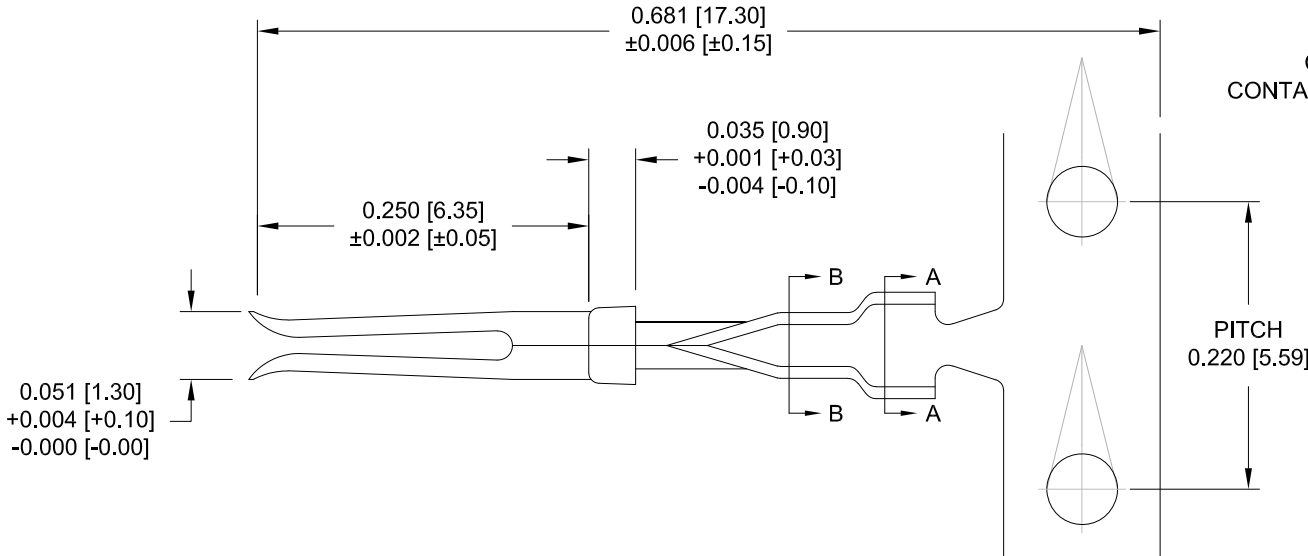
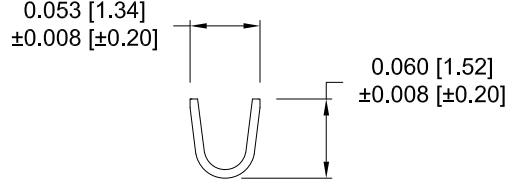
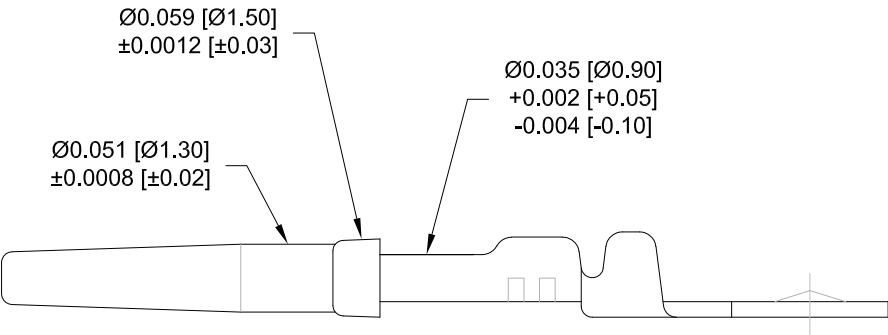

SECTION B - B

180-Y02-170L001

FOR CLARITY
 HIDDEN LINES
 NOT SHOWN

SERIES _____
 TYPE _____
 0 = REEL (10,000 per reel)
 1 = LOOSE (500 per bag)
 GENDER _____
 1 = FEMALE

RoHS COMPLIANT

UNITS = inch [mm] DO NOT SCALE FROM DRAWING

 THESE DRAWINGS AND SPECIFICATIONS ARE THE PROPERTY OF NorComp AND SHALL NOT BE REPRODUCED, COPIED OR USED AS THE BASIS FOR THE MANUFACTURE OR SALE OF APPARATUS WITHOUT WRITTEN PERMISSION.

DRAWN: J. KADEL
 DATE: 09/03/2019

NorComp

SCALE: NTS	SHEET 1	OF 2	REV 1
DWG NO.		180-Y02-170L001	

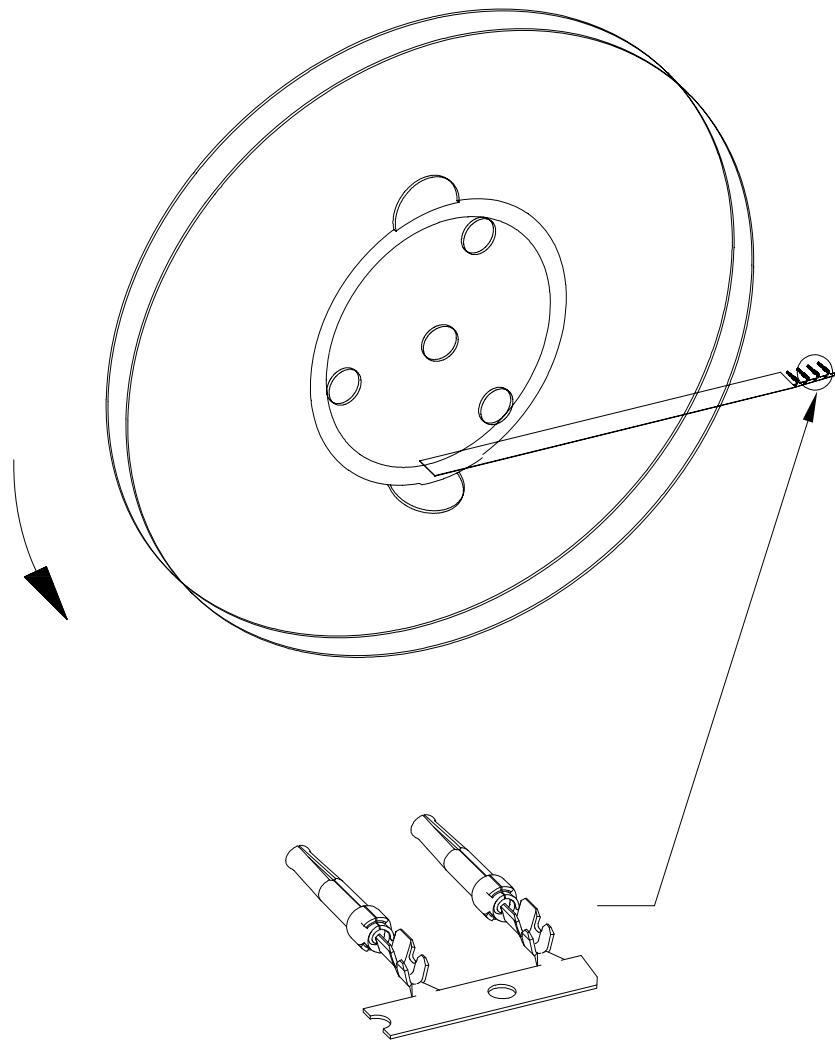

RoHS COMPLIANT

DO NOT SCALE FROM DRAWING



THESE DRAWINGS AND SPECIFICATIONS ARE THE PROPERTY OF NorComp AND SHALL NOT BE REPRODUCED, COPIED OR USED AS THE BASIS FOR THE MANUFACTURE OR SALE OF APPARATUS WITHOUT WRITTEN PERMISSION.

DRAWN:
J. KADEL
DATE:
09/03/2019

NorComp

SCALE: NTS	SHEET 2	OF 2	REV 1
DWG NO.		180-Y02-170L001	

Mouser Electronics

Authorized Distributor

Click to View Pricing, Inventory, Delivery & Lifecycle Information:

[NorComp:](#)

[180-102-170L001](#)