

SECTION A-A

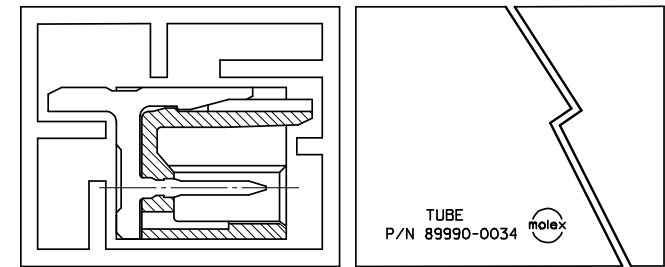

PART LOADING INTO TUBE DIRECTION

NOTES:

1. MATERIALS:  
HOUSING: NYLON, GLASS-FILLED, UL94 V-0;  
COLOR: SEE TABLE  
PINS: BRASS ALLOY, C26000
2. PLATING: 2.54MM MIN. TIN OVER 1.27MM MIN. NICKEL.
3. DRAWING SHOWS PLUG WITH 5 CIRCUITS.
4. HEADER TO BE USED WITH CRIMP HOUSING, P/N 87439 AND CRIMP TERMINAL, P/N 87421
5. PARTS SHALL BE PACKED IN MOISTURE BARRIER BAG.

ADD TUBE DETAILS EC NO: S2008-0476 DRWN:SKANG 2007/12/14 CHYKD:ATSEE 2007/12/18 APPR:MLONG 2007/12/18	QUALITY SYMBOLS ▽=0 ∇=0	GENERAL TOLERANCES (UNLESS SPECIFIED)		DIMENSION STYLE MM ONLY		SCALE NTS	DESIGN UNITS METRIC	THIRD ANGLE PROJECTION		
			mm	INCH	DRAWN BY KCL ING	DATE 1994/04/08	TITLE 1.50MM PITCH, W-T-B HEADER, R/A, SMT			
		4 PLACES	± ---	± ---	CHECKED BY SKTOH	DATE 1994/04/21	MOLEX INCORPORATED SD-87438-**-31			
		3 PLACES	± ---	± ---	APPROVED BY RWONG	DATE 1994/04/24				
2 PLACES	± 0.20	± ---	MATERIAL NO. SEE TABLE		DOCUMENT NO. SD-87438-**-31		SHEET NO. 1 OF 3			
1 PLACE	± ---	± ---	DRAFT WHERE APPLICABLE MUST REMAIN WITHIN DIMENSIONS THIS DRAWING CONTAINS INFORMATION THAT IS PROPRIETARY TO MOLEX INCORPORATED AND SHOULD NOT BE USED WITHOUT WRITTEN PERMISSION							

10 9 8 7 6 5 4 3 2 1

CKT SIZE	DESIGN UNITS				
	A	B	C	D	E
02	1.50	3.30	3.70	4.30	1.70
03	3.00	4.80	5.20	5.80	3.20
04	4.50	6.30	6.70	7.30	4.70
05	6.00	7.80	8.20	8.80	6.20
06	7.50	9.30	9.70	10.30	7.70
07	9.00	10.80	11.20	11.80	9.20
08	10.50	12.30	12.70	13.30	10.70
09	12.00	13.80	14.20	14.80	12.20
10	13.50	15.30	15.70	16.30	13.70
11	15.00	16.80	17.20	17.80	15.20
12	16.50	18.30	18.70	19.30	16.70
13	18.00	19.80	20.20	20.80	18.20
14	19.50	21.30	21.70	22.30	19.70
15	21.00	22.80	23.20	23.80	21.20

PART NUMBER ASSIGNMENT

87438-XXXX

- 2- TUBE PACKAGING
- 3- TAPE AND REEL PACKAGING
- 4- BEIGE COLOR HSG
- 6- BLACK COLOR HSG
- 2 TO 15 - CIRCUIT SIZE

ADD TUBE DETAILS EC NO: S2008-0476 DRWN:SKANG CHKD:ATSEE APPR:MLONG	2007/12/14 2007/12/18 2007/12/18	DESCRIPTION REV	QUALITY SYMBOLS	GENERAL TOLERANCES (UNLESS SPECIFIED) mm INCH 4 PLACES ± --- ± --- 3 PLACES ± --- ± --- 2 PLACES ± 0.20 ± --- 1 PLACE ± --- ± --- ANGULAR ± 3 °	DIMENSION STYLE	SCALE	DESIGN UNITS	THIRD ANGLE PROJECTION		
			▽=0 ◻=0		MM ONLY	NTS	METRIC	DRAWN BY DATE KCL ING 1994/04/08 CHECKED BY DATE SKTOH 1994/04/21 APPROVED BY DATE RWONG 1994/04/24	TITLE	1.50MM PITCH, W-T-B HEADER, R/A, SMT
					SEE TABLE	MOLEX INCORPORATED DOCUMENT NO. SD-87438-**31	SHEET NO.	2 OF 3		
			DRAFT WHERE APPLICABLE MUST REMAIN WITHIN DIMENSIONS		THIS DRAWING CONTAINS INFORMATION THAT IS PROPRIETARY TO MOLEX INCORPORATED AND SHOULD NOT BE USED WITHOUT WRITTEN PERMISSION					

9 8 7 6 5 4 3 2 1

10	9	8	7	6	5	4	3	2	1
15	44	20.20	100	44.40	50.40				
11, 12, 13, 14	32	14.20	100	32.40	38.40				
7, 8, 9, 10	24	11.50	100	24.40	30.40				
2, 3, 4, 5, 6	16	7.50	100	16.40	22.40				
CIRCUIT SIZE	A	B	N	G	T MAX				

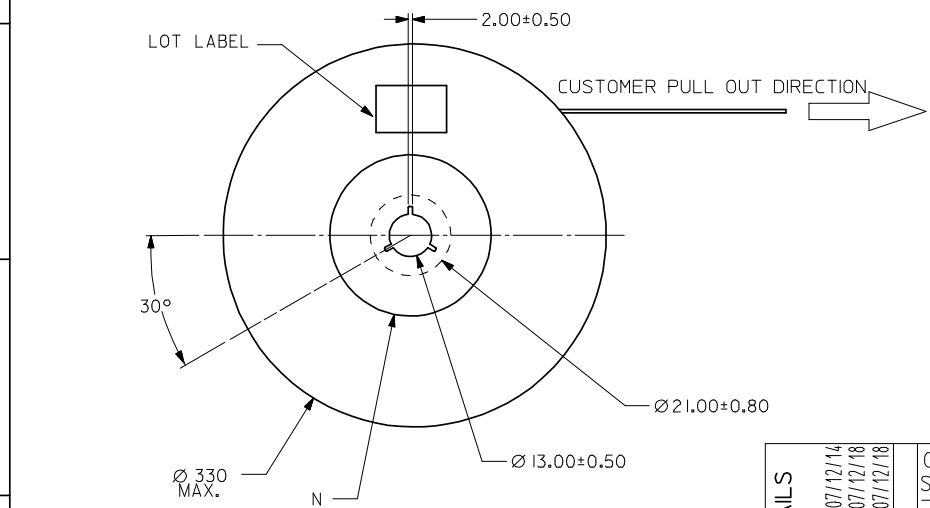
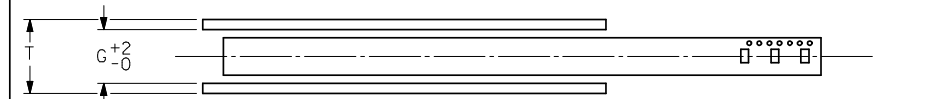
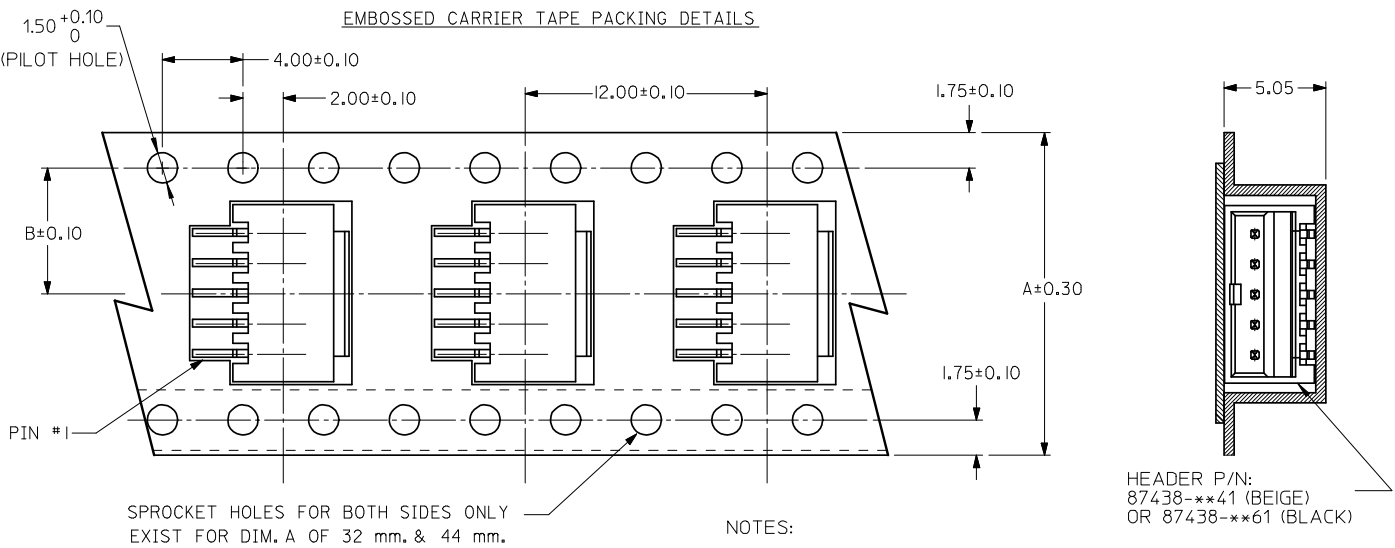

- NOTES:
- LEADER AND TRAILER TAPE
  - PEELING OFF FORCE OF THE TOP TAPE: 20-80gf.  
 (PEELING DIRECTION AS SHOWN IN FOLLOWING FIGURE)
  - PACKAGING STANDARD IS AS PER EIA-481.
  - TAPE & REEL QUANTITY = 1000PCS/REEL
  - THE TAPE IS TREATED FOR ANTI-STATIC

ADD TUBE DETAILS EC NO: S2008-0476 DRWN:SKANG CHKD:ATSEE APPR:MLONG 2007/12/14 2007/12/18 2007/12/18	QUALITY SYMBOLS	GENERAL TOLERANCES (UNLESS SPECIFIED)	DIMENSION STYLE	SCALE	DESIGN UNITS	THIRD ANGLE PROJECTION																				
	$\nabla=0$ $\nabla=0$	<table border="1"> <tr> <td></td> <td>mm</td> <td>INCH</td> </tr> <tr> <td>4 PLACES</td> <td>± ---</td> <td>± ---</td> </tr> <tr> <td>3 PLACES</td> <td>± ---</td> <td>± ---</td> </tr> <tr> <td>2 PLACES</td> <td>± 0.20</td> <td>± ---</td> </tr> <tr> <td>1 PLACE</td> <td>± ---</td> <td>± ---</td> </tr> </table>		mm	INCH	4 PLACES	± ---	± ---	3 PLACES	± ---	± ---	2 PLACES	± 0.20	± ---	1 PLACE	± ---	± ---	MM ONLY	NTS	METRIC						
		mm	INCH																							
	4 PLACES	± ---	± ---																							
3 PLACES	± ---	± ---																								
2 PLACES	± 0.20	± ---																								
1 PLACE	± ---	± ---																								
DRAFT WHERE APPLICABLE MUST REMAIN WITHIN DIMENSIONS	<table border="1"> <tr> <td>DRAWN BY</td> <td>DATE</td> <td>TITLE</td> </tr> <tr> <td>KCLING</td> <td>1994/04/08</td> <td>150MM PITCH, W-T-B HEADER, R/A, SMT</td> </tr> <tr> <td>CHECKED BY</td> <td>DATE</td> <td></td> </tr> <tr> <td>SKTOH</td> <td>1994/04/21</td> <td></td> </tr> <tr> <td>APPROVED BY</td> <td>DATE</td> <td></td> </tr> <tr> <td>RWONG</td> <td>1994/04/24</td> <td></td> </tr> </table>	DRAWN BY	DATE	TITLE	KCLING	1994/04/08	150MM PITCH, W-T-B HEADER, R/A, SMT	CHECKED BY	DATE		SKTOH	1994/04/21		APPROVED BY	DATE		RWONG	1994/04/24		<table border="1"> <tr> <td>MATERIAL NO.</td> <td>DOCUMENT NO.</td> <td>SHEET NO.</td> </tr> <tr> <td>SEE TABLE</td> <td>SD-87438-***31</td> <td>3 OF 3</td> </tr> </table>	MATERIAL NO.	DOCUMENT NO.	SHEET NO.	SEE TABLE	SD-87438-***31	3 OF 3
DRAWN BY	DATE	TITLE																								
KCLING	1994/04/08	150MM PITCH, W-T-B HEADER, R/A, SMT																								
CHECKED BY	DATE																									
SKTOH	1994/04/21																									
APPROVED BY	DATE																									
RWONG	1994/04/24																									
MATERIAL NO.	DOCUMENT NO.	SHEET NO.																								
SEE TABLE	SD-87438-***31	3 OF 3																								
THIS DRAWING CONTAINS INFORMATION THAT IS PROPRIETARY TO MOLEX INCORPORATED AND SHOULD NOT BE USED WITHOUT WRITTEN PERMISSION																										