

REVISIONS					
P	LTR	DESCRIPTION	DATE	DWN	APVD
	N2	REVISED PER ECO-12-007718	07MAY12	KH	DR
	N3	REVISED PER ECO-17-007400	28NOV2017	RS	DR

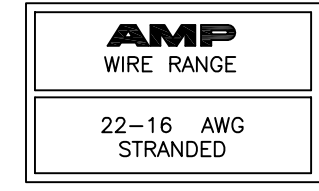
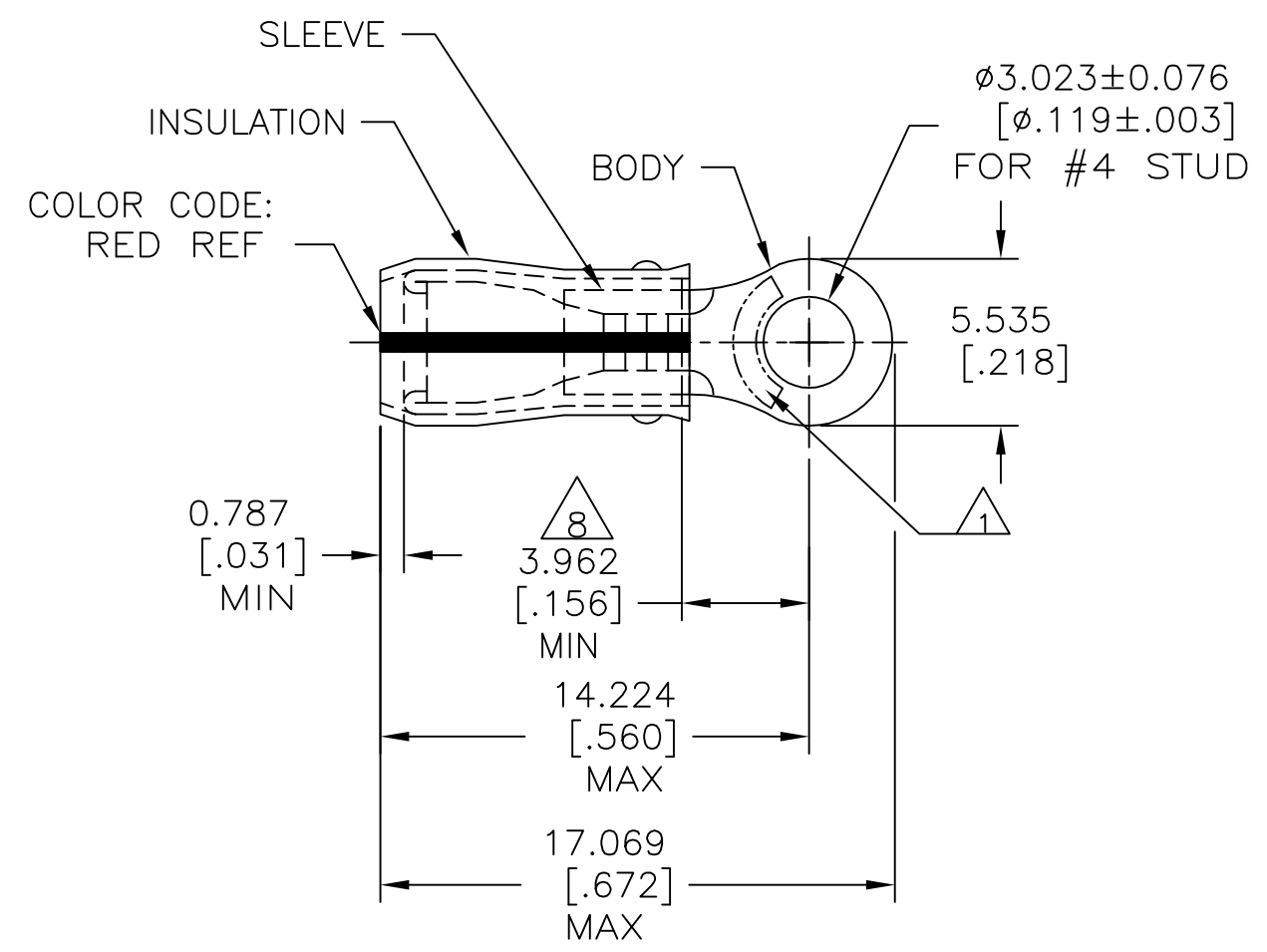

- 1 STAMP AMP 22-18* APPROX AS SHOWN
22-16 TERMINALS ARE STAMPED 22-18 IN ACCORDANCE WITH MILITARY SPEC SAE AS7928 COMMERCIAL WIRE RANGE IS 22-16.
- 2 WIRE INSULATION: $\phi 2.032-3.175[\phi .080-.125]$
- 3 BODY MATERIAL THK: $0.787\pm 0.051[.031\pm .002]$
- 4 TIN/LEAD (93-7) PLATE PER ASTM B545. (3% MIN LEAD CONTENT).
- 5 NOTE DELETED.
- 6 NOTE DELETED.
- 7 MATERIAL: BODY & SLEEVE- CU PER ASTM B152 INSULATION - PVF2, COLOR - NATURAL
- 8 DIMENSION APPLIES FROM EDGE OF METAL WIRE BARREL TO CENTER OF STUD HOLE.

M7928/4-148, CLASS 1 & 2 M7928/13-148, CLASS 1 & 2	1000	LOOSE PIECE	53405-1
MILITARY P/N & CLASS	QTY	PACKAGE TYPE	PART NO.

AMP INCORPORATED CUSTOMER SERVICE SYSTEMS		MAX RECOMMENDED OPERATING TEMPERATURE: 150°C[302°F] MAX	THIS DRAWING IS A CONTROLLED DOCUMENT.		DWN DK SCHRUM 06/16/93	TE Connectivity NAME TERMINAL, RING TONGUE, PVF2, P.I.D.G. WIRE SIZE: 22-16 AWG				
FOR ADDITIONAL PRODUCT INFORMATION OR COPIES OF DRAWINGS AND TECHNICAL DOCUMENTS	PRODUCT INFORMATION CENTER 1-800-522-6752	VOLTAGE RATING: N/A	DIMENSIONS: mm [INCHES]	TOLERANCES UNLESS OTHERWISE SPECIFIED:	CHK RE HERSEY 7/6/93					APVD M BARNABA 7/6/93
FOR APPLICATION TOOLING INFORMATION	TOOLING ASSISTANCE CENTER 1-800-722-1111	CIRCULAR MIL AREA: 0.26-1.65mm² [509-3260] STRANDED		0 PLC ± - 1 PLC ± - 2 PLC ± - 3 PLC ± 0.127[.005] 4 PLC ± - ANGLES ± -	APPL. SPEC 114-2157	WEIGHT -	A3	00779	C=53405	-
FOR ORDER ENTRY	1-800-526-5142	THIS DRAWING IS A CONTROLLED DOCUMENT FOR AMP INCORPORATED. IT IS SUBJECT TO CHANGE AND THE CONTROLLING ENGINEERING ORGANIZATION SHOULD BE CONTACTED FOR THE LATEST REVISION.	MATERIAL 	FINISH 	CUSTOMER DRAWING	SCALE 4:1	SHEET 1 OF 1	REV N3		