

XDSL Splitter Filter Module



- Ⓜ POTS Central Office Splitter for standard ADSL applications
- Ⓜ Complies with option A of ETSI specification TS 101-952-1-1
- Ⓜ Part of a standard series which has footprint compaibility
- Ⓜ ADLS2+ compatible
- Ⓜ Low profile version of B8049: 12.5 mm height
- Ⓜ NL version: RoHS-6 compliant

Electrical Specifications @ 25°C		
PARAMETER	FREQUENCY	
POTS Impedance	100Hz to 4kHz	270Ω + 750Ω / 150nF
POTS Insertion Loss	1Hz	-1.0dB MAX
POTS Insertion Loss Distortion relative to 1 kHz	200Hz to 4kHz	-1.0dB MAX
POTS Return Loss	300Hz to 2kHz	-14dB MIN
	2kHz to 3.4kHz	-12dB MIN
	3.4kHz to 4kHz	-8dB MAX
POTS Group Delay	200Hz to 4kHz	200μSec MAX
Longitudinal Balance	100Hz to 4kHz	-46 dB MIN
	4kHz to 30kHz	-25 dB MIN
	30kHz to 1.1MHz	-45 dB MIN
	1.1MHz to 3.0MHz	-30 dB MIN
	3.0MHz to 5.0 MHz	-20 dB MIN
ADSL Insertion Loss	32kHz to 2.2MHz	-55 dB MIN
DC Current		100mA MAX
Total Side Resistance		40Ω MAX
Line Side Impedance	400kHz to 2.2mHz	1.0kΩ MIN

*Notes: Exception - Typical Return Loss meets published ETSI specification TS101-952-1-3.

XDSL Splitter Filter Module

Mechanical

B8049E/B8049ENL

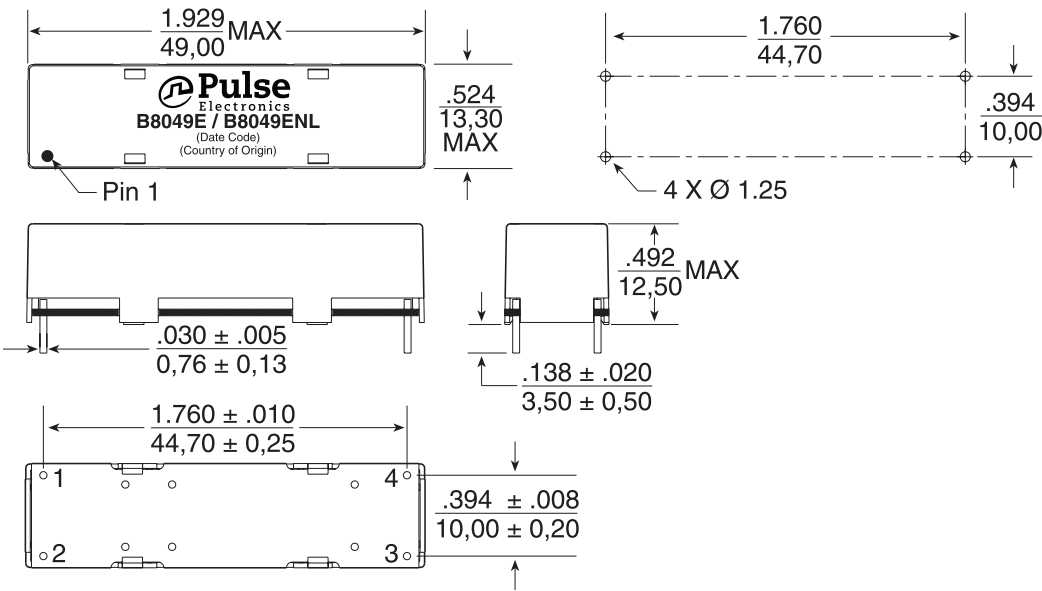

Weight11 grams

Tube35/tube

Dimensions: $\frac{\text{Inches}}{\text{mm}}$

Unless otherwise specified,
all tolerances are $\pm \frac{.010}{0,25}$

Schematic

B8049E/B8049ENL

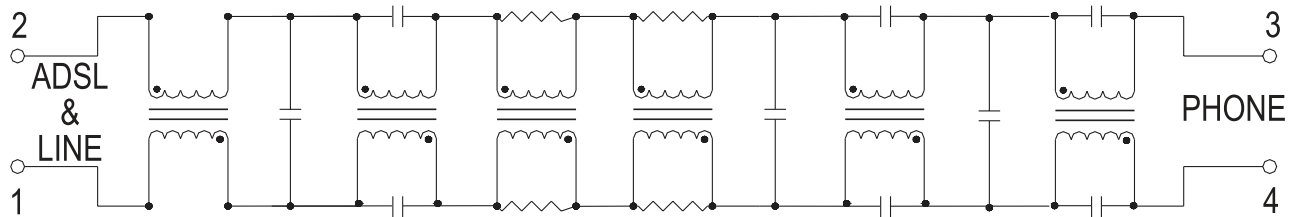

For More Information

Pulse Worldwide Headquarters
12220 World Trade Drive
San Diego, CA
92128
U.S.A.

Pulse Europe
Einsteinstrasse 1
D-71083 Herrenberg
Germany

Pulse China Headquarters
B402, Shenzhen Academy of
Aerospace Technol-
ogy Bldg.
10th Kejinan Road
High-Tech Zone
Nanshan District
Shenzhen, PR China
518057
Tel: 86 755 33966678
Fax: 86 755 33966700

Pulse North China
Room 2704/2705
Super Ocean Finance
Ctr.
2067 Yan An Road
West
Shanghai 200336
China
Tel: 86 21 62787060
Fax: 86 2162786973

Pulse South Asia
135 Joo Seng Road
#03-02
PM Industrial Bldg.
Singapore 368363
Tel: 65 6287 8998
Fax: 65 6287 8998

Pulse North Asia
3F, No. 198
Zhongyuan Road
Zhongli City
Taoyuan County 320
Taiwan R. O. C.
Tel: 886 3 4356768
Fax: 886 3 4356823 (Pulse)
Fax: 886 3 4356820 (FRE)

Performance warranty of products offered on this data sheet is limited to the parameters specified. Data is subject to change without notice. Other brand and product names mentioned herein may be trademarks or registered trademarks of their respective owners. © Copyright, 2012. Pulse Electronics, Inc. All rights reserved.

Mouser Electronics

Authorized Distributor

Click to View Pricing, Inventory, Delivery & Lifecycle Information:

Pulse:

[B8049E](#) [B8049ENL](#) [B8049NL](#)