

Proximity Magnetic Sensors

Magnetic units

CL Series



- Rectangular, cylindrical or trapezoidal housing
- Several dimensions
- Side or front operating mode

Product Description

Magnetic units used for operating magnetic proximity sensors consist of permanent magnets sharply sized for the job they are intended. Their shape can be rectangular or cylindrical. Block-shaped magnetic units must be placed on non-magnetic supports,

their minimum thickness must be in accordance with those one listed in table, in parallel to the switch longitudinal axis.

Ordering Key

CL 2

Magnetic unit
Type

General

Shape	Housing material	Magnetic material*	Minimum separation**	Reference
Rectangular	Plastic	Alnico	10	CL1
	Plastic	Alnico	20	CL2
	Plastic	Alnico	30	CL3
	Plastic	Alnico	50	CL4
Cylindrical	Plastic	Alnico	Not mandatory	CL10
	Plastic	Alnico	Not mandatory	CL11
	-	Ferrite	Not mandatory	CL18
	-	Ferrite	Not mandatory	CL23
	-	Ferrite	Not mandatory	CL31
	-	Ferrite	Not mandatory	CL20S1
	-	Ferrite	Not mandatory	CL20S3
	-	Ferrite	Not mandatory	CL50
Trapezoidal	Plastic	Alnico	Not mandatory	CL90

Distances are specified in millimeters (mm)

* see Magnetic Material Description table for more details.

** minimum distance required between two magnetic units on the same axis.

Magnetic Material Description

The principal materials by which are realized the above mentioned magnetic units can be classified in:

- **Ferrite**: is a mixture made of iron oxide and barium carbonate (or strontium) and is obtained through a dry or wet way sintering process.
- **Alnico**: is a mixture made of iron, aluminum, nickel, cobalt and other elements in lower percentage; it is obtained through fusion and its principal features are the hardness and the relative resistance to hits, the high value of magnetization and the possibility to be used to high temperatures.

Type Selection

Shape	A	B	C	D	E	F	Reference
Rectangular	14	25	2.7	8	-	-	CL1
	12	44.5	2.7	9	-	-	CL2
	18	59	3.2	9	-	-	CL3
	25	76	4.2	10	8	10	CL4
Cylindrical	Ø9.3	M12x1.25	32	10.5	-	-	CL10
	Ø13.5	M18x1.5	65	11	-	-	CL11
	18	3	6	6	-	-	CL18
	23	4.5	9	10	-	-	CL23
	31	4.5	10	10	-	-	CL31
	25.1	4.8	10.5	9.8	-	-	CL20S1
	22.1	4.8	10.5	9.8	-	-	CL20S3
Trapezoidal	50	0	10	0	-	-	CL50
	31	90	6.5	22.5	-	-	CL90

Dimensions are specified in millimeters (mm)

Dimensions

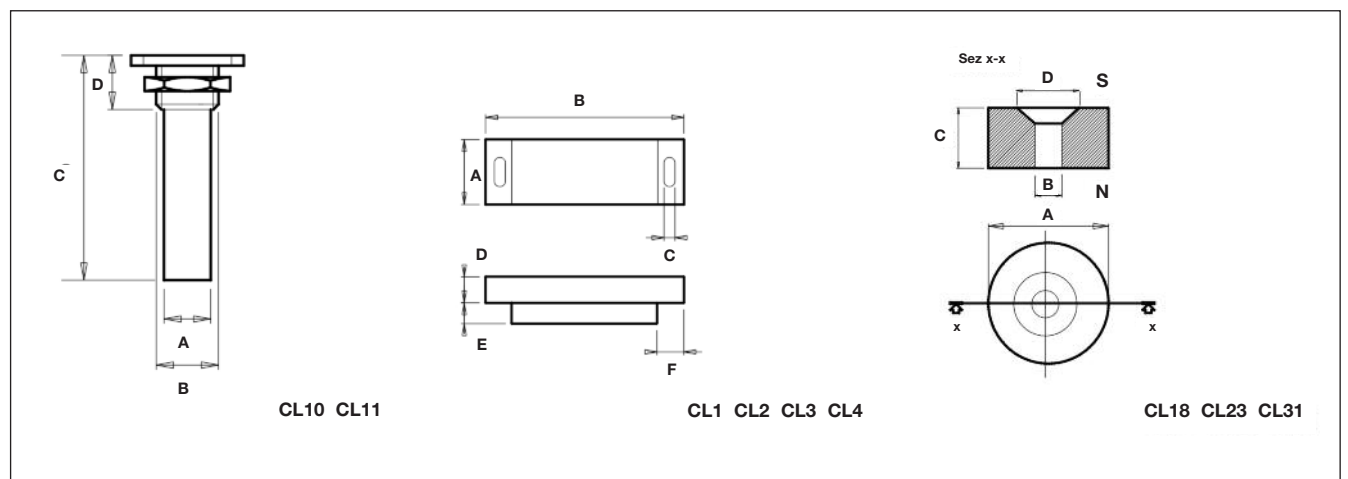

Dimensions (cont.)

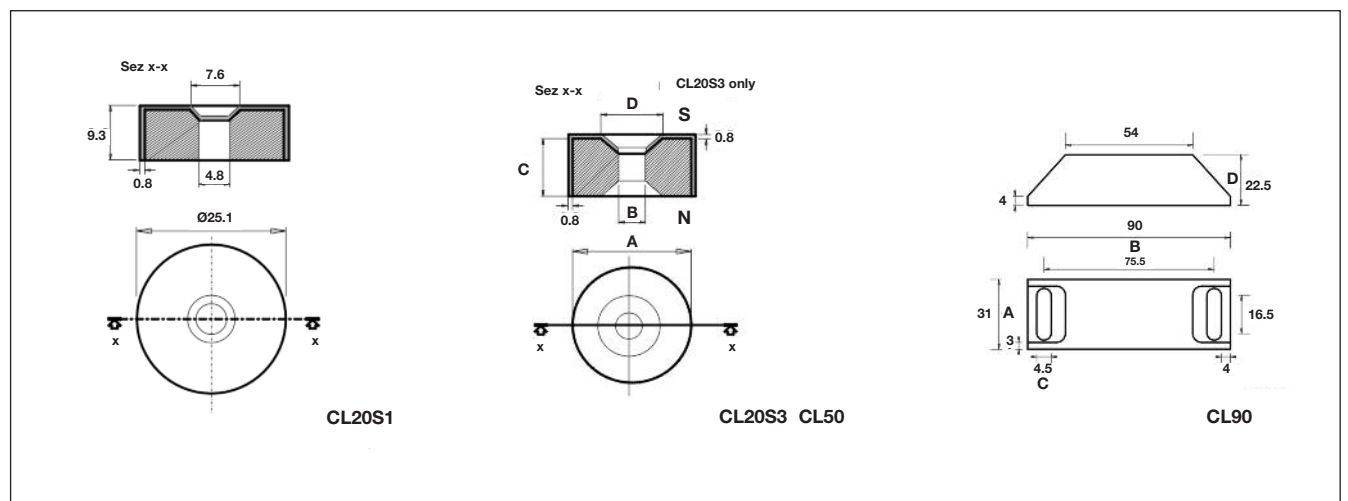

Mouser Electronics

Authorized Distributor

Click to View Pricing, Inventory, Delivery & Lifecycle Information:

[Carlo Gavazzi:](#)

[CL.10](#) [CL3](#) [CL31](#) [CL.4](#) [CL1](#) [CL23](#) [CL.18](#) [CL90](#) [CL2](#) [CL20S3](#) [CL10](#) [CL11](#) [CL18](#) [CL20S1](#) [CL4](#) [CL50](#)