

Description

The ZXRE250 and ZXRE252 are three-terminal adjustable shunt regulators, offering excellent temperature stability and output current handling capability up to 100mA. The output voltage may be set to any chosen voltage between 2.5 and 36 volts by selection of two external divider resistors.

ZXRE250 has the same electrical specifications as the industry standard '431 except that it features a very low minimum cathode current for regulation. The typical value of 40µA makes the parts ideal for very low-power applications.

The devices can be used as a replacement for zener diodes in many applications requiring an improvement in zener performance. The ZXRE250/2 is available in two grades with initial tolerances of 1% and 0.5% for the A and B grades respectively.

Features

- Minimum Cathode Current for Regulation: 40µA (typ)
- Temperature Range: -40°C to +125°C
- Reference Voltage Tolerance at +25°C
 - ZXRE250A: 2.495V ± 1.0%
 - ZXRE250B: 2.495V ± 0.5%
- Low Output Noise
- 0.2Ω Typical Output Impedance
- Sink Current Capability: 0.065mA to 100mA
- Adjustable Output Voltage: V_{REF} to 36V
- **Totally Lead-Free & Fully RoHS Compliant (Notes 1 & 2)**
- **Halogen and Antimony Free. "Green" Device (Note 3)**

Applications

- Opto-Coupler Linearisers
- Shunt Regulators
- Improved Zener
- Variable Reference

Notes:

1. No purposely added lead. Fully EU Directive 2002/95/EC (RoHS) & 2011/65/EU (RoHS 2) compliant.
2. See http://www.diodes.com/quality/lead_free.html for more information about Diodes Incorporated's definitions of Halogen- and Antimony-free, "Green" and Lead-free.
3. Halogen- and Antimony-free "Green" products are defined as those which contain <900ppm bromine, <900ppm chlorine (<1500ppm total Br + Cl) and <1000ppm antimony compounds.

Pin Assignments

ZXRE250

(Top View)

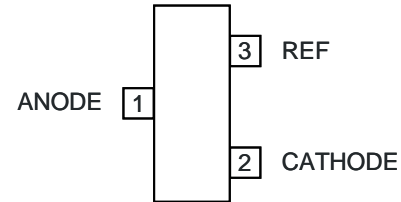

SOT23

(Top View)

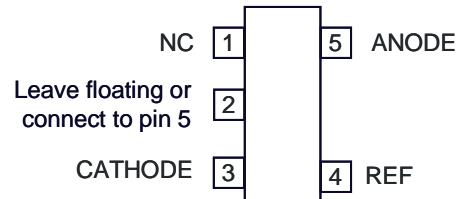

SOT25

ZXRE252

(Top View)

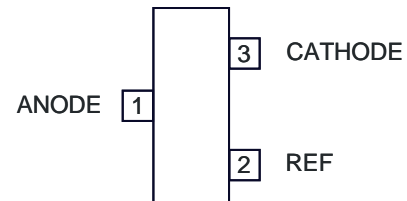

SOT23

Absolute Maximum Ratings (Note 4) (@ $T_A = +25^\circ\text{C}$, unless otherwise specified.)

Symbol	Parameter	Rating	Unit	
V_{KA}	Cathode Voltage	40	V	
I_{KA}	Continuous Cathode Current	150	mA	
I_{REF}	Reference Input Current	-0.050 to +10	mA	
T_J	Operating Junction Temperature	+150	$^\circ\text{C}$	
T_{ST}	Storage Temperature	-55 to +150	$^\circ\text{C}$	
P_D	Power Dissipation (Notes 5 & 6)	SOT23	330	mW
		SOT25	500	mW

- Notes:
4. Operation above the absolute maximum rating may cause device failure. Operation at the absolute maximum ratings, for extended periods, may reduce device reliability. Unless otherwise stated voltages specified are relative to the ANODE pin.
 5. T_J , max = +150 $^\circ\text{C}$
 6. Ratings apply to ambient temperature at +25 $^\circ\text{C}$.

Recommended Operating Conditions (@ $T_A = +25^\circ\text{C}$, unless otherwise specified.)

Symbol	Parameter	Min	Max	Unit
V_{KA}	Cathode Voltage	V_{REF}	36	V
I_{KA}	Cathode Current	0.065	100	mA
T_A	Operating Ambient Temperature	-40	+125	$^\circ\text{C}$

Electrical Characteristics (@ $T_A = +25^\circ\text{C}$, unless otherwise specified.)

Symbol	Parameter	Test Conditions	Min	Typ	Max	Unit	
V_{REF}	Reference Voltage	$V_{KA} = V_{REF}$, $I_{KA} = 10\text{mA}$	ZXRE250A	2.470	2.495	2.520	V
			ZXRE250B	2.482	2.495	2.507	V
V_{DEV}	Deviation of Reference Voltage Over Full Temperature Range (Note 7)	$V_{KA} = V_{REF}$, $I_{KA} = 10\text{mA}$	$T_A = 0$ to +70 $^\circ\text{C}$	-	6	16	mV
			$T_A = -40$ to +85 $^\circ\text{C}$	-	14	34	mV
			$T_A = -40$ to +125 $^\circ\text{C}$	-	14	34	mV
$\frac{\Delta V_{REF}}{\Delta V_{KA}}$	Ratio of the Change in Reference Voltage to the Change in Cathode Voltage	$I_{KA} = 10\text{mA}$	$V_{KA} = 10\text{V}$ to V_{REF}	-	-1.4	-2.7	mV/V
			$V_{KA} = 36\text{V}$ to 10V	-	-1	-2	mV/V
I_{REF}	Reference Input Current	$I_{KA} = 10\text{mA}$, $R1 = 10\text{K}\Omega$, $R2 = \infty$	-	1	4	μA	
ΔI_{REF}	I_{REF} Deviation Over Full Temperature Range (Note 7)	$I_{KA} = 10\text{mA}$, $R1 = 10\text{K}\Omega$, $R2 = \infty$	$T_A = 0$ to +70 $^\circ\text{C}$	-	0.8	1.2	μA
			$T_A = -40$ to +85 $^\circ\text{C}$	-	0.8	2.5	μA
			$T_A = -40$ to +125 $^\circ\text{C}$	-	0.8	2.5	μA
$I_{KA(MIN)}$	Minimum Cathode Current for Regulation	$V_{KA} = V_{REF}$	-	40	65	μA	
$I_{KA(OFF)}$	Off-State Current	$V_{KA} = 36\text{V}$, $V_{REF} = 0\text{V}$	-	0.05	0.5	μA	
$ Z_{KA} $	Dynamic Output Impedance (Note 8)	$V_{KA} = V_{REF}$, $f = 0\text{Hz}$	-	0.2	0.5	Ω	
θ_{JA}	Thermal Resistance Junction to Ambient	SOT23	-	380	-	$^\circ\text{C/W}$	
		SOT25	-	250	-	$^\circ\text{C/W}$	

- Notes:
7. Deviation of V_{DEV} , and ΔI_{REF} are defined as the maximum variation of the values over the full temperature range.
 8. Derivation of Z_{KA} on following page.

Electrical Characteristics (cont.) (@T_A = +25°C, unless otherwise specified.)

The average temperature coefficient of the reference input voltage αV_{REF} is defined as:

$$|\alpha V_{REF}| = \left(\frac{V_{DEV}}{V_{REF} @ 25^{\circ}C} \right) \times 10^6 \text{ ppm/}^{\circ}C$$

Where:

T₂ – T₁ = full temperature change.

αV_{REF} can be positive or negative depending on whether the slope is positive or negative.

Note: 8. The dynamic output impedance, R_z, is defined as:

$$|Z_{KA}| = \frac{\Delta V_{KA}}{\Delta I_{KA}}$$

When the device is programmed with two external resistors R1 and R2, the dynamic output impedance of the overall circuit, is defined as:

$$|Z'| = \frac{\Delta V}{\Delta I} \approx |Z_{KA}| \left(1 + \frac{R1}{R2} \right)$$

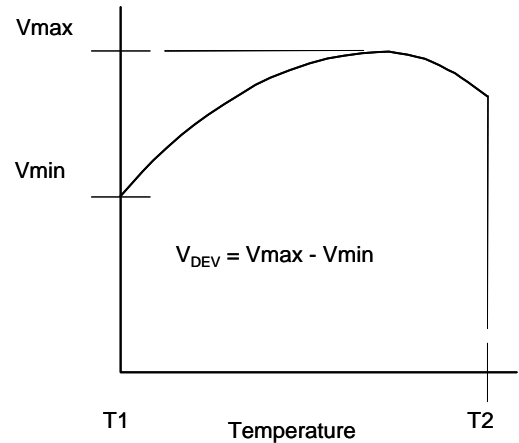

Test Circuits

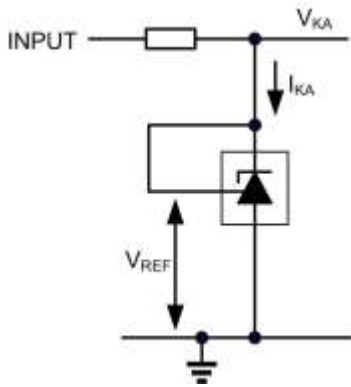

Figure 1 Test Circuit for V_{KA} = V_{REF}

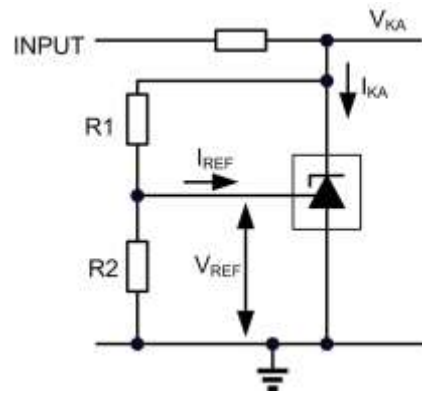

Figure 2 Test Circuit for V_{KA} > V_{REF}

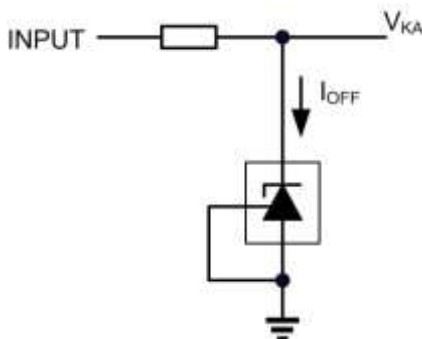
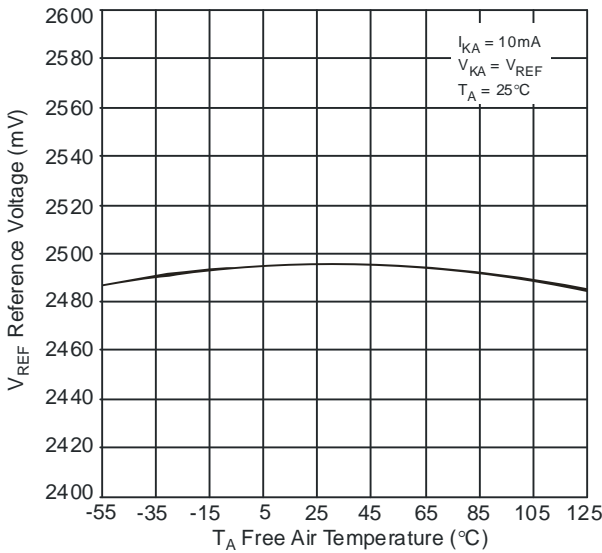
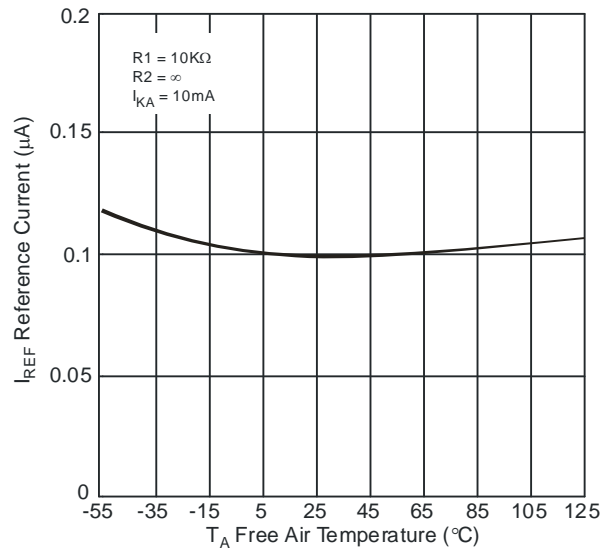

Figure 3 Test Circuit for I_{OFF}

Typical Performance Characteristics



Reference Voltage vs. Free Air Temperature



Reference Current vs. Free Air Temperature

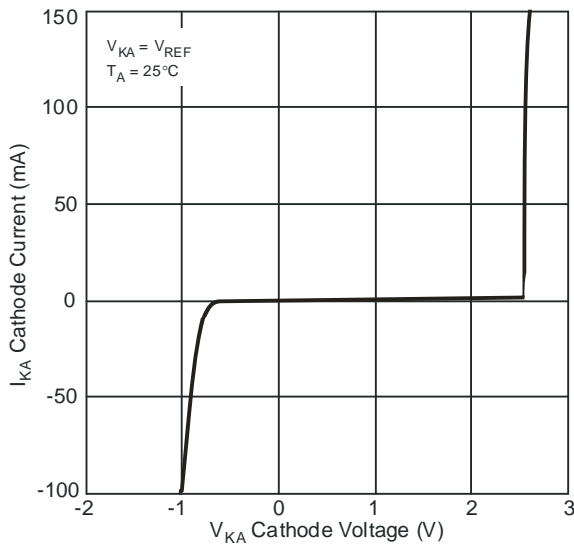

Cathode Current vs. Cathode Voltage

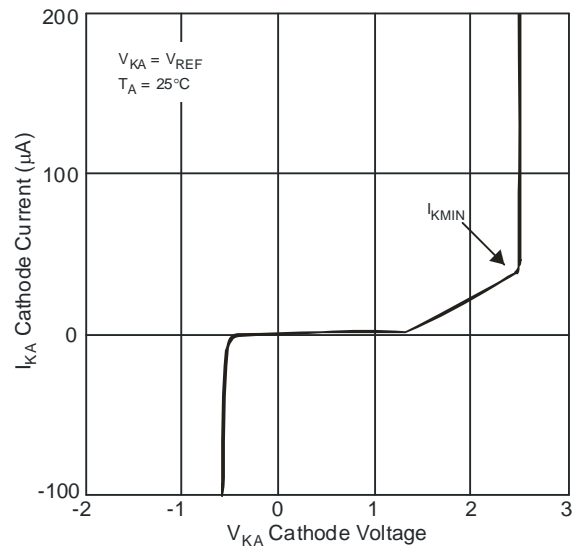

Cathode Current vs. Cathode Voltage

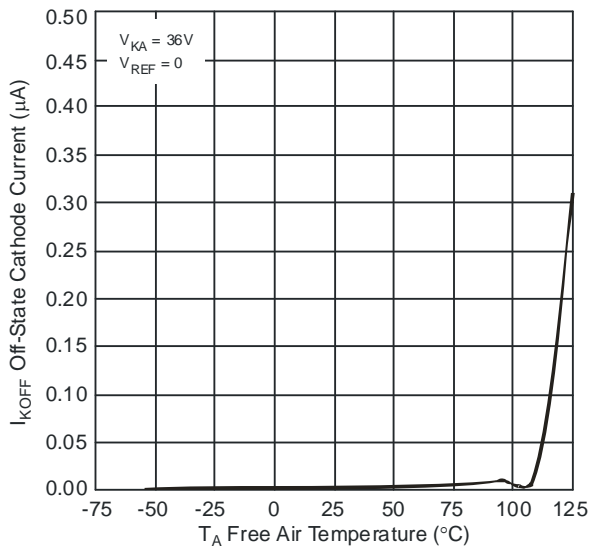

Off-State Cathode Current vs. Free Air Temperature

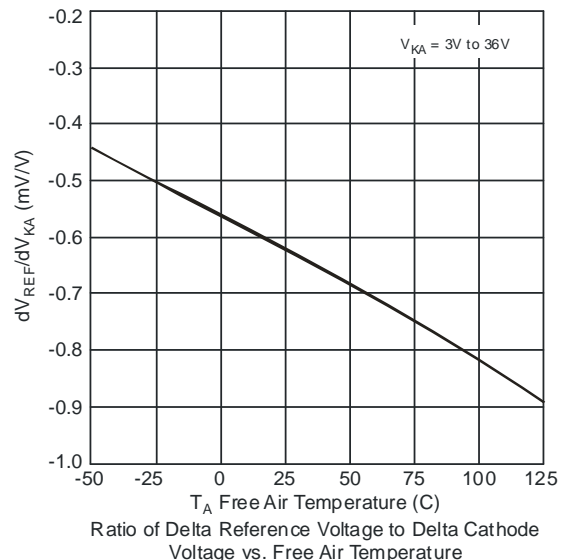

Ratio of Delta Reference Voltage to Delta Cathode Voltage vs. Free Air Temperature

Typical Performance Characteristics (Continued)

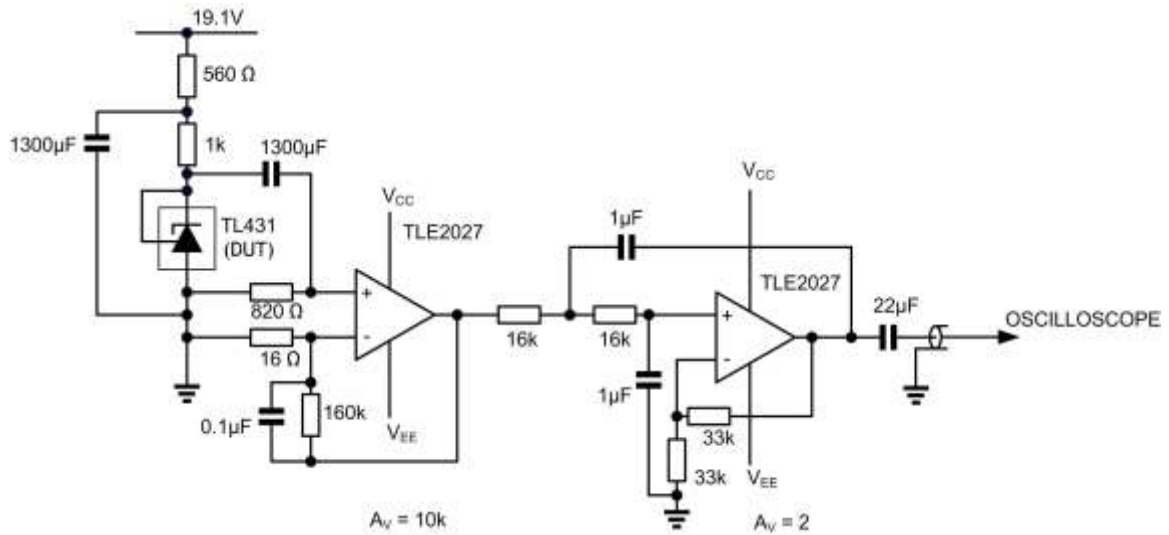
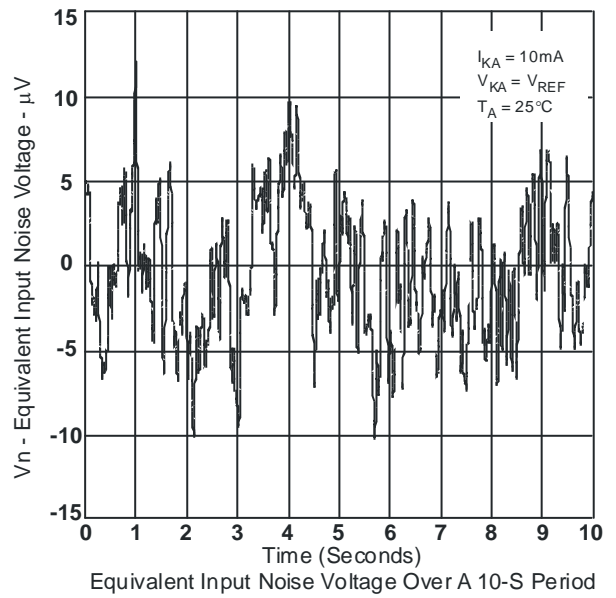
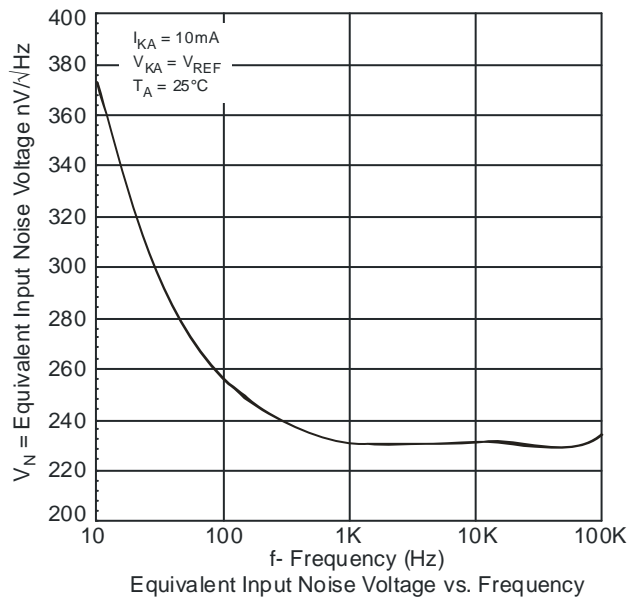
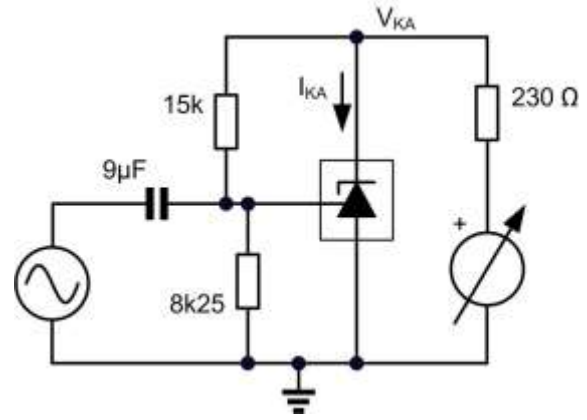
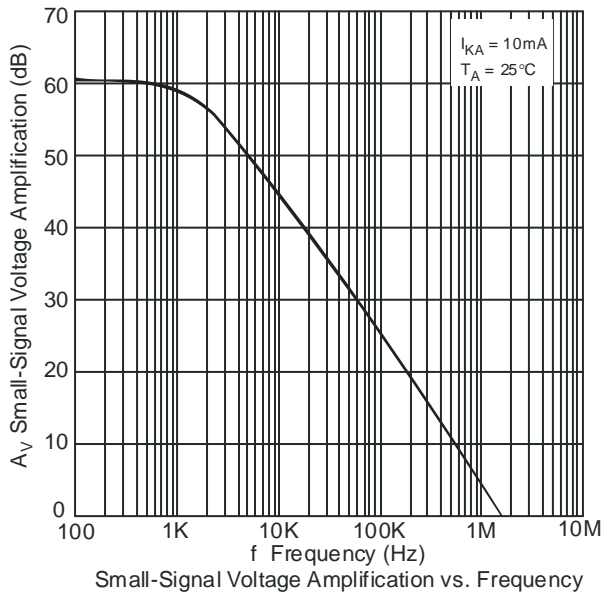
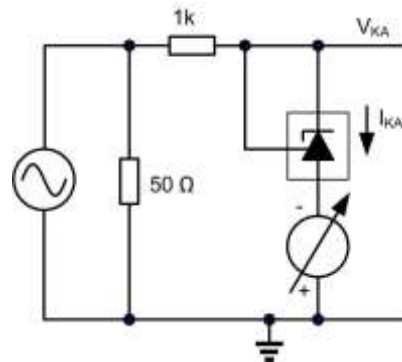
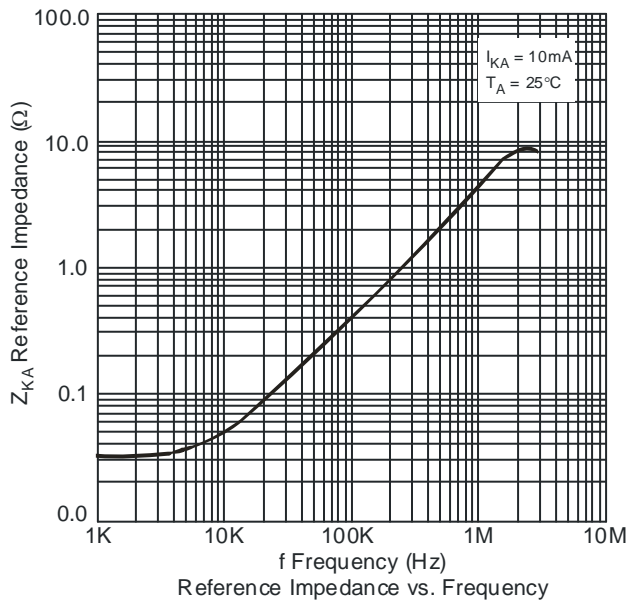

Figure 4 Test Circuit for Noise Input Voltage

Typical Performance Characteristics (Cont.)



Test Circuit for Voltage Amplification



Test Circuit for Reference Impedance

Typical Performance Characteristics (Cont.)

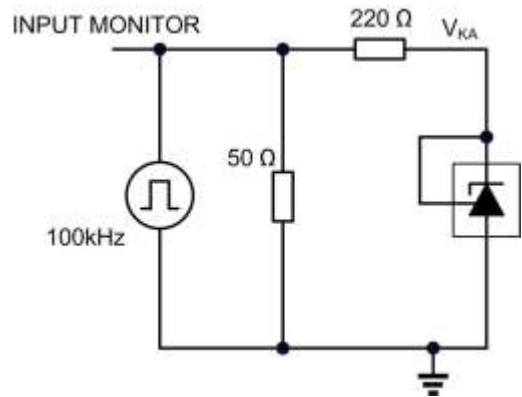
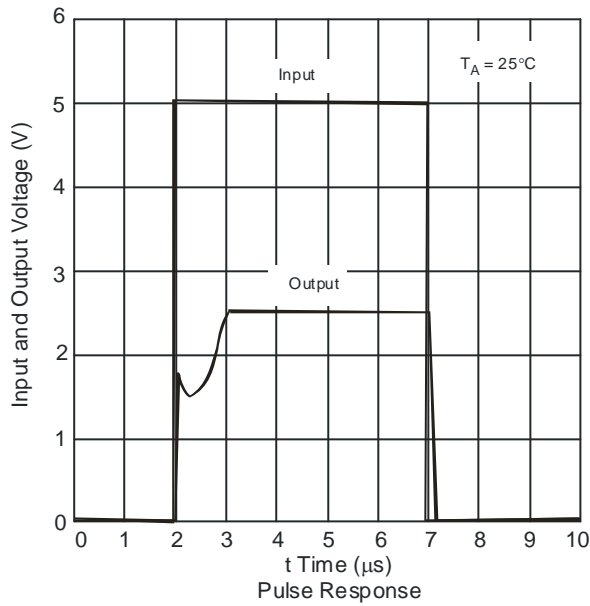

Test Circuit for Pulse Response

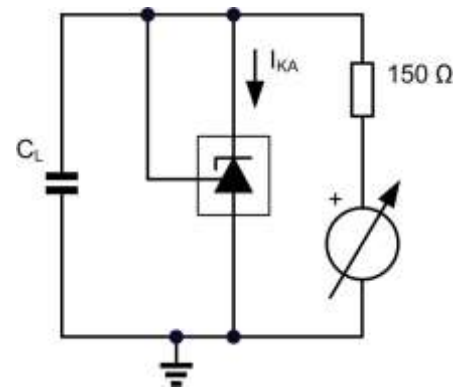
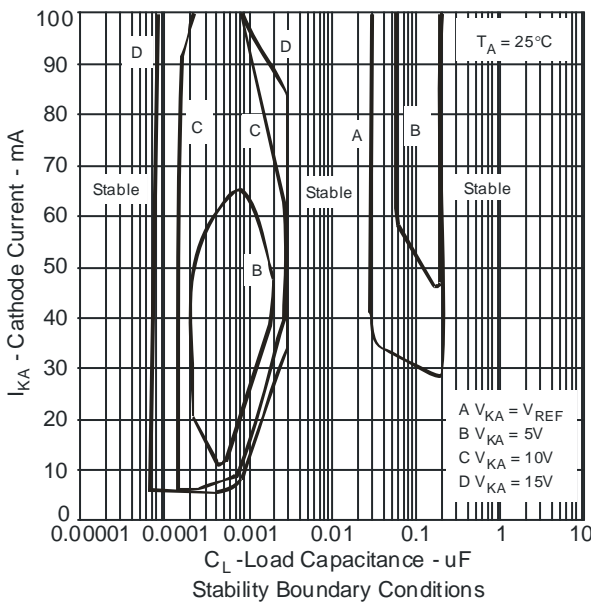

Test Circuit for Curve A

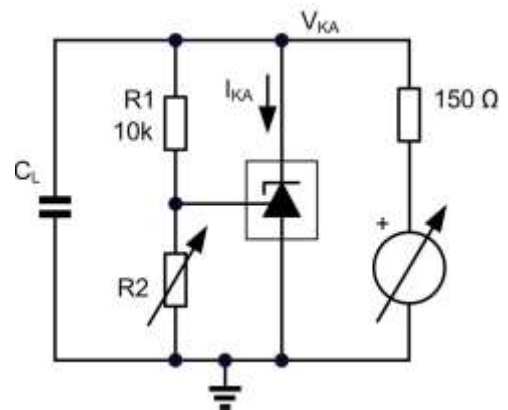

Test Circuit for Curves B, C, D

The device is stable under all conditions with a load capacitance not exceeding 50pF. The device is stable under all conditions with a load capacitance between 5nF and 20nF. The device is stable under all conditions with a load capacitance exceeding 300nF. With a cathode current not exceeding 5mA, the device is stable with any load capacitance.

Application Information

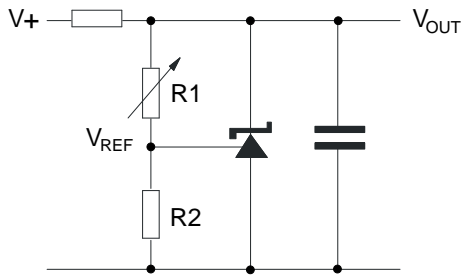

$$V_{OUT} = \left(1 + \frac{R1}{R2}\right) V_{REF}$$

Shunt Regulator

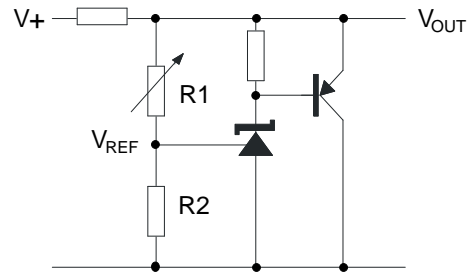

$$V_{OUT} = \left(1 + \frac{R1}{R2}\right) V_{REF}$$

Higher Current Shunt Regulator

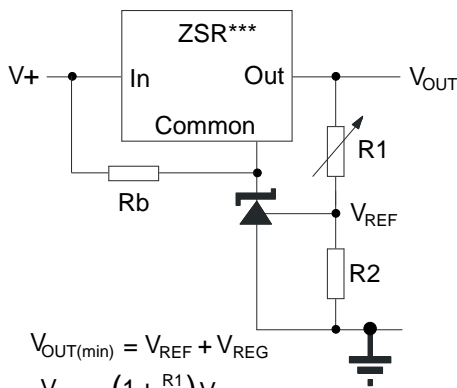

$$V_{OUT(min)} = V_{REF} + V_{REG}$$

$$V_{OUT} = \left(1 + \frac{R1}{R2}\right) V_{REF}$$

Rb - Optional to provide minimum cathode current

Output Control of a Three Terminal Fixed Regulator

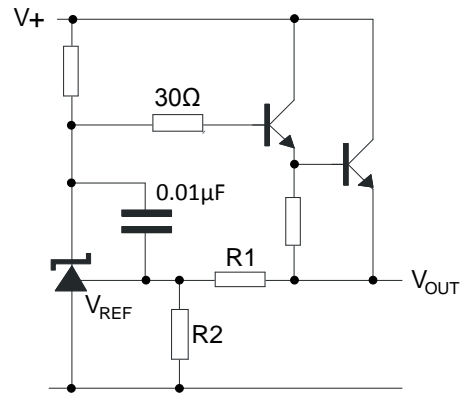

$$V_{OUT} = \left(1 + \frac{R1}{R2}\right) V_{REF}$$

Series Regulator

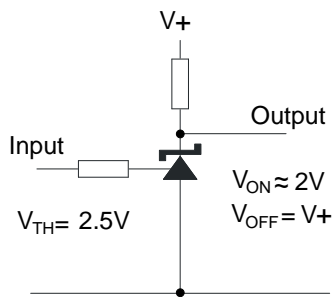

Single Supply Comparator with Temperature Compensated Threshold

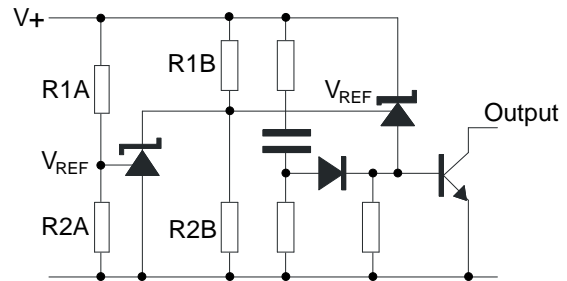

$$\text{Low Limit} = \left(1 + \frac{R1B}{R2B}\right) V_{REF}$$

$$\text{High Limit} = \left(1 + \frac{R1A}{R2A}\right) V_{REF}$$

Over Voltage / Under Voltage Protection Circuit

Ordering Information

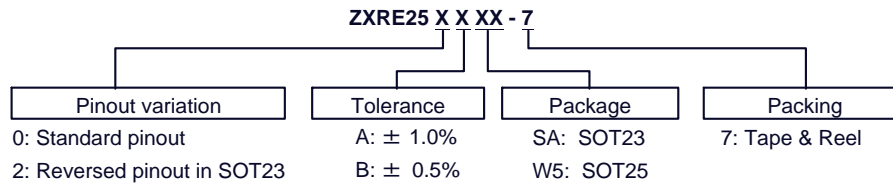

Part Number (Note 9)	Package Code	Packaging	7" Tape and Reel		Ammo Box	
			Quantity	Part Number Suffix	Quantity	Part Number Suffix
ZXRE250A(B)SA-7	SA	SOT23	3,000/Tape & Reel	-7	NA	NA
ZXRE250A(B)W5-7	W5	SOT25	3,000/Tape & Reel	-7	NA	NA
ZXRE252A(B)SA-7	SA	SOT23	3,000/Tape & Reel	-7	NA	NA

Note: 9. Suffix (B) denotes ZXRE250B (0.5% tolerance) device.

Marking Information

(1) SOT23

(Top View)

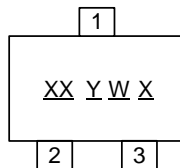

XX : Identification code
Y : Year 0~9
W : Week : A~Z : 1~26 week;
 a~z : 27~52 week; z represents
 52 and 53 week
X : A~Z : Green

Device	Package	Identification Code
ZXRE250ASA	SOT23	DA
ZXRE250BSA	SOT23	DB
ZXRE252ASA	SOT23	FA
ZXRE252BSA	SOT23	FB

(2) SOT25

(Top View)

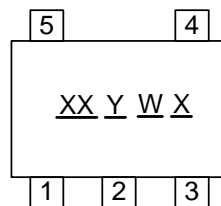

XX : Identification code
Y : Year 0~9
W : Week : A~Z : 1~26 week;
 a~z : 27~52 week; z represents
 52 and 53 week
X : A~Z : Green

Device	Package	Identification Code
ZXRE250AW5	SOT25	DA
ZXRE250BW5	SOT25	DB

Package Outline Dimensions

Please see <http://www.diodes.com/package-outlines.html> for the latest version.

(1) Package type: SOT25

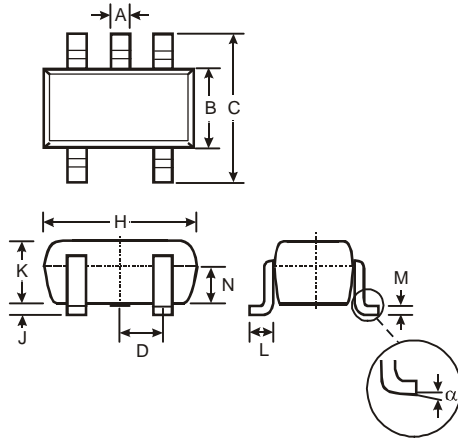

SOT25			
Dim	Min	Max	Typ
A	0.35	0.50	0.38
B	1.50	1.70	1.60
C	2.70	3.00	2.80
D	—	—	0.95
H	2.90	3.10	3.00
J	0.013	0.10	0.05
K	1.00	1.30	1.10
L	0.35	0.55	0.40
M	0.10	0.20	0.15
N	0.70	0.80	0.75
α	0°	8°	—
All Dimensions in mm			

(2) Package Types: SOT23

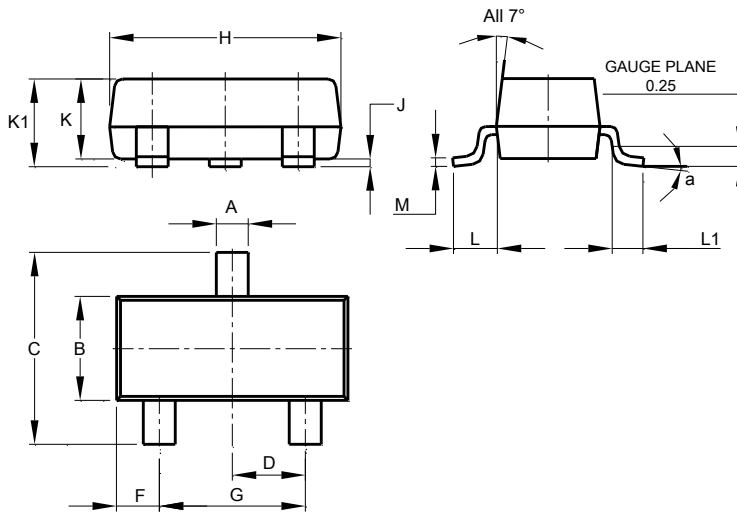

SOT23			
Dim	Min	Max	Typ
A	0.37	0.51	0.40
B	1.20	1.40	1.30
C	2.30	2.50	2.40
D	0.89	1.03	0.915
F	0.45	0.60	0.535
G	1.78	2.05	1.83
H	2.80	3.00	2.90
J	0.013	0.10	0.05
K	0.890	1.00	0.975
K1	0.903	1.10	1.025
L	0.45	0.61	0.55
L1	0.25	0.55	0.40
M	0.085	0.150	0.110
a	8°		
All Dimensions in mm			

Suggested Pad Layout

Please see <http://www.diodes.com/package-outlines.html> for the latest version.

(1) Package type: SOT25

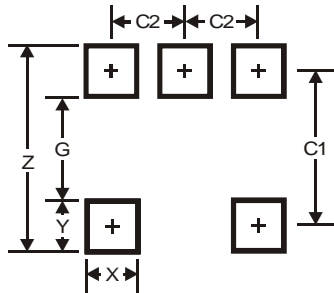

Dimensions	Value (in mm)
Z	3.20
G	1.60
X	0.55
Y	0.80
C1	2.40
C2	0.95

(2) Package Types: SOT23

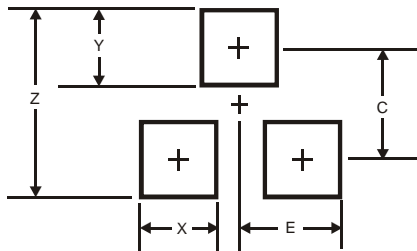

Dimensions	Value (in mm)
Z	2.9
X	0.8
Y	0.9
C	2.0
E	1.35

IMPORTANT NOTICE

DIODES INCORPORATED MAKES NO WARRANTY OF ANY KIND, EXPRESS OR IMPLIED, WITH REGARDS TO THIS DOCUMENT, INCLUDING, BUT NOT LIMITED TO, THE IMPLIED WARRANTIES OF MERCHANTABILITY AND FITNESS FOR A PARTICULAR PURPOSE (AND THEIR EQUIVALENTS UNDER THE LAWS OF ANY JURISDICTION).

Diodes Incorporated and its subsidiaries reserve the right to make modifications, enhancements, improvements, corrections or other changes without further notice to this document and any product described herein. Diodes Incorporated does not assume any liability arising out of the application or use of this document or any product described herein; neither does Diodes Incorporated convey any license under its patent or trademark rights, nor the rights of others. Any Customer or user of this document or products described herein in such applications shall assume all risks of such use and will agree to hold Diodes Incorporated and all the companies whose products are represented on Diodes Incorporated website, harmless against all damages.

Diodes Incorporated does not warrant or accept any liability whatsoever in respect of any products purchased through unauthorized sales channel. Should Customers purchase or use Diodes Incorporated products for any unintended or unauthorized application, Customers shall indemnify and hold Diodes Incorporated and its representatives harmless against all claims, damages, expenses, and attorney fees arising out of, directly or indirectly, any claim of personal injury or death associated with such unintended or unauthorized application.

Products described herein may be covered by one or more United States, international or foreign patents pending. Product names and markings noted herein may also be covered by one or more United States, international or foreign trademarks.

This document is written in English but may be translated into multiple languages for reference. Only the English version of this document is the final and determinative format released by Diodes Incorporated.

LIFE SUPPORT

Diodes Incorporated products are specifically not authorized for use as critical components in life support devices or systems without the express written approval of the Chief Executive Officer of Diodes Incorporated. As used herein:

A. Life support devices or systems are devices or systems which:

1. are intended to implant into the body, or
2. support or sustain life and whose failure to perform when properly used in accordance with instructions for use provided in the labeling can be reasonably expected to result in significant injury to the user.

B. A critical component is any component in a life support device or system whose failure to perform can be reasonably expected to cause the failure of the life support device or to affect its safety or effectiveness.

Customers represent that they have all necessary expertise in the safety and regulatory ramifications of their life support devices or systems, and acknowledge and agree that they are solely responsible for all legal, regulatory and safety-related requirements concerning their products and any use of Diodes Incorporated products in such safety-critical, life support devices or systems, notwithstanding any devices- or systems-related information or support that may be provided by Diodes Incorporated. Further, Customers must fully indemnify Diodes Incorporated and its representatives against any damages arising out of the use of Diodes Incorporated products in such safety-critical, life support devices or systems.

Copyright © 2017, Diodes Incorporated

www.diodes.com

Mouser Electronics

Authorized Distributor

Click to View Pricing, Inventory, Delivery & Lifecycle Information:

[Diodes Incorporated:](#)

[ZXRE252ASA-7](#) [ZXRE252BSA-7](#) [ZXRE250ASA-7](#) [ZXRE250AW5-7](#) [ZXRE250BSA-7](#) [ZXRE250BW5-7](#)