



MAX3161E Evaluation Kit

Evaluates: MAX3161E

General Description

The MAX3161E evaluation kit (EV kit) circuit demonstrates the RS-232/RS-485/RS-422 multiprotocol transceivers using the MAX3161E IC. The circuit can be configured to operate as a dual transceiver in RS-232 mode or as a single transceiver in RS-485/RS-422 mode. The MAX3161E RS-232 data rates can reach 1Mbps, while RS-485/RS-422 data rates can reach 10Mbps. The configurable slew-rate limiting feature reduces data rates for either protocol to achieve reduced EMI.

In RS-485/RS-422 mode, the EV kit demonstrates full-duplex or half-duplex communication. The MAX3161E drivers feature short-circuit and thermal protection as well as fail-safe circuitry for open, shorted, or unconnected RS-485/RS-422 receiver inputs. The MAX3161E EV kit operates from a single 3V to 5.5VDC supply capable of providing 100mA.

Component List

DESIGNATION	QTY	PART DESCRIPTION
C1, C2, C3, C5	4	0.47 μ F \pm 10%, 10V X5R ceramic capacitors (0603) Murata GRM188R61A474K
C4	1	0.1 μ F \pm 10%, 10V X5R ceramic capacitor (0402) Murata GRM155R61A104K
C6	1	10 μ F \pm 10%, 10V X5R ceramic capacitor (0805) Murata GRM21BR61A106K
J1	1	DB9 male right-angle connector
J2	1	5-position terminal block (5mm)
JU1–JU4, JU9, JU10	6	2-pin headers
JU5–JU8	4	3-pin headers
R1–R4	4	100k Ω \pm 5% resistors (0603)
R5, R6	2	120 Ω \pm 1% resistors (1206)
U1	1	MAX3161EEAG+ (24-pin SSOP)
—	10	Shunts (JU1–JU10)
—	1	PCB: MAX3161E Evaluation Kit+

Features

- ◆ 3V to 5.5V Single-Supply Operation
- ◆ Configurable Multiprotocol Operation:
 - 2Tx/2Rx RS-232 Transceivers
 - Single RS-485/RS-422 Transceiver
- ◆ 10Mbps RS-485/RS-422 Data Rates and 1Mbps RS-232 Data Rates
- ◆ Configurable RS-232/RS-485 Transmitter Slew Rates
- ◆ Configurable Full-Duplex/Half-Duplex RS-485/RS-422 Operation
- ◆ Fully Assembled and Tested

Ordering Information

PART	TEMP RANGE	IC PACKAGE
MAX3161EEVKIT+	0°C to +70°C*	24 SSOP

+Denotes a lead-free and RoHS-compliant EV kit.

*This limited temperature range applies to the EV kit PCB only. The MAX3161E IC temperature range is -40°C to +85°C.

Component Supplier

SUPPLIER	PHONE	WEBSITE
Murata Mfg. Co., Ltd.	770-436-1300	www.murata.com

Note: Indicate that you are using the MAX3161E when contacting this component supplier.

MAX3161E Evaluation Kit

Quick Start

Recommended Equipment

- 3.3V, 0.5A DC power supply
- Logic function generator
- Oscilloscope

Procedure

The MAX3161E EV kit is fully assembled and tested. Follow the steps below to verify board operation. **Caution: Do not turn on the power supply until all connections are completed.**

- 1) Verify that shunts are installed across pins 1-2 of jumpers JU5–JU8 (data communications equipment (DCE) mode).
- 2) Verify that a shunt is installed on jumpers JU3 (RS-232 mode) and JU4 (full-duplex mode).
- 3) Verify that shunts are not installed on jumpers JU1 (MAX3161E enabled), JU2 (fast mode), and JU9 and JU10 (RS-485/RS-422 differential I/O not terminated).
- 4) Set the DC power-supply output to 3.3V and disable the output.
- 5) Set the logic function generator to a 3.3V_{P-P}, 500kHz, 1.65V_{DC} offset square wave and disable the output. Terminate the function generator as needed.
- 6) Connect the DC power-supply positive output to the VCC pad on the EV kit.
- 7) Connect the supply ground to the GND pad next to VCC on the EV kit.
- 8) Connect the logic function generator output to the DI/T1IN PCB pad and connect ground to the GND PCB pad.
- 9) Enable the power-supply output and then the function generator output.
- 10) Use the oscilloscope to measure the transmitter output T1OUT at pin 3 of jumper JU5. Verify that the waveform is a 500kHz square wave and is approximately $\pm 5V_{P-P}$.

Detailed Description

The MAX3161E EV kit demonstrates the MAX3161E RS-232/RS-485/RS-422 multiprotocol transceiver IC. The EV kit operates from a 3V to 5.5VDC source capable of supplying 100mA.

The EV kit features jumpers to configure the communication protocol to RS-232 operation or RS-485/RS-422 operation. In RS-232 mode operation, the MAX3161E communicates at data rates up to 1Mbps. In RS-485/RS-422 mode operation, the differential driver and

receiver operate in full-duplex or half-duplex mode and communicate at data rates up to 10Mbps. The MAX3161E receiver represents a 1/8 unit load on the RS-485/RS-422 bus. Resistors R5 and R6 provide a configurable termination for the RS-485/RS-422 bus.

Terminal block J2 eases connection to the RS-485/RS-422 bus. The DB9 connector J1 is available for interfacing with an RS-232 serial line. See Table 5 and Figures 1, 2, and 3 for the respective signal pins or pads.

Jumper Selection

The MAX3161E EV kit utilizes several jumpers to reconfigure circuit features and functionality: IC enable, slew-rate selection, communication-protocol selection, full-duplex/half-duplex communication, DTE/DCE connections, and RS-485/RS-422 differential I/O termination.

Enable

The MAX3161E EV kit features jumper JU1 to enable the MAX3161E or place the IC in shutdown mode, thus reducing quiescent current. A $\overline{\text{SHDN}}$ PCB pad is also provided for the shutdown signal to interface with an external controller. See Table 1 for configuring jumper JU1.

Table 1. MAX3161E Enable (Jumper JU1)

SHUNT POSITION	$\overline{\text{SHDN}}$ PIN	EV KIT FUNCTION
Installed	Connected to GND	MAX3161E shutdown
Not installed	Connected to VCC through resistor R1	MAX3161E enabled

Slew-Rate Selection

Jumper JU2 on the EV kit configures the MAX3161E communication slew-rate mode. Slew-rate limited-mode operation minimizes EMI radiation, while fast-mode operation optimizes maximum data rates for either protocol. See Table 2 for configuring jumper JU2 and refer to the MAX3161E IC data sheet for more information on slew-rate configuration.

Table 2. Slew Rate (Jumper JU2)

SHUNT POSITION	FAST PIN	EV KIT FUNCTION
Installed	Connected to GND	Slew-rate limited mode. RS-232/RS-485/RS-422 250kbps maximum data rate
Not installed	Connected to VCC through resistor R2	Fast mode. RS-232 1Mbps maximum data rate; RS-485/RS-422 10Mbps maximum data rate

MAX3161E Evaluation Kit

Evaluates: MAX3161E

RS-232/RS-485/RS-422 Protocol Selection

EV kit jumper JU3 sets the communication protocol to either RS-232 or RS-485/RS-422. See Table 3 for configuring jumper JU3. For additional protocol-configuration information, refer to the *Functional Diagrams* section of the MAX3161E IC data sheet.

RS-485/RS-422 Communication Mode

EV kit jumper JU4 configures the MAX3161E IC's RS-485/RS-422 communication mode to full duplex or half duplex. To receive RS-485 data, disable the RS-485 outputs by driving the DE485/T2IN PCB pad low. See Table 4 to configure jumper JU4 for the desired mode of communication.

Header J2 is labeled for full-duplex RS-485/RS-422 communication; however, the driver outputs (Y and Z) are multiplexed with the receiver inputs (A and B) during half-duplex communication. Refer to the *Half-Duplex RS-485/RS-422 Operation* and *MAX3161E Functional Diagram* sections of the MAX3161E IC data sheet for further details.

DTE/DCE Connections

The EV kit features jumpers JU5, JU6, JU7, and JU8 to configure the RS-232 connector J1 as a data terminal equipment (DTE) or as a data communications equipment (DCE) connector. See Table 5 for configuring the respective jumpers for DTE or DCE connection mode.

RS-485/RS-422 Termination

EV kit jumpers JU9 and JU10 configure the RS-485/RS-422 termination. JU9 sets the input termination with resistor R6. JU10 sets the output termination with resistor R5. See Table 6 for the RS-485/RS-422 termination options.

EV Kit I/O Connections

The MAX3161E EV kit features PCB pads for interfacing with logic signals and DB9 connector J1 to interface with an RS-232 serial line. Terminal block J2 eases connection to an RS-485/RS-422 bus. See Figures 1 or 2 for RS-232 or RS-485/RS-422 transceiver functional modes. The RS-232/RS-485/RS-422 input range is $\pm 25V$ and the output range is $\pm 5V$.

Table 3. RS-232/RS-485/RS-422 Protocol (Jumper JU3)

SHUNT POSITION	RS-485/RS-232 PIN	EV KIT FUNCTION
Installed	Connected to GND	RS-232 mode
Not installed	Connected to VCC through resistor R3	RS-485/RS-422 mode

Table 4. Communication Mode (Jumper JU4)

SHUNT POSITION	HDPLX PIN	RS-485/RS-422 MODE
Installed	Connected to GND	Full-duplex mode
Not installed	Connected to VCC through resistor R4	Half-duplex mode

Table 5. DTE/DCE Modes (Jumpers JU5–JU8)

SHUNT POSITION	JU5	JU6	JU7	JU8	J1 CONNECTION MODE
	J1 PIN 2 CONNECTED TO	J1 PIN 3 CONNECTED TO	J1 PIN 7 CONNECTED TO	J1 PIN 8 CONNECTED TO	
1-2	R1IN	T1OUT	T2OUT	R2IN	DCE
2-3	T1OUT	R1IN	R2IN	T2OUT	DTE

Table 6. RS-485/RS-422 Termination (Jumpers JU9 and JU10)

SHUNT POSITION	JU9	JU10	TERMINATION VALUE
	RS-485 INPUT	RS-485 OUTPUT	
Installed	A connected to B through resistor R6	Y connected to Z through resistor R5	120 Ω termination
Not installed	Not connected	Not connected	—

MAX3161E Evaluation Kit

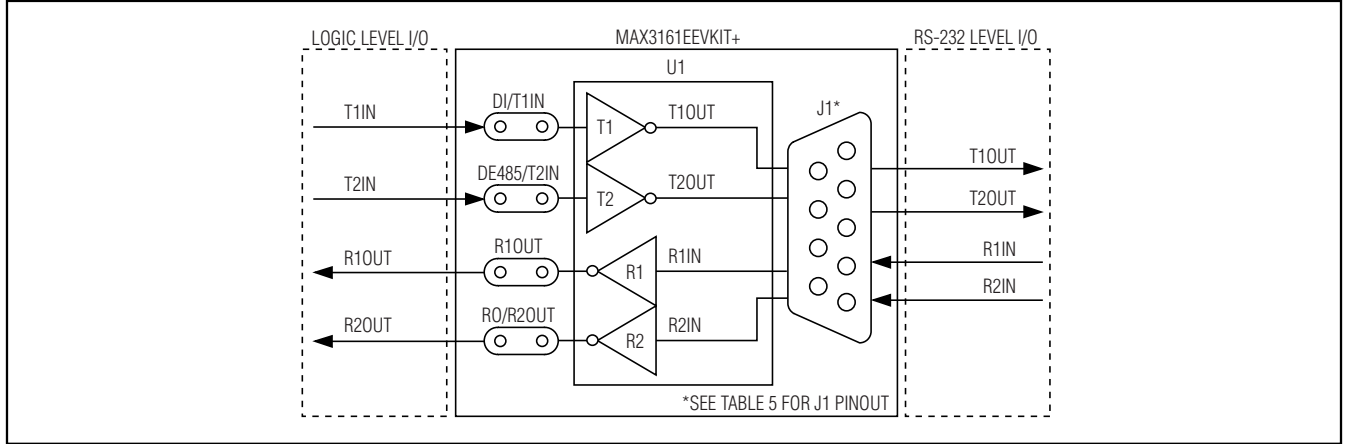

Figure 1. MAX3161E EV Kit I/O Function in RS-232 Mode

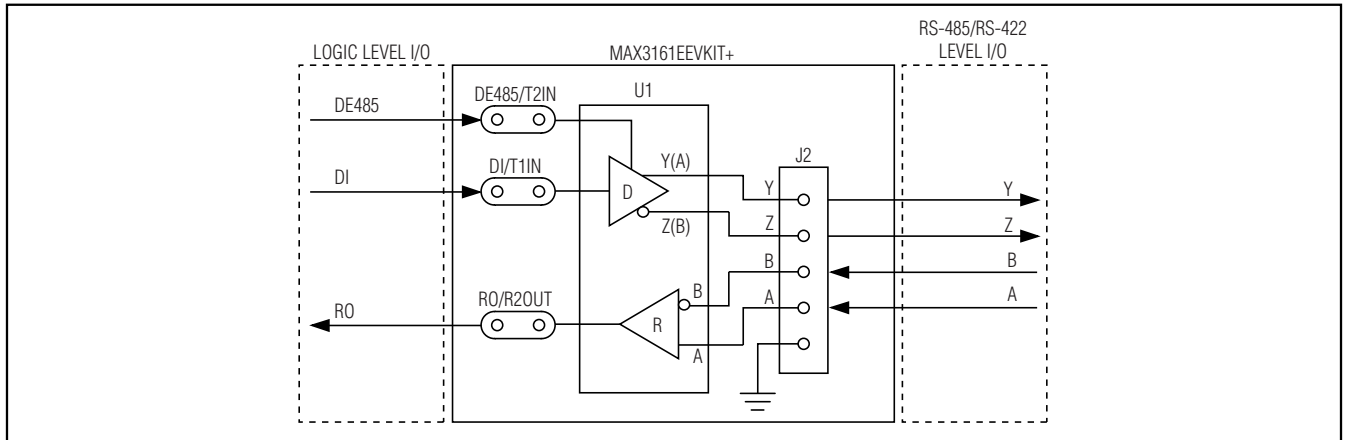

Figure 2. MAX3161E EV Kit I/O Function in RS-485/RS-422 Mode (Full Duplex)

MAX3161E Evaluation Kit

Evaluates: MAX3161E

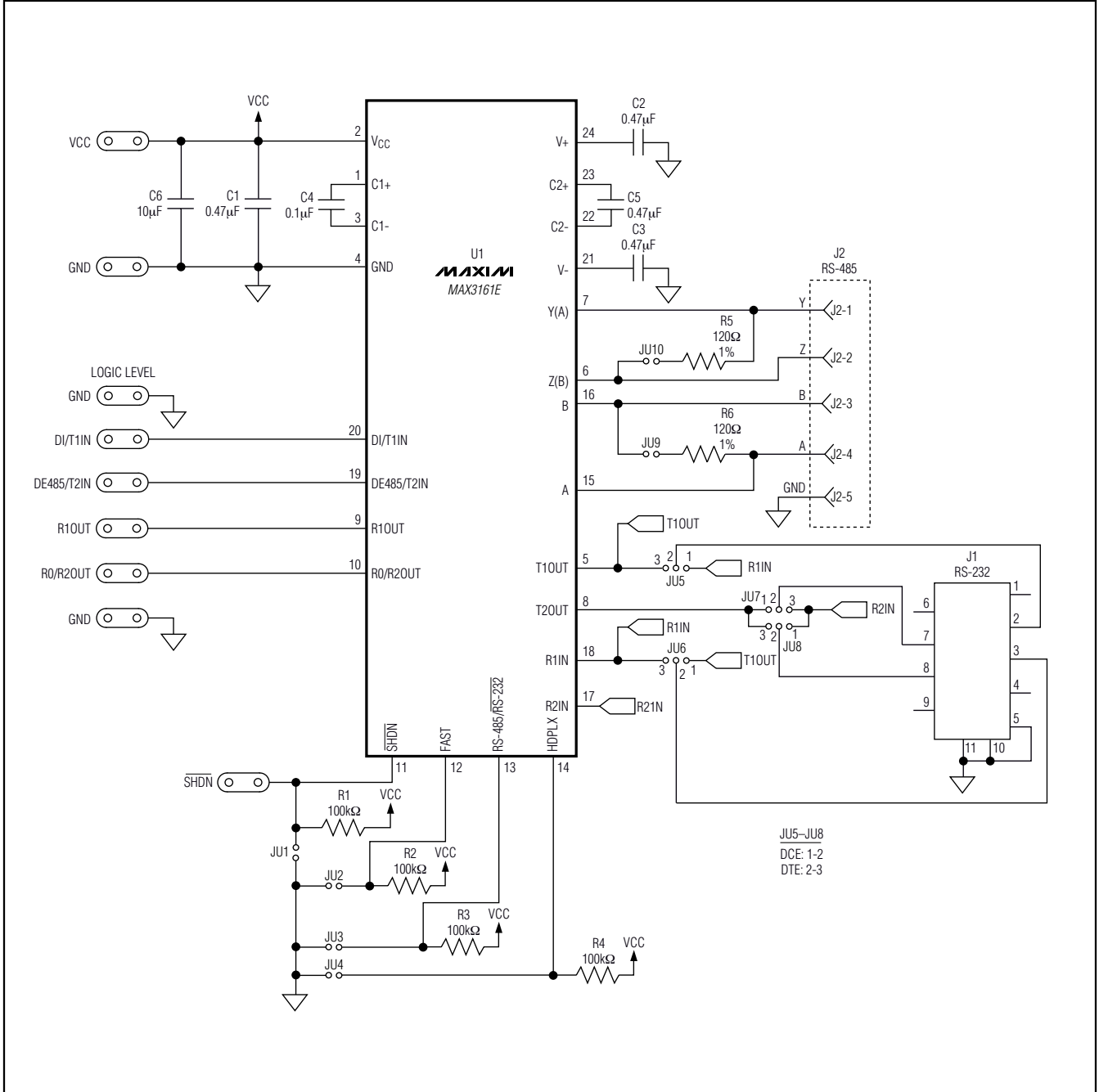

Figure 3. MAX3161E EV Kit Schematic

MAX3161E Evaluation Kit

Evaluates: MAX3161E

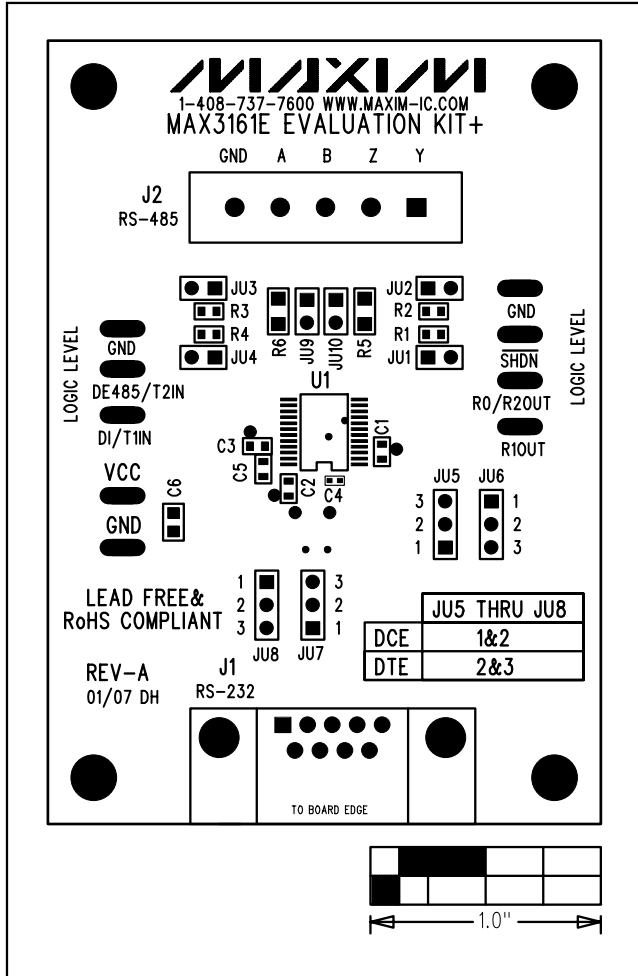

Figure 4. MAX3161E EV Kit Component Placement Guide—Component Side

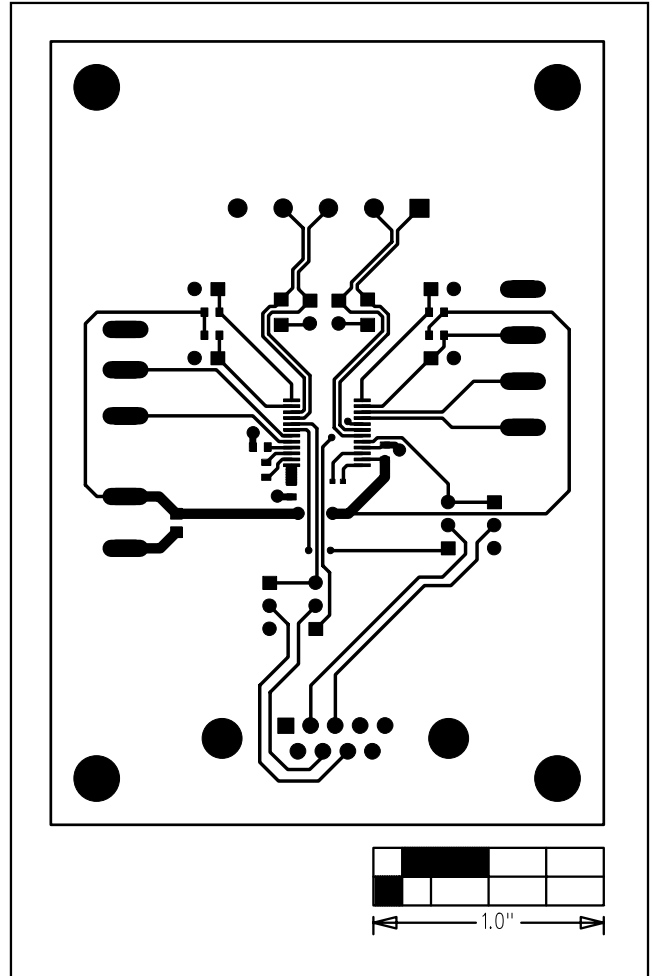

Figure 5. MAX3161E EV Kit PCB Layout—Component Side

MAX3161E Evaluation Kit

Evaluates: MAX3161E

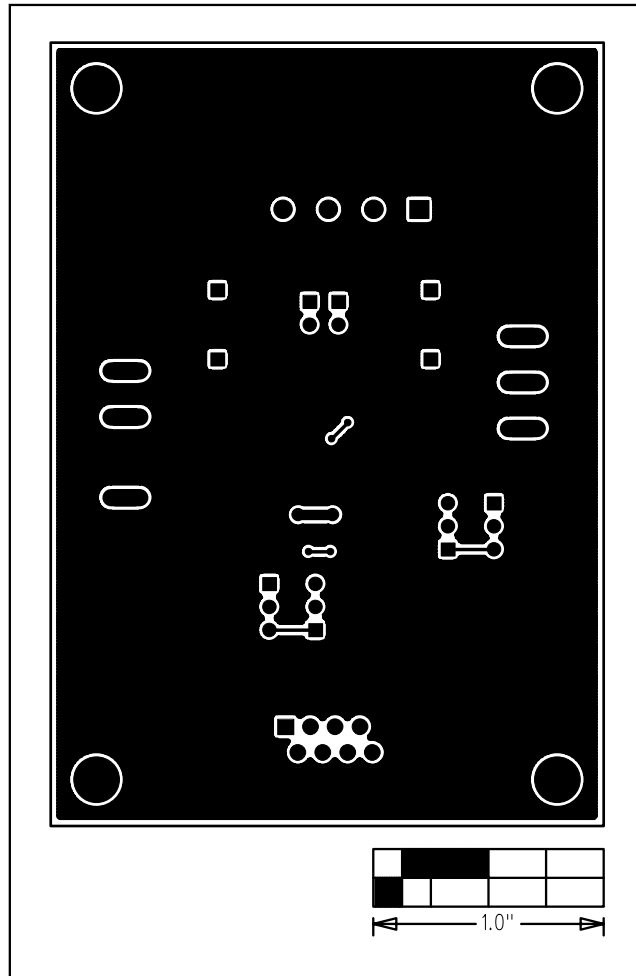

Figure 6. MAX3161E EV Kit PCB Layout—Solder Side

Maxim cannot assume responsibility for use of any circuitry other than circuitry entirely embodied in a Maxim product. No circuit patent licenses are implied. Maxim reserves the right to change the circuitry and specifications without notice at any time.

Maxim Integrated Products, 120 San Gabriel Drive, Sunnyvale, CA 94086 408-737-7600 _____ 7

Mouser Electronics

Authorized Distributor

Click to View Pricing, Inventory, Delivery & Lifecycle Information:

[Maxim Integrated:](#)

[MAX3161EEVKIT+](#)