

THIS DRAWING IS UNPUBLISHED. RELEASED FOR PUBLICATION
 © COPYRIGHT - By - ALL RIGHTS RESERVED.

LOC	DIST	REVISIONS			
P	LTR	DESCRIPTION	DATE	DWN	APVD
GE	00	B1	REVISED PER ECO-11-005030	11MAR11	RK HMR

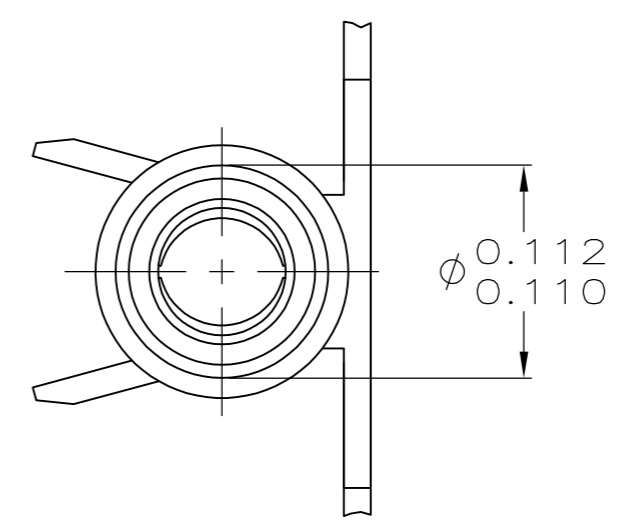

- ① FINISH: PLATE 0.000100-0.000200 THK TIN IN LOCALIZED TIN PLATE AREA, ALL OVER 0.000030-0.000070 THK NICKEL.
SLEEVE: PASSIVATE PER SPEC. 112-230-2, METHOD I.
- 2. CONTACT WILL BE LUBED WITH LUBRICANT PER P/N 22014-4.
- 3. WIRE RANGE: 18-14 AWG SXL, GXL, AND TXL WIRE WITH INSL DIAMETERS OF 0.077-0.155 INCHES.
- 4. SLEEVE MUST WITHSTAND PULL-OFF FORCE IN DIRECTION PARALLEL TO CENTER OF TERMINAL OF 10 LBS. MINIMUM.
- ⑤ PLATE 0.000030 MIN THK SELECT GOLD IN LOCALIZED PLATE AREA.
- ⑥ FINISH: PLATE 0.000100-0.000200 THK TIN IN LOCALIZED TIN PLATE AREA, ALL OVER 0.000040-0.000080 THK NICKEL.
- ⑦ BODY MATERIAL: 0.014 THK COPPER ALLOY
SLEEVE MATERIAL: 0.007 THK STAINLESS STEEL

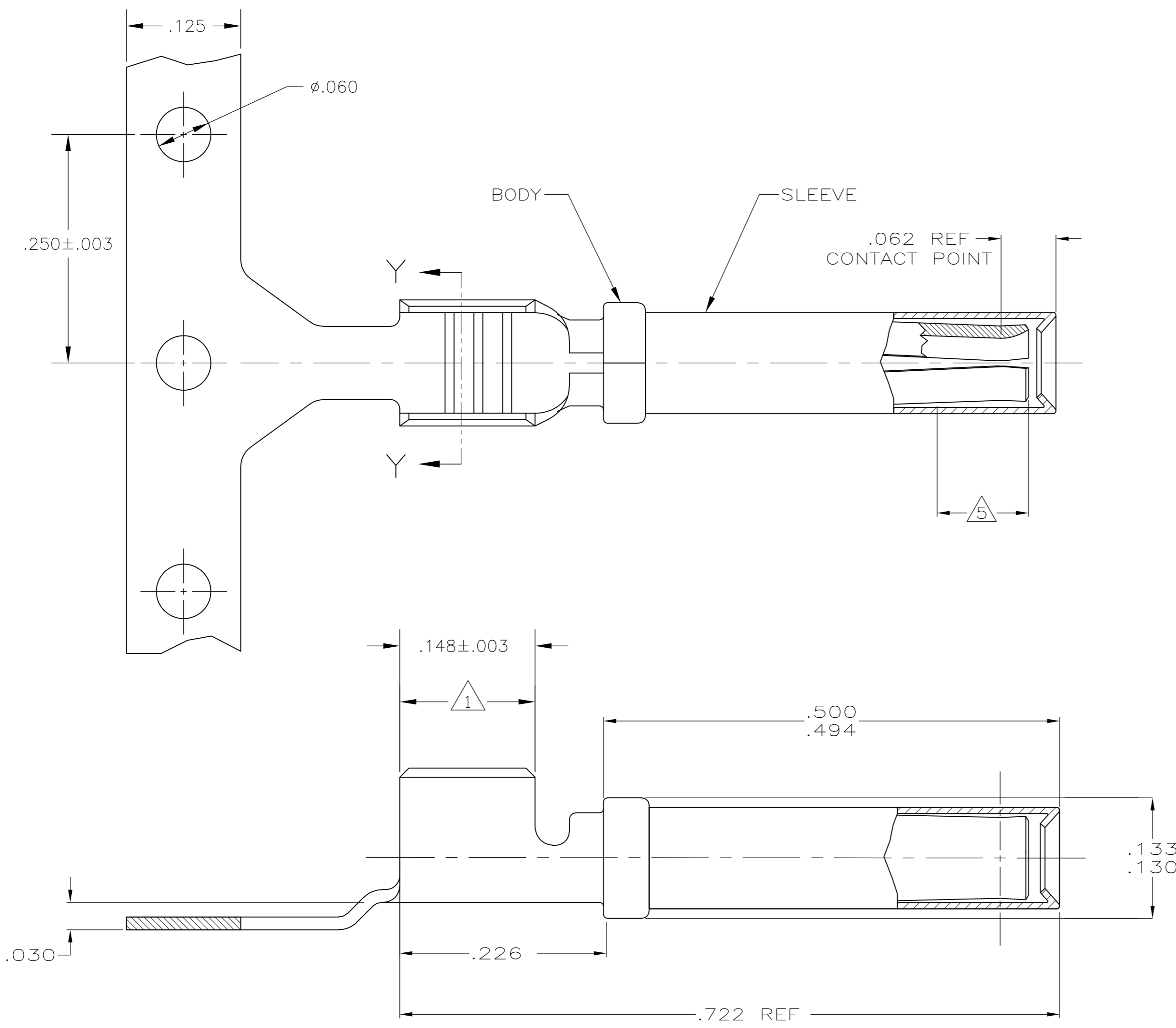
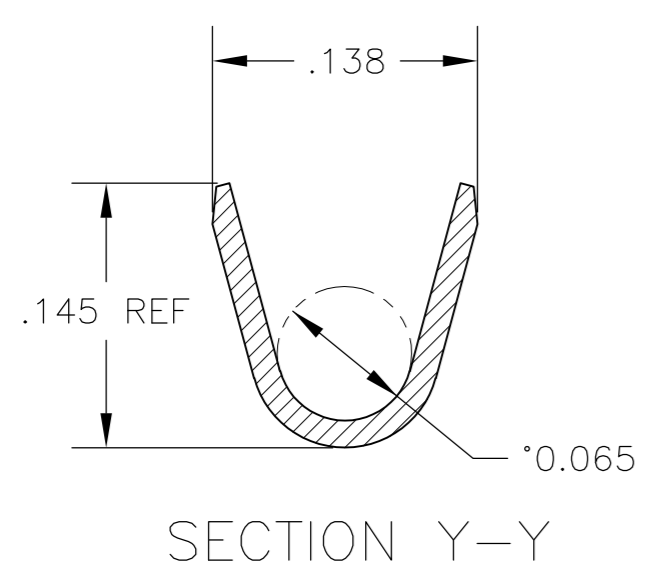

⑥	776491-2
① ⑤	776491-1
FINISH	PART NUMBER

THIS DRAWING IS A CONTROLLED DOCUMENT.		DWN	JR BUSSARD	13DEC2002		TE Connectivity		
DIMENSIONS: INCHES		CHK	MP TRULL	13DEC2002		ASSEMBLY, SOCKET CONTACT, TXL WIRE		
TOLERANCES UNLESS OTHERWISE SPECIFIED:		APVD	MP TRULL	13DEC2002		SIZE	CAGE CODE	DRAWING NO
0 PLC ± - 1 PLC ± - 2 PLC ± .02 3 PLC ± .005 4 PLC ± - ANGLES ± - FINISH		PRODUCT SPEC				A2	00779	C=776491
MATERIAL	⑦	WEIGHT	-		SCALE	10:1	SHEET 1 of 1	
CUSTOMER DRAWING		RESTRICTED TO		REV		B1		

Mouser Electronics

Authorized Distributor

Click to View Pricing, Inventory, Delivery & Lifecycle Information:

[TE Connectivity:](#)

[776491-1](#)