

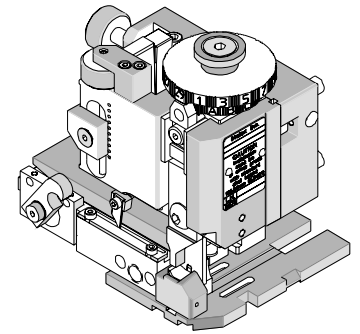

Mini-Mac Applicator Specification Sheet Order No. 63892-2000



FEATURES

- Directly adapts to most automatic wire processing machines
- Applicator designed to industry standard mounting and shut height 135.80mm (5.346")
- Quick set-up time; plus the crimp height, track and feed adjustments can be set without removing the applicator from the press
- Fine adjustment allows users to achieve target with little effort by adjusting in increments of .015mm (.0006") for conductor crimp height and .063mm (.0025") for insulation height
- Independent adjustment rings allow users to quickly adjust the conductor or insulation crimp height without affecting each other.

SCOPE

Products: KK® Female Crimp Terminal, 18-24 AWG.

Terminal Series No.	Terminal Order No		Wire Size		Insulation Diameter		Strip Length	
			AWG	mm ²	mm	In.	mm	In.
1797	08-01-0101	08-05-0101	18-24	0.80-0.20	2.79 Max.	.110 Max.	3.05-3.56	.120-.140
	08-01-0121	08-05-0103						
	08-01-0123	08-07-0101						
	08-03-0101							
4366	08-03-0303	08-05-0305	18-24	0.80-0.20	2.79 Max.	.110 Max.	3.05-3.56	.120-.140
	08-05-0301	40-01-1194						

DEFINITION OF TERMS

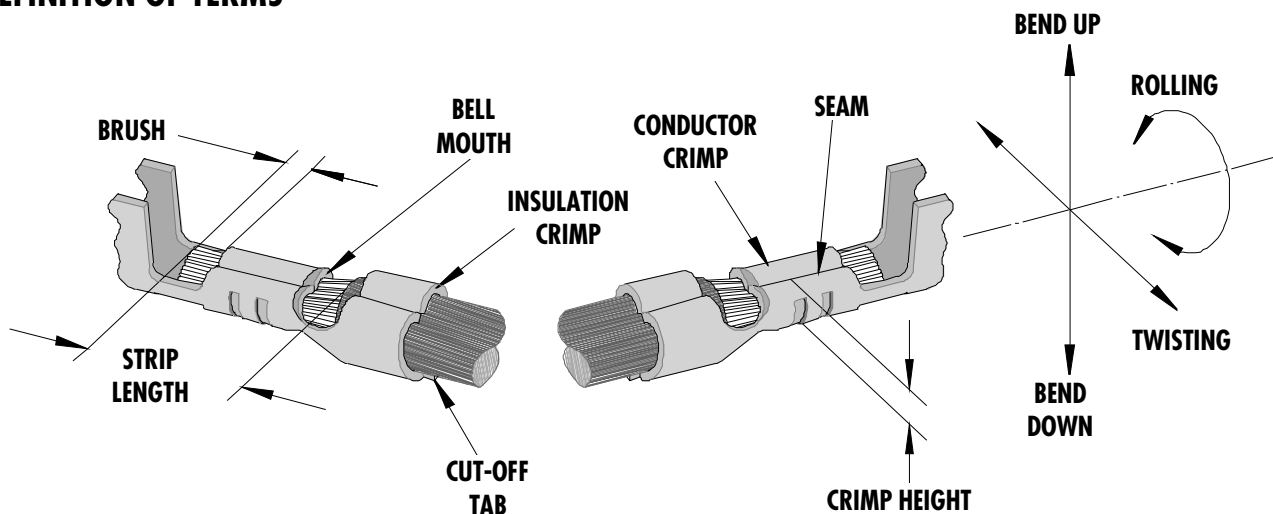

The above terminal drawing is a generic terminal representation. It is not an image of a terminal listed in the scope.

CRIMP SPECIFICATIONS

Terminal Series No.	Wire Size		Bell mouth		Cut-off Tab Maximum		Conductor Brush	
	AWG	mm ²	mm	In.	mm	In.	mm	In.
1797	18-24	0.80-0.20	0.25-0.38	.010-.015	0.25	.010	0.25-0.76	.010-.030
4366	18-24	0.80-0.20	0.25-0.38	.010-.015	0.25	.010	0.25-0.76	.010-.030

Terminal Series No.	Wire Size		Bend up	Bend down	Twist	Roll	Punch Width mm (Ref)			
	AWG	mm ²	Degree		Degree		Conductor		Insulation	
			mm	In	mm	In	mm	In		
1797	18-24	0.80-0.20	3	3	5	5	1.95	.077	2.82	.111
4366	18-24	0.80-0.20	3	3	5	5	1.95	.077	2.82	.111
Seam										
Seam shall not be open and no wire allowed out of the crimping area.										

After crimping, the conductor profile should measure the following.

Terminal Series No.	Wire Size		Conductor				Pull Force Minimum	
			Crimp Height		Crimp Width (Ref.)			
	AWG	mm ²	mm	In.	mm	In.	N	Lb.
1797	18	0.80	1.09-1.14	.043-.045	1.93-2.06	.076-.081	111.2	25.00
	20	0.50	1.04-1.09	.041-.043	1.93-2.06	.076-.081	66.7	15.00
	22	0.35	0.96-1.02	.038-.040	1.93-2.01	.076-.079	53.4	12.00
	24	0.20	0.91-0.96	.036-.038	1.93-2.01	.076-.079	35.6	8.00
4366	18	0.80	1.09-1.14	.043-.045	1.93-2.06	.076-.081	111.2	25.00
	20	0.50	1.04-1.09	.041-.043	1.93-2.06	.076-.081	66.7	15.00
	22	0.35	0.96-1.02	.038-.040	1.93-2.01	.076-.079	53.4	12.00
	24	0.20	0.91-0.96	.036-.038	1.93-2.01	.076-.079	35.6	8.00

Pull Force should be measured with no influence from the insulation crimp.

The above specifications are guidelines to an optimum crimp.

PARTS LIST

Mini-Mac Applicator 63892-2000				
Item	Order No	Engineering No.	Description	Quantity
Perishable Tooling				
	63892-2070	63892-2070	Tool Kit (All "Y" Items)	REF
1	11-18-4267	60720-8	Conductor Punch	1 Y
2	11-18-4265	60720-6	Combination Anvil	1 Y
3	11-18-4266	60720-7	Insulation Punch	1 Y
4	11-18-4264	60720-5	Front Cut-Off Plunger	1 Y
5	11-18-4240	60710-17	Front Cut-off Plunger Retainer	1 Y
Other Components				
6	11-17-2152	7163-14	Hold Down Pad	1
7	11-18-4022	60704-10	Hold Down Adapter	1
8	11-18-4064	60710-4	Front Cut-off Punch	1
9	11-18-4083	60707-8	Feed Guide	1
10	11-18-4261	60720-2	Cover Plate	1
11	11-18-4262	60720-3	Anvil Mounting Block	1
12	11-18-4263	60720-4	Insulation Punch Spacer	1
13	11-24-1067	4996-4	Cut-off Plunger Spring	1
14	63443-0090	63443-0090	Wire Stop	1
15	63803-5127	63803-5127	Conductor Bushing	1
Frame				
16	63801-3201	63801-3201	Top	1
17	63801-3282	63801-3282	Base	1
18	63801-6550	63801-6550	Track	1
Hardware				
19	N/A	N/A	M3 by 8 Long SHCS	2**
20	N/A	N/A	M4 by 6 Long SHCS	1**
21	N/A	N/A	M4 by 10 Long BHCS	2**
22	N/A	N/A	M4 by 12 Long SHCS	2**
23	N/A	N/A	M5 by 10 Long SHCS	1**
24	N/A	N/A	M8 by 20 Long BHCS	1**
25	N/A	N/A	#6-32 by 3/8 Long BHCS	4**
26	N/A	N/A	#6-32 by 1/2 Long FHCS	1**
27	N/A	N/A	#6-32 Hex Jam Nut	1**
28	N/A	N/A	#8-32 by 3/4 Long SHCS	2**

** Available from an industrial supply company such as MSC (1-800-645-7270).

Assembly Drawing

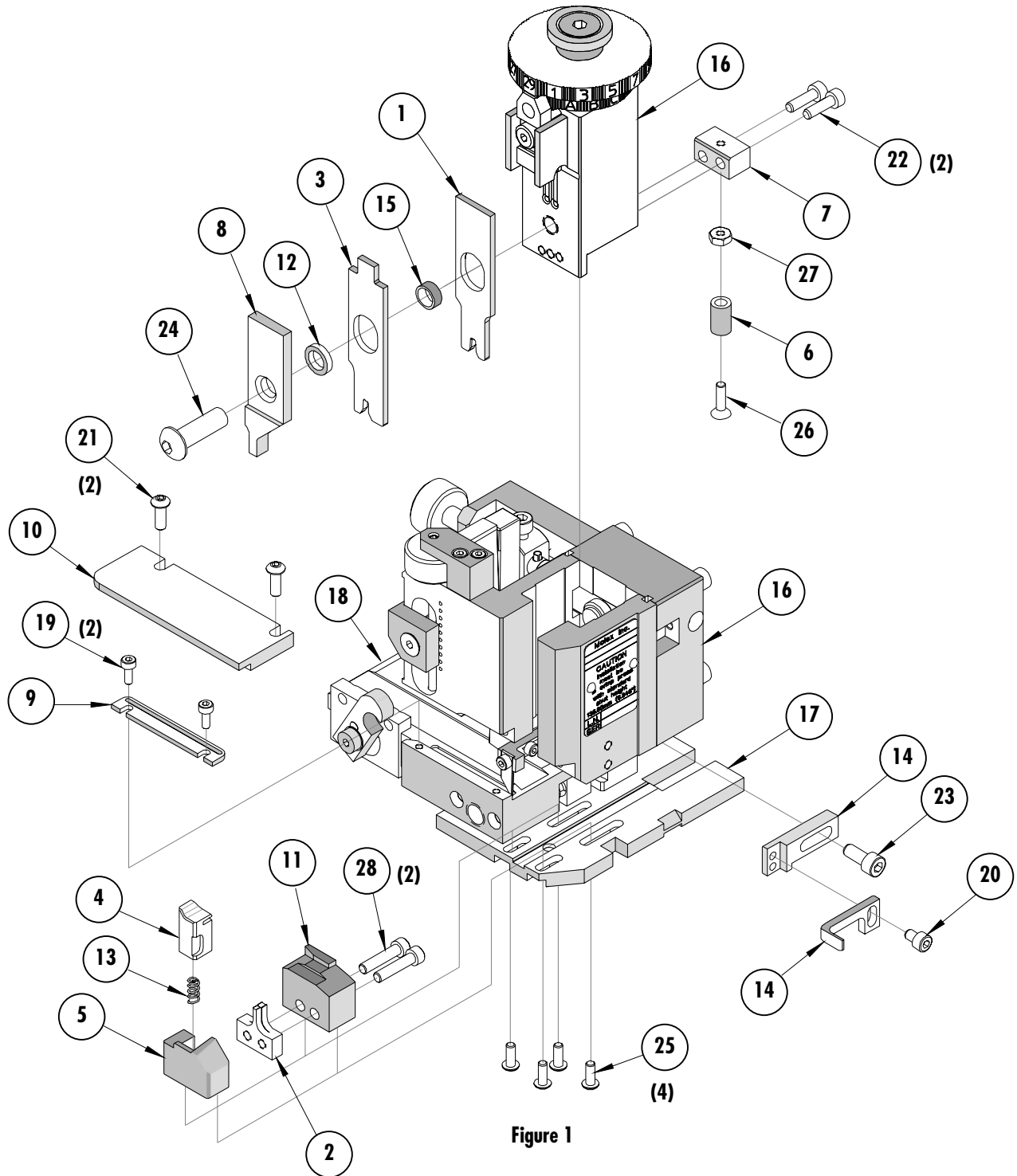

NOTES

1. Molex recommends an extra perishable tooling kit be maintained at your facility.
2. Verify tooling alignment by manually cycling the press and applicator before crimping under power. Check that all screws are tight.
3. Slugs, terminals, dirt, and oil should be kept clear of work area.
4. Wear safety glasses at all times.
5. For recommended maintenance refer to the Mini-Mac Manual.

CAUTION: This applicator should only be used in a press with a shut height of 135.80 mm (5.346"). Tooling damage could result at a lower setting

CAUTION: To prevent injury, never operate this applicator without the guards supplied with the press or wire-processing machine in place. Reference the press or wire processing manufacturer's instruction manual.

CAUTION: Molex crimp specifications are valid only when used with Molex terminals, applicators and tooling.

Contact Information

For more information on Molex application tooling please contact Molex at 1-800-786-6539.

Americas Headquarters

Lisle, Illinois 60532 U.S.A.
1-800-78MOLEX
amerinfo@molex.com

Far East North Headquarters

Yamato, Kanagawa, Japan
81-462-65-2324
feninfo@molex.com

Far East South Headquarters

Jurong, Singapore
65-6-268-6868
fesinfo@molex.com

European Headquarters

Munich, Germany
49-89-413092-0
eurinfo@molex.com

Corporate Headquarters

2222 Wellington Ct.
Lisle, IL 60532 U.S.A.
630-969-4550
Fax: 630-969-1352

Visit our Web site at <http://www.molex.com>

Mouser Electronics

Authorized Distributor

Click to View Pricing, Inventory, Delivery & Lifecycle Information:

[Molex:](#)

[63892-2070](#)