

THIS DRAWING IS UNPUBLISHED. RELEASED FOR PUBLICATION
 © COPYRIGHT - By - ALL RIGHTS RESERVED.

LOC	DIST	REVISIONS			
P	LTR	DESCRIPTION	DATE	DWN	APVD
GP	00	A1	REVISED PER ECO-11-004835	11MAR11	RK HMR

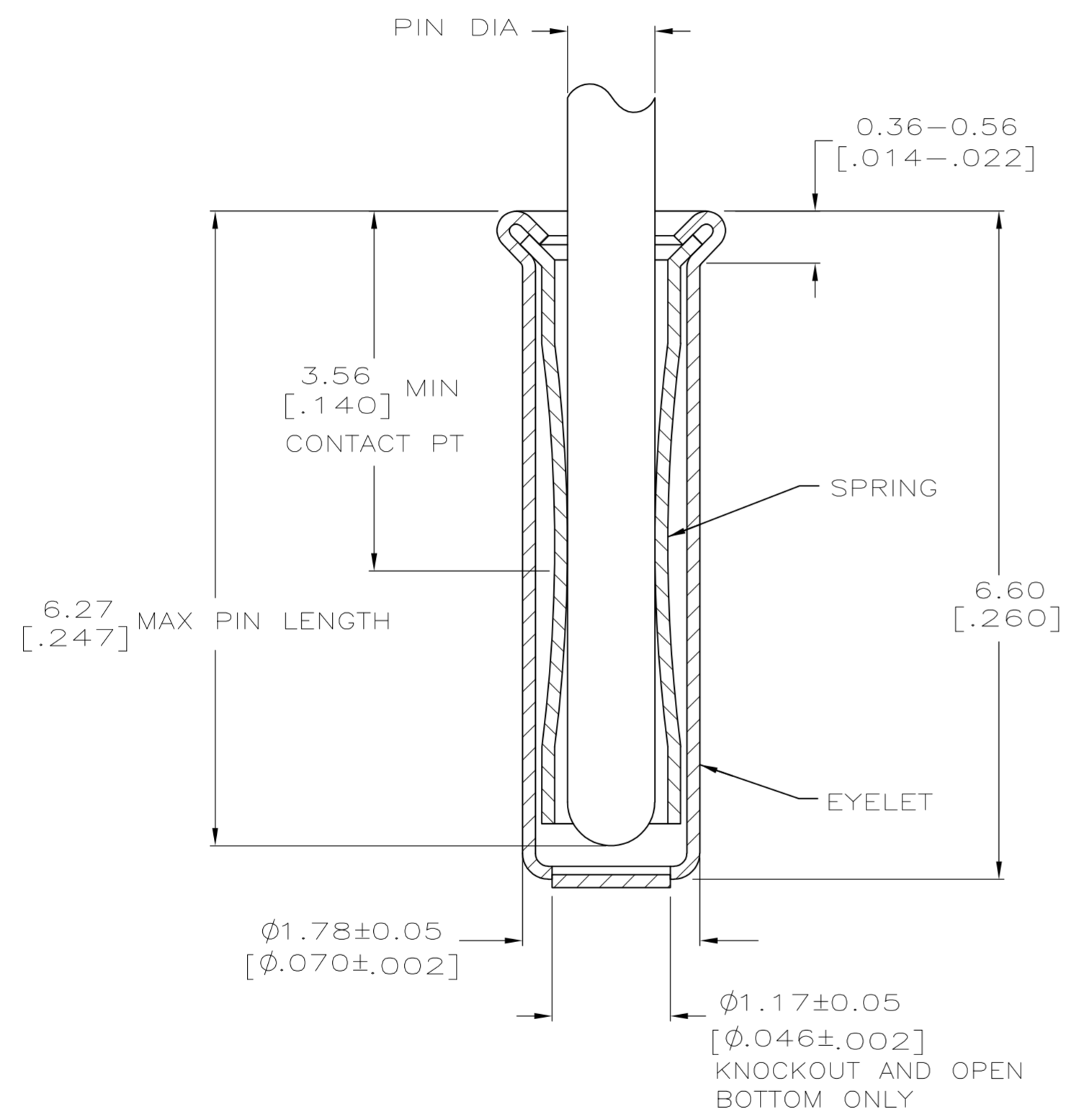
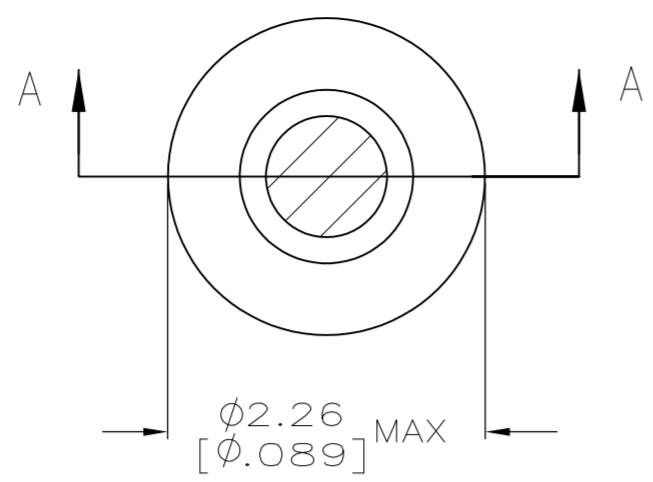

SECTION A-A

- 1. TIN PLATE PER ASTM-B-545 .000254 [.000100] MINIMUM THICK.
- 2. NICKEL UNDERPLATE ALL OVER, MATING SURFACE PLATED TO MEET PERFORMANCE REQUIREMENTS OF TE CONNECTIVITY PRODUCT SPECIFICATION 108-14008.
- 3. RECOMMENDED HOLE SIZE, PLATED OR UNPLATED:
 MACHINE INSERTION: 1.83 ^{+0.10}/_{-0.08} [.072 ^{+0.004}/_{-.003}]
 HAND INSERTION: 1.83 ^{+0.10}/_{-0.00} [.072 ^{+0.004}/_{-.000}]
- 4. APPLICATION TOOL PART NUMBER:
 MACHINE NO. 682127-5
 INSERTION HEAD NO. 682039-4
- 5. TO INSURE PROPER SPRING TENSION DO NOT EXCEED A 0.05 [.002] DIFFERENCE IN PIN DIA WHEN CHANGING TO A SMALLER PIN.
- 6. BOTTOM PLUG KNOCKOUT TOOL PART NUMBER 69729 WITH TIP PART NUMBER 69728-2.
- 7. MATERIAL: SPRING: BERYLLIUM COPPER QQ-C-533
 EYELET: COPPER, QQ-C-576

CLOSED	0.86-1.04 [.034-.041]	TIN $\triangle 1$	TIN $\triangle 1$	5050865-8
KNOCKOUT			GOLD $\triangle 2$	5050865-7
OPEN				5050865-6
CLOSED				5050865-5
OPEN				5050865-3
KNOCKOUT				5050865-1
BOTTOM TYPE	RECOMMENDED PIN DIA $\triangle 5$	EYELET	SPRING	PART NO
		FINISH		

THIS DRAWING IS A CONTROLLED DOCUMENT.		DWN J. ALCORTA - DOCK5 20APR2005	TE Connectivity	
DIMENSIONS: mm [INCHES]		CHK J. HAVENER 25JUL2005	MINIATURE SPRING SOCKET ASSEMBLY SERIES 4	
TOLERANCES UNLESS OTHERWISE SPECIFIED:		APVD J. HAVENER 25JUL2005	NAME	RESTRICTED TO
0 PLC ± -		PRODUCT SPEC	108-14008	
1 PLC ± -		APPLICATION SPEC	114-13152	
2 PLC ± -		WEIGHT	-	
3 PLC ± 0.20 [.008]		SIZE	A2	
4 PLC ± -		CAGE CODE	00779	
ANGLES ± -		DRAWING NO	C=5050865	
FINISH		SCALE	20:1	
SEE TABLE		SHEET	1 of 1	
MATERIAL $\triangle 7$		CUSTOMER DRAWING	REV	A1

5050865

Mouser Electronics

Authorized Distributor

Click to View Pricing, Inventory, Delivery & Lifecycle Information:

[TE Connectivity:](#)

[5050865-5](#)