

N-channel 600 V, 0.097  $\Omega$  typ., 29 A FDmesh™ II Power MOSFET  
(with fast diode) in D<sup>2</sup>PAK, TO-220FP, TO-220 and TO-247

Datasheet — production data

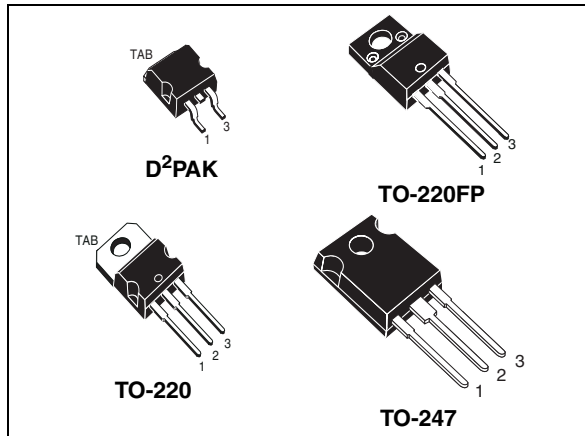
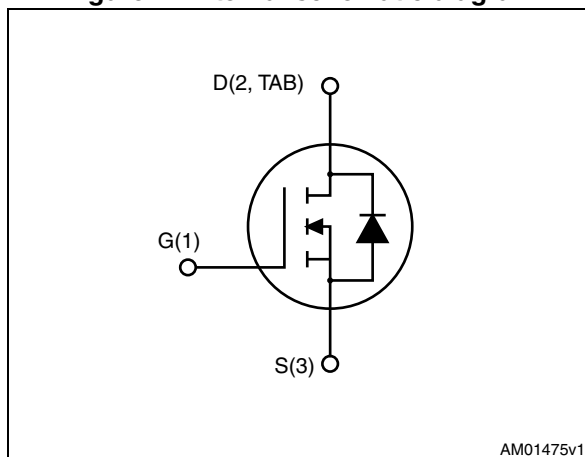

Figure 1. Internal schematic diagram



## Features

Order codes	$V_{DS}$ @ $T_J$ max.	$R_{DS(on)}$ max.	$I_D$
STB34NM60ND	650 V	0.110 $\Omega$	29 A
STF34NM60ND			
STP34NM60ND			
STW34NM60ND			

- The world's best  $R_{DS(on)}$  in TO-220 amongst the fast recovery diode devices
- 100% avalanche tested
- Low input capacitance and gate charge
- Low gate input resistance
- Extremely high dv/dt and avalanche capabilities

## Applications

- Switching applications

## Description

These devices are N-channel FDmesh™ V Power MOSFETs produced using ST's MDmesh™ V technology, which is based on an innovative proprietary vertical structure. The resulting product boasts an extremely low on-resistance that is unrivaled among silicon-based Power MOSFETs, and superior switching performance with intrinsic fast-recovery body diode.

Table 1. Device summary

Order codes	Marking	Packages	Packaging
STB34NM60ND	34NM60ND	D <sup>2</sup> PAK	Tape and reel
STF34NM60ND		TO-220FP	Tube
STP34NM60ND		TO-220	
STW34NM60ND		TO-247	

# Contents

<b>1</b>	<b>Electrical ratings</b> .....	<b>3</b>
<b>2</b>	<b>Electrical characteristics</b> .....	<b>4</b>
2.1	Electrical characteristics (curves) .....	6
<b>3</b>	<b>Test circuits</b> .....	<b>9</b>
<b>4</b>	<b>Package mechanical data</b> .....	<b>10</b>
<b>5</b>	<b>Packaging mechanical data</b> .....	<b>19</b>
<b>6</b>	<b>Revision history</b> .....	<b>21</b>



# 1 Electrical ratings

**Table 2. Absolute maximum ratings**

Symbol	Parameter	Value		Unit
		D <sup>2</sup> PAK, TO-220, TO-247	TO-220FP	
V <sub>DS</sub>	Drain-source voltage	600		V
V <sub>GS</sub>	Gate- source voltage	± 25		V
I <sub>D</sub>	Drain current (continuous) at T <sub>C</sub> = 25 °C	29	29 <sup>(1)</sup>	A
I <sub>D</sub>	Drain current (continuous) at T <sub>C</sub> = 100 °C	18	18 <sup>(1)</sup>	A
I <sub>DM</sub> <sup>(2)</sup>	Drain current (pulsed)	116	116 <sup>(1)</sup>	A
P <sub>TOT</sub>	Total dissipation at T <sub>C</sub> = 25 °C	190	40	W
V <sub>ISO</sub>	Insulation withstand voltage (RMS) from all three leads to external heat sink (t=1 s; T <sub>C</sub> =25 °C)		2500	V
dv/dt <sup>(3)</sup>	Peak diode recovery voltage slope	40		V/ns
T <sub>stg</sub>	Storage temperature	- 55 to 150		°C
T <sub>J</sub>	Max. operating junction temperature	150		

1. Current limited by package
2. Pulse width limited by safe operating area
3.  $I_{SD} \leq 29 \text{ A}$ ,  $di/dt \leq 600 \text{ A}/\mu\text{s}$ ,  $V_{DD} = 80\% V_{(BR)DSS}$ ,  $V_{DSPeak} < V_{(BR)DSS}$

**Table 3. Thermal data**

Symbol	Parameter	TO-220	TO-247	D <sup>2</sup> PAK	TO-220FP	Unit
R <sub>thj-case</sub>	Thermal resistance junction-case max	0.66			3.1	°C/W
R <sub>thj-amb</sub>	Thermal resistance junction-ambient max	62.5	50		62.5	°C/W
R <sub>thj-pcb</sub> <sup>(1)</sup>	Thermal resistance junction-pcb max			30		°C/W

1. When mounted on FR-4 board of 1 inch<sup>2</sup>, 2 oz Cu.

**Table 4. Avalanche characteristics**

Symbol	Parameter	Max value	Unit
I <sub>AR</sub>	Avalanche current, repetitive or not-repetitive (pulse width limited by T <sub>J</sub> max)	7	A
E <sub>AS</sub>	Single pulse avalanche energy (starting T <sub>J</sub> = 25 °C, I <sub>D</sub> = I <sub>AR</sub> , V <sub>DD</sub> = 50 V)	110	mJ

## 2 Electrical characteristics

( $T_{CASE} = 25\text{ °C}$  unless otherwise specified)

**Table 5. On/off states**

Symbol	Parameter	Test conditions	Min.	Typ.	Max.	Unit
$V_{(BR)DSS}$	Drain-source breakdown voltage ( $V_{GS} = 0$ )	$I_D = 1\text{ mA}$	600			V
$I_{DSS}$	Zero gate voltage drain current ( $V_{GS} = 0$ )	$V_{DS} = 600\text{ V}$			1	$\mu\text{A}$
		$V_{DS} = 600\text{ V}, T_C = 125\text{ °C}$			100	$\mu\text{A}$
$I_{GSS}$	Gate-body leakage current ( $V_{DS} = 0$ )	$V_{GS} = \pm 25\text{ V}$			$\pm 100$	nA
$V_{GS(th)}$	Gate threshold voltage	$V_{DS} = V_{GS}, I_D = 250\text{ }\mu\text{A}$	3	4	5	V
$R_{DS(on)}$	Static drain-source on resistance	$V_{GS} = 10\text{ V}, I_D = 14.5\text{ A}$		0.097	0.110	$\Omega$

**Table 6. Dynamic**

Symbol	Parameter	Test conditions	Min.	Typ.	Max.	Unit
$C_{iss}$	Input capacitance		-	2785	-	pF
$C_{oss}$	Output capacitance	$V_{DS} = 50\text{ V}, f = 1\text{ MHz}, V_{GS} = 0$	-	168	-	pF
$C_{rss}$	Reverse transfer capacitance		-	5	-	pF
$C_{oss\text{ eq.}}^{(1)}$	Equivalent output capacitance	$V_{GS} = 0, V_{DS} = 0\text{ to }480\text{ V}$	-	438	-	pF
$t_{d(on)}$	Turn-on delay time	$V_{DD} = 300\text{ V}, I_D = 14.5\text{ A}, R_G = 4.7\text{ }\Omega, V_{GS} = 10\text{ V}$ (see <a href="#">Figure 18</a> and <a href="#">23</a> )	-	30	-	ns
$t_r$	Rise time		-	53.4	-	ns
$t_{d(off)}$	Turn-off delay time		-	111	-	ns
$t_f$	Fall time		-	61.8	-	ns
$Q_g$	Total gate charge		$V_{DD} = 480\text{ V}, I_D = 29\text{ A}, V_{GS} = 10\text{ V},$ (see <a href="#">Figure 19</a> )	-	80.4	-
$Q_{gs}$	Gate-source charge	-		16	-	nC
$Q_{gd}$	Gate-drain charge	-		41.4	-	nC
$R_g$	Gate input resistance	f=1 MHz, open drain	-	2.87	-	$\Omega$

1.  $C_{oss\text{ eq.}}$  is defined as a constant equivalent capacitance giving the same charging time as  $C_{oss}$  when  $V_{DS}$  increases from 0 to 80%  $V_{DSS}$

Table 7. Source drain diode

Symbol	Parameter	Test conditions	Min.	Typ.	Max.	Unit
$I_{SD}$	Source-drain current		-		29	A
$I_{SDM}^{(1)}$	Source-drain current (pulsed)		-		116	A
$V_{SD}^{(2)}$	Forward on voltage	$I_{SD} = 29\text{ A}, V_{GS} = 0$	-		1.6	V
$t_{rr}$	Reverse recovery time	$I_{SD} = 29\text{ A}, V_{DD} = 60\text{ V}$ $di/dt = 100\text{ A}/\mu\text{s}$ (see <a href="#">Figure 20</a> )	-	175		ns
$Q_{rr}$	Reverse recovery charge		-	1.4		$\mu\text{C}$
$I_{RRM}$	Reverse recovery current		-	16		A
$t_{rr}$	Reverse recovery time	$I_{SD} = 29\text{ A}, V_{DD} = 60\text{ V}$ $di/dt = 100\text{ A}/\mu\text{s}$ , $T_J = 150\text{ }^\circ\text{C}$ (see <a href="#">Figure 20</a> )	-	255		ns
$Q_{rr}$	Reverse recovery charge		-	2.6		$\mu\text{C}$
$I_{RRM}$	Reverse recovery current		-	20		A

1. Pulse width limited by safe operating area
2. Pulsed: Pulse duration = 300  $\mu\text{s}$ , duty cycle 1.5%.

## 2.1 Electrical characteristics (curves)

Figure 2. Safe operating area for TO-220FP

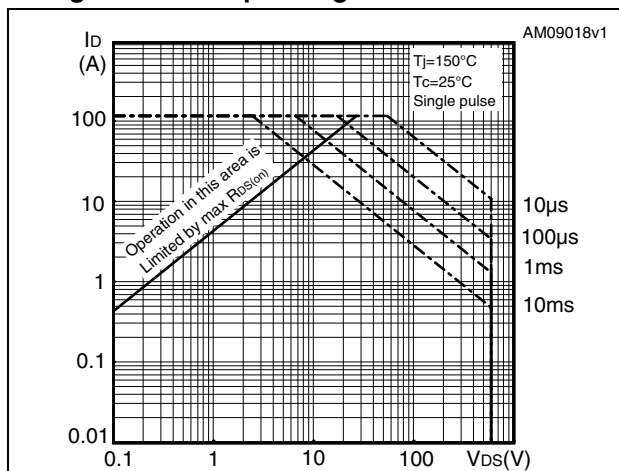

Figure 3. Thermal impedance for TO-220FP

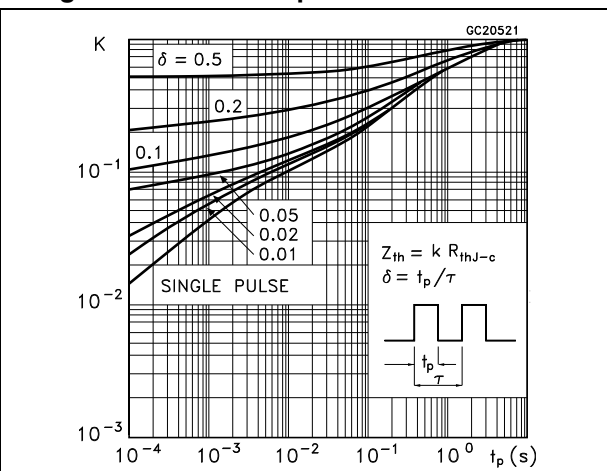

Figure 4. Safe operating area for TO-220 and D<sup>2</sup>PAK

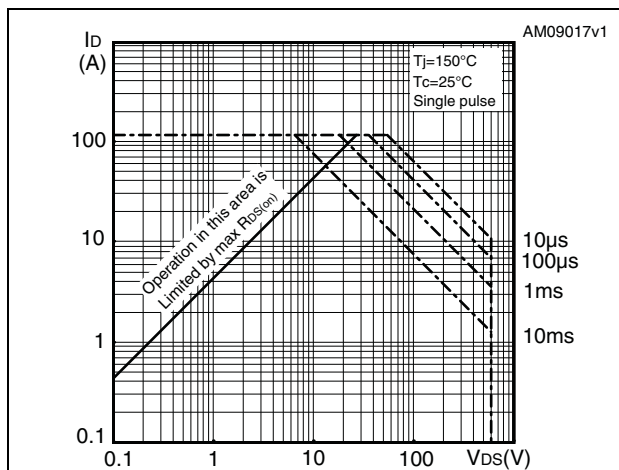

Figure 5. Thermal impedance for TO-220 and D<sup>2</sup>PAK

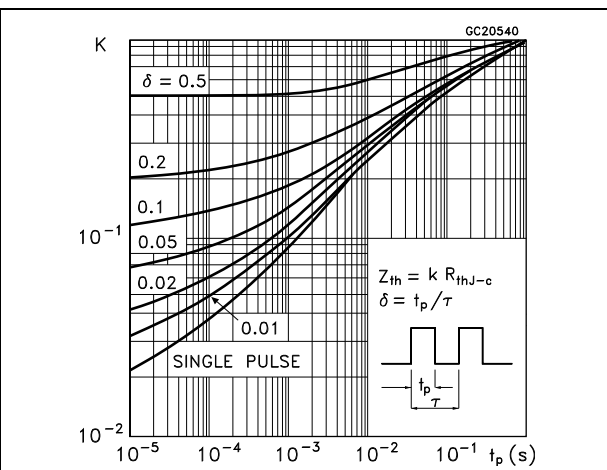

Figure 6. Safe operating area for TO-247

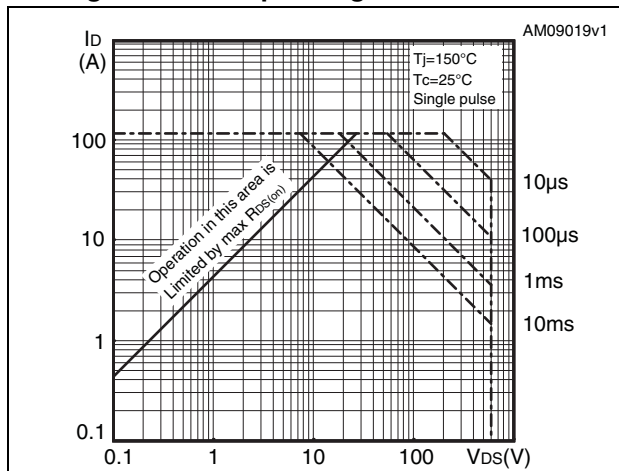

Figure 7. Thermal impedance for TO-247

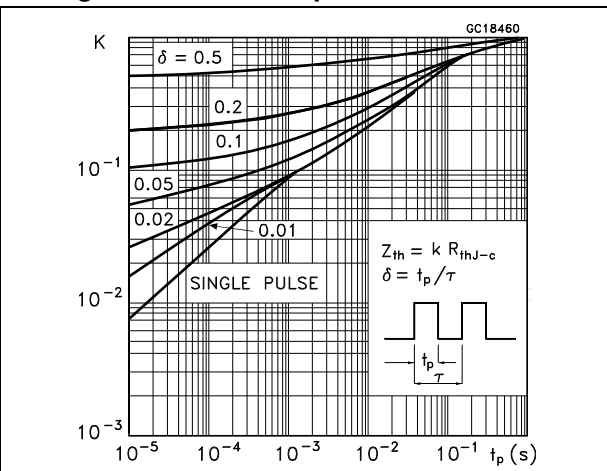

Figure 8. Output characteristics

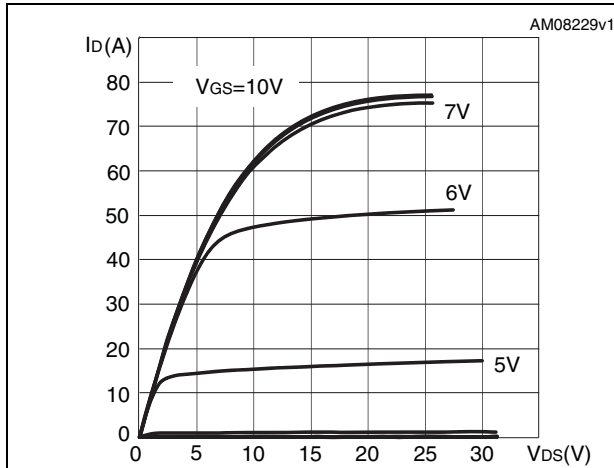

Figure 9. Transfer characteristics

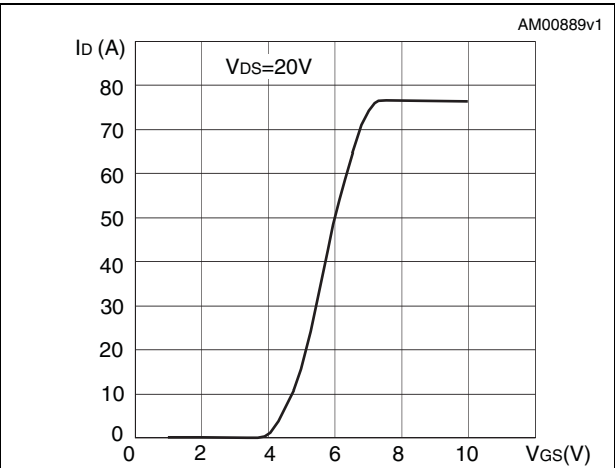

Figure 10. Gate charge vs gate-source voltage

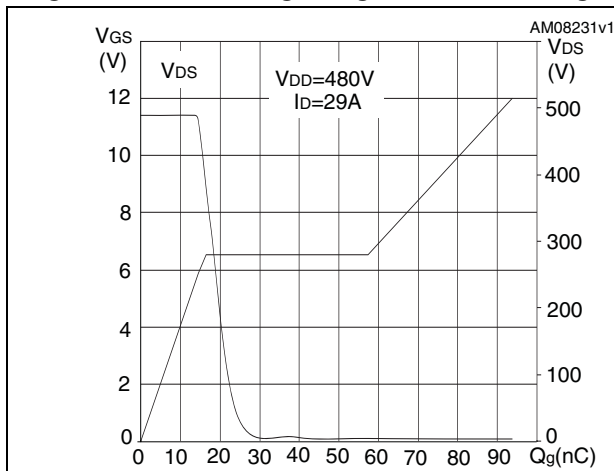

Figure 11. Static drain-source on-resistance

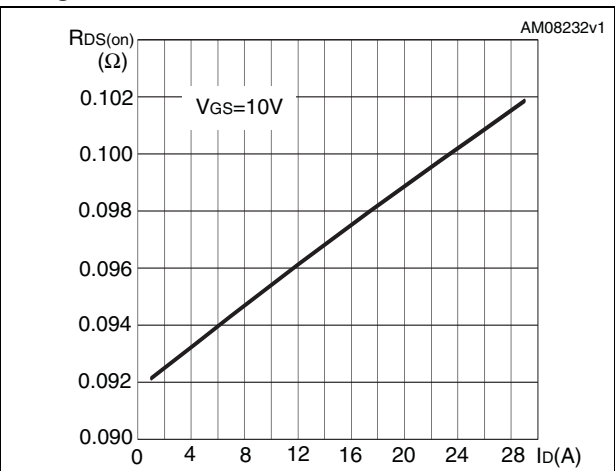

Figure 12. Capacitance variations

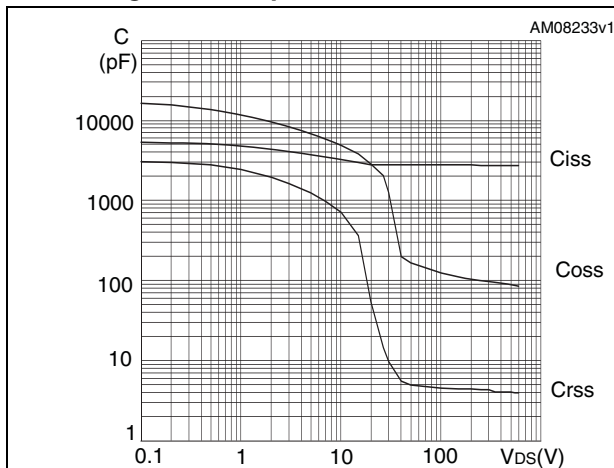

Figure 13. Output capacitance stored energy

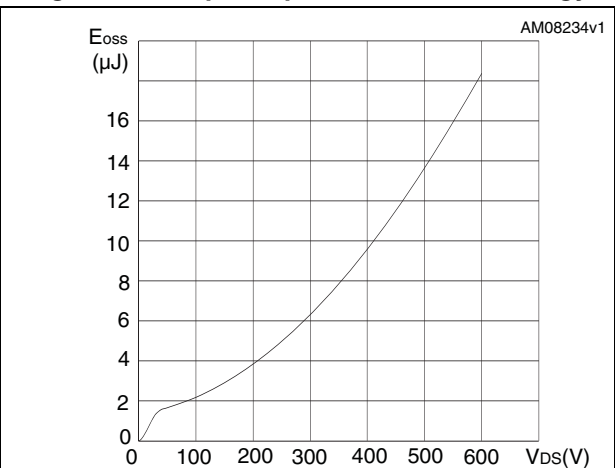

Figure 14. Normalized gate threshold voltage vs temperature

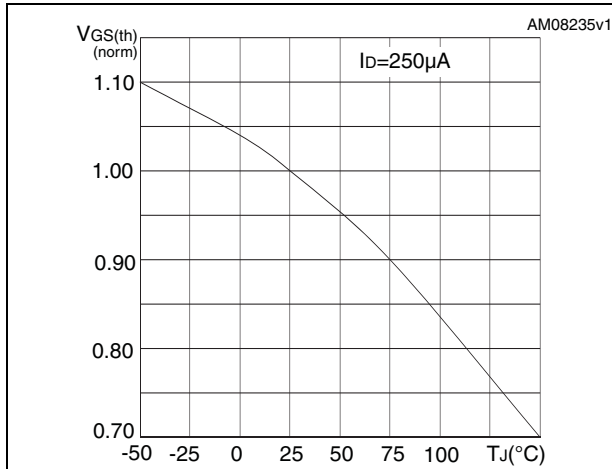

Figure 15. Normalized on-resistance vs temperature

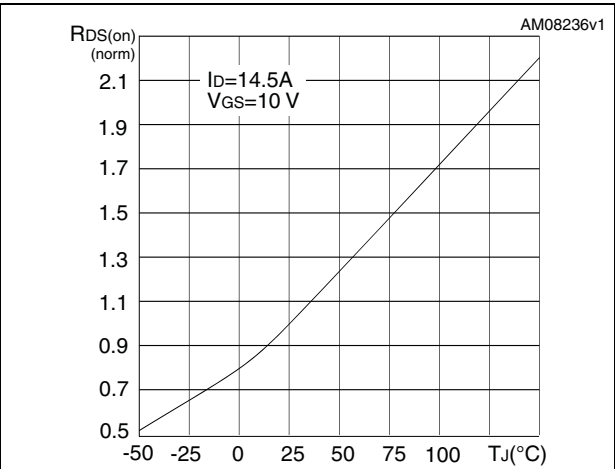

Figure 16. Normalized V<sub>DS</sub> vs temperature

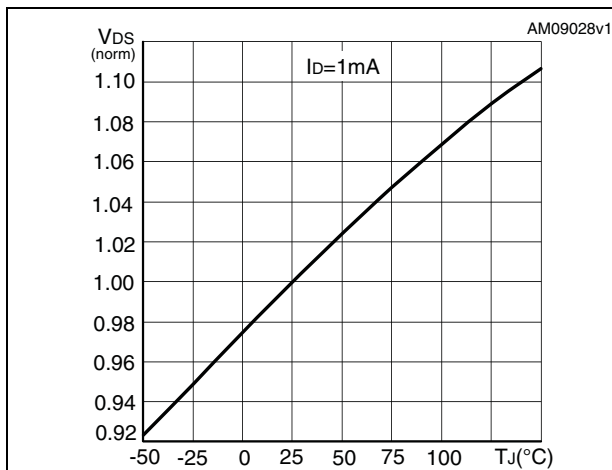
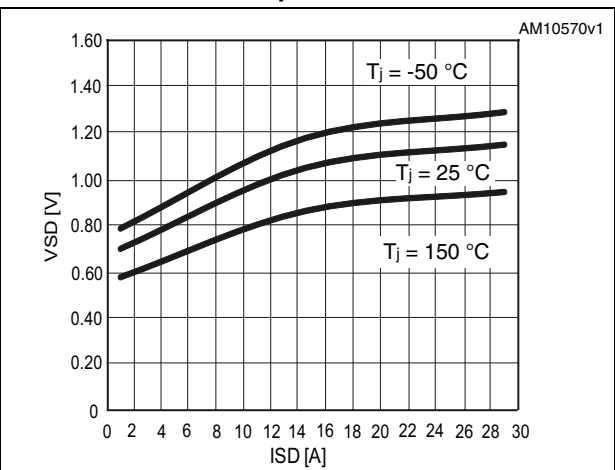

Figure 17. Source-drain diode forward vs temperature





### 3 Test circuits

Figure 18. Switching times test circuit for resistive load



Figure 19. Gate charge test circuit

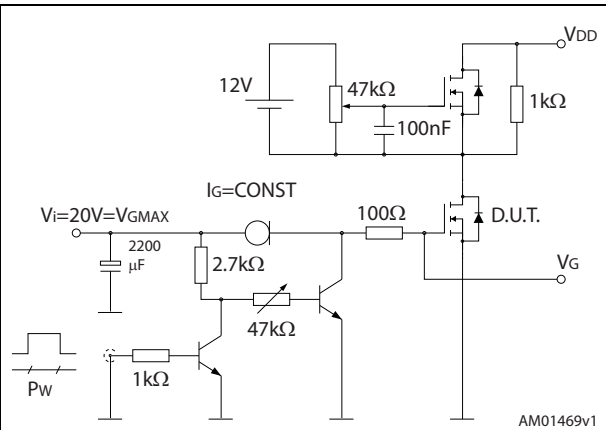

Figure 20. Test circuit for inductive load switching and diode recovery times

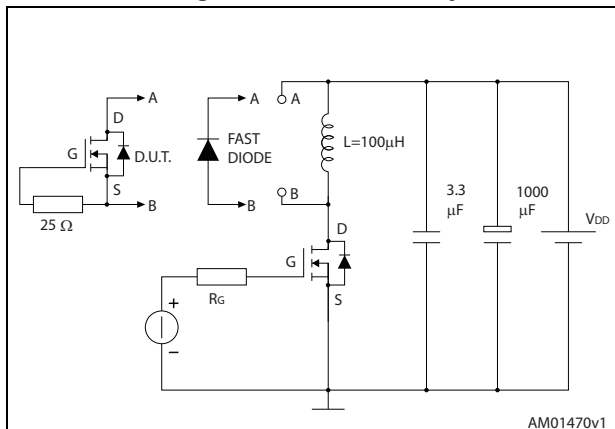

Figure 21. Unclamped inductive load test circuit

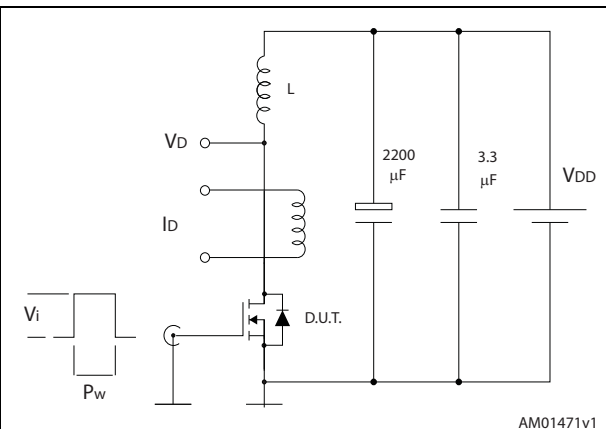

Figure 22. Unclamped inductive waveform

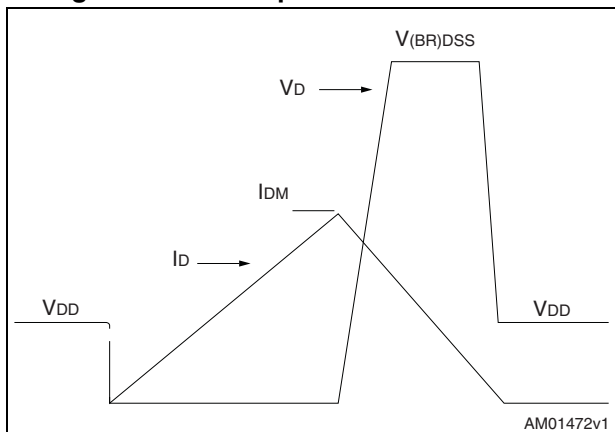
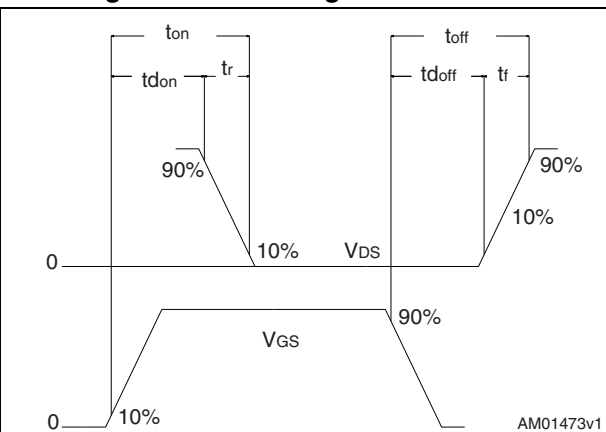

Figure 23. Switching time waveform



## 4 Package mechanical data

In order to meet environmental requirements, ST offers these devices in different grades of ECOPACK<sup>®</sup> packages, depending on their level of environmental compliance. ECOPACK<sup>®</sup> specifications, grade definitions and product status are available at: [www.st.com](http://www.st.com). ECOPACK<sup>®</sup> is an ST trademark.

Table 8. D<sup>2</sup>PAK (TO-263) mechanical data

Dim.	mm		
	Min.	Typ.	Max.
A	4.40		4.60
A1	0.03		0.23
b	0.70		0.93
b2	1.14		1.70
c	0.45		0.60
c2	1.23		1.36
D	8.95		9.35
D1	7.50		
E	10		10.40
E1	8.50		
e		2.54	
e1	4.88		5.28
H	15		15.85
J1	2.49		2.69
L	2.29		2.79
L1	1.27		1.40
L2	1.30		1.75
R		0.4	
V2	0°		8°

Figure 24. D<sup>2</sup>PAK (TO-263) drawing

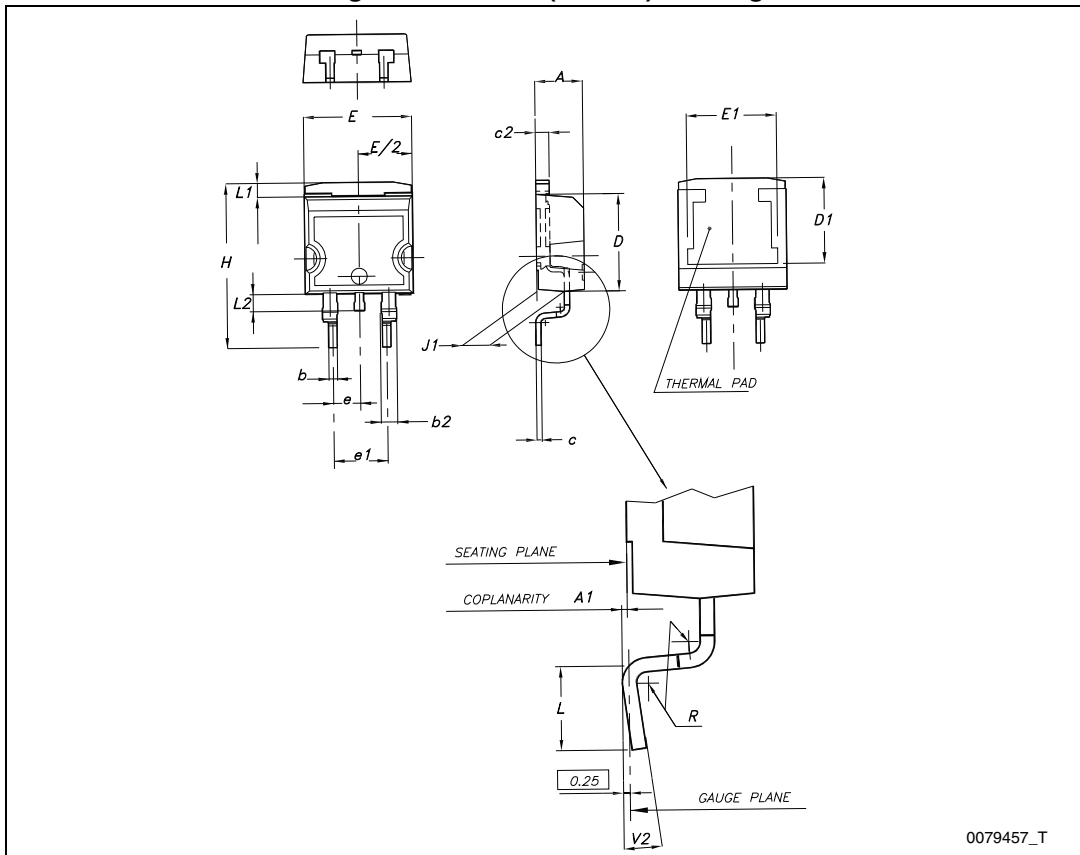
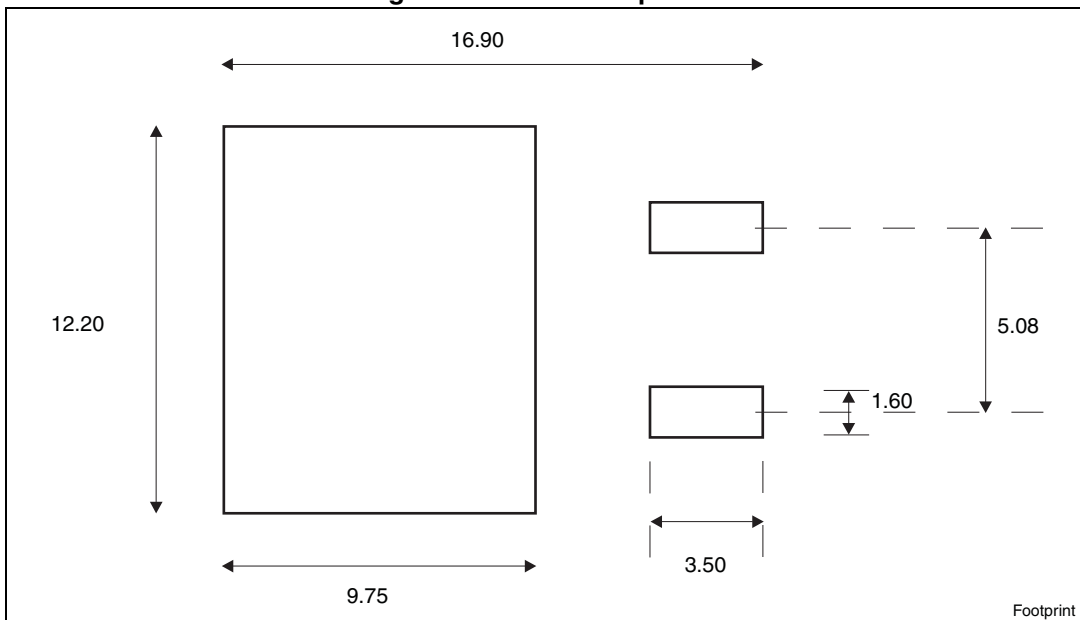

Figure 25. D<sup>2</sup>PAK footprint<sup>(a)</sup>



a. All dimension are in millimeters

Table 9. TO-220FP mechanical data

Dim.	mm		
	Min.	Typ.	Max.
A	4.4		4.6
B	2.5		2.7
D	2.5		2.75
E	0.45		0.7
F	0.75		1
F1	1.15		1.70
F2	1.15		1.70
G	4.95		5.2
G1	2.4		2.7
H	10		10.4
L2		16	
L3	28.6		30.6
L4	9.8		10.6
L5	2.9		3.6
L6	15.9		16.4
L7	9		9.3
Dia	3		3.2

Figure 26. TO-220FP drawing

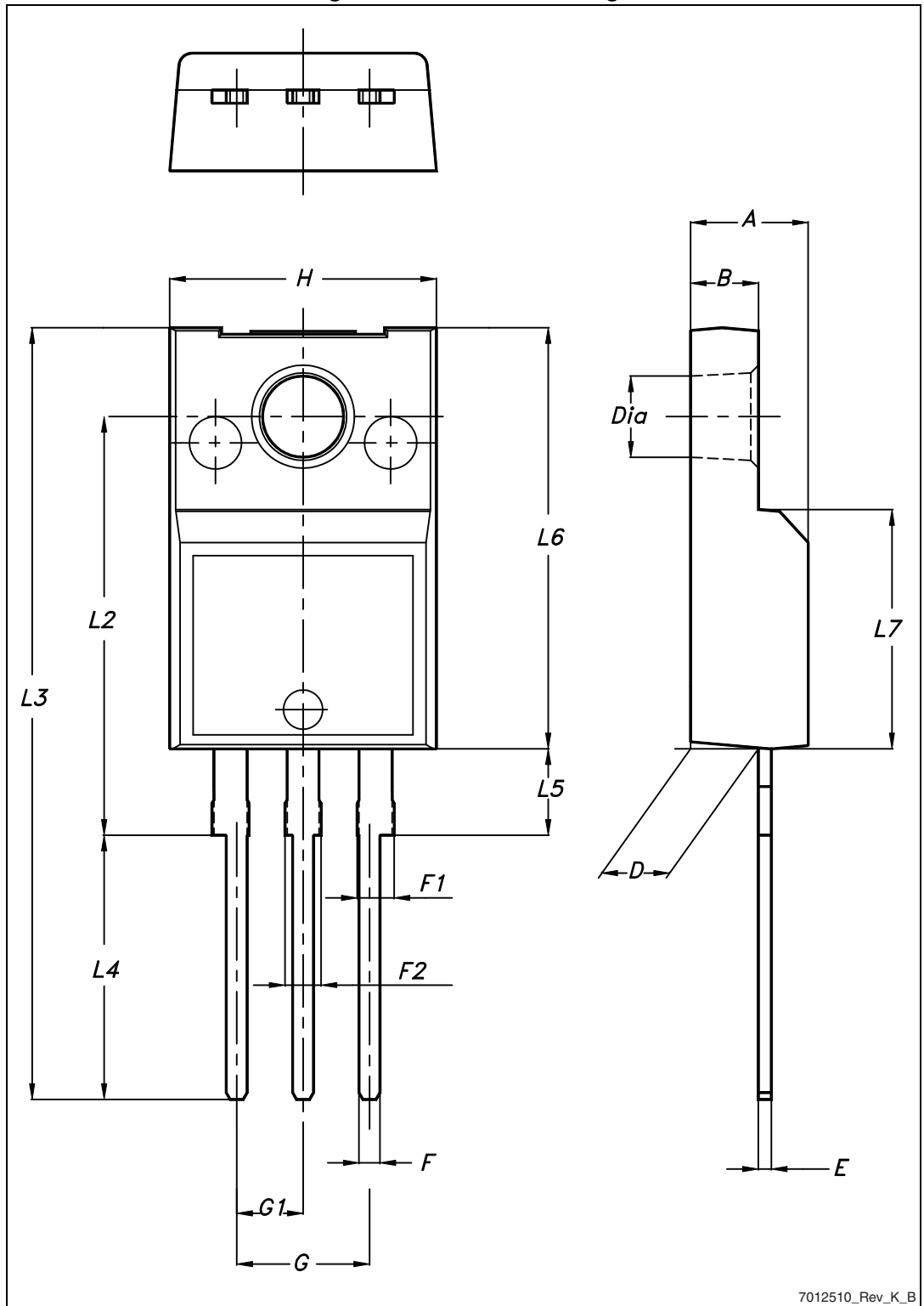

7012510\_Rev\_K\_B

Table 10. TO-220 type A mechanical data

Dim.	mm		
	Min.	Typ.	Max.
A	4.40		4.60
b	0.61		0.88
b1	1.14		1.70
c	0.48		0.70
D	15.25		15.75
D1		1.27	
E	10		10.40
e	2.40		2.70
e1	4.95		5.15
F	1.23		1.32
H1	6.20		6.60
J1	2.40		2.72
L	13		14
L1	3.50		3.93
L20		16.40	
L30		28.90	
ØP	3.75		3.85
Q	2.65		2.95

Figure 27. TO-220 type A drawing

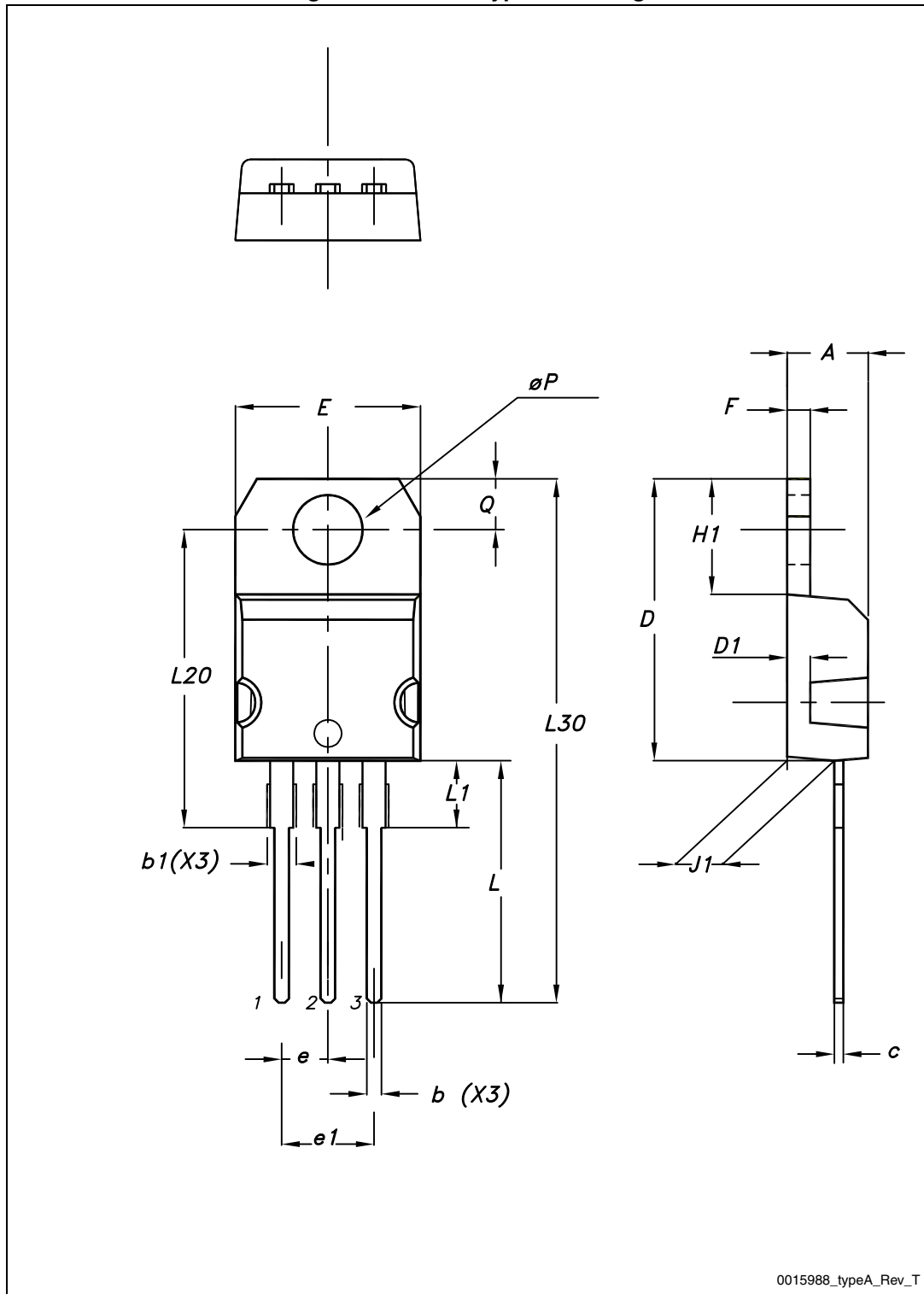
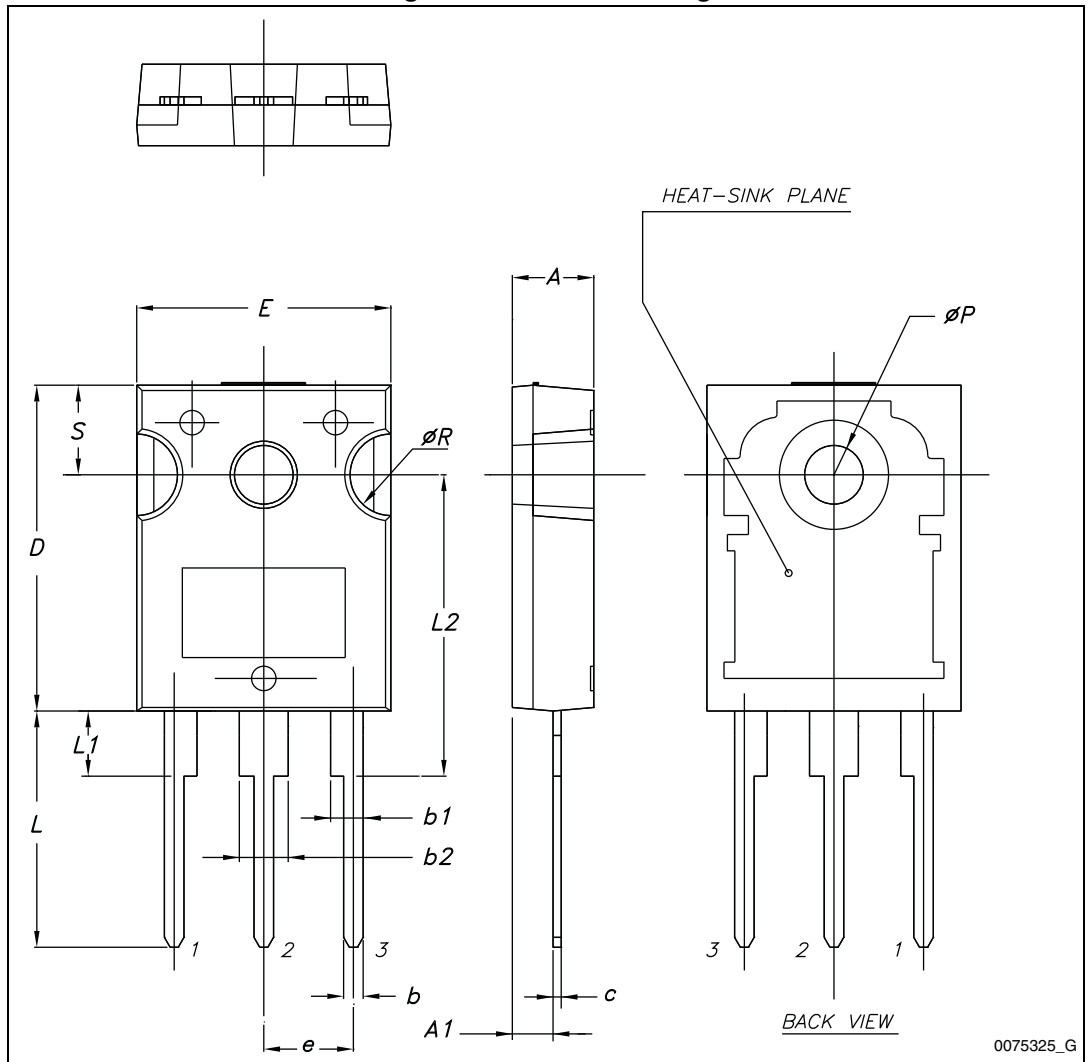



Table 11. TO-247 mechanical data

Dim.	mm.		
	Min.	Typ.	Max.
A	4.85		5.15
A1	2.20		2.60
b	1.0		1.40
b1	2.0		2.40
b2	3.0		3.40
c	0.40		0.80
D	19.85		20.15
E	15.45		15.75
e	5.30	5.45	5.60
L	14.20		14.80
L1	3.70		4.30
L2		18.50	
ØP	3.55		3.65
ØR	4.50		5.50
S	5.30	5.50	5.70

Figure 28. TO-247 drawing



## 5 Packaging mechanical data

Table 12. D<sup>2</sup>PAK (TO-263) tape and reel mechanical data

Tape			Reel		
Dim.	mm		Dim.	mm	
	Min.	Max.		Min.	Max.
A0	10.5	10.7	A		330
B0	15.7	15.9	B	1.5	
D	1.5	1.6	C	12.8	13.2
D1	1.59	1.61	D	20.2	
E	1.65	1.85	G	24.4	26.4
F	11.4	11.6	N	100	
K0	4.8	5.0	T		30.4
P0	3.9	4.1			
P1	11.9	12.1		Base qty	1000
P2	1.9	2.1		Bulk qty	1000
R	50				
T	0.25	0.35			
W	23.7	24.3			

Figure 29. Tape

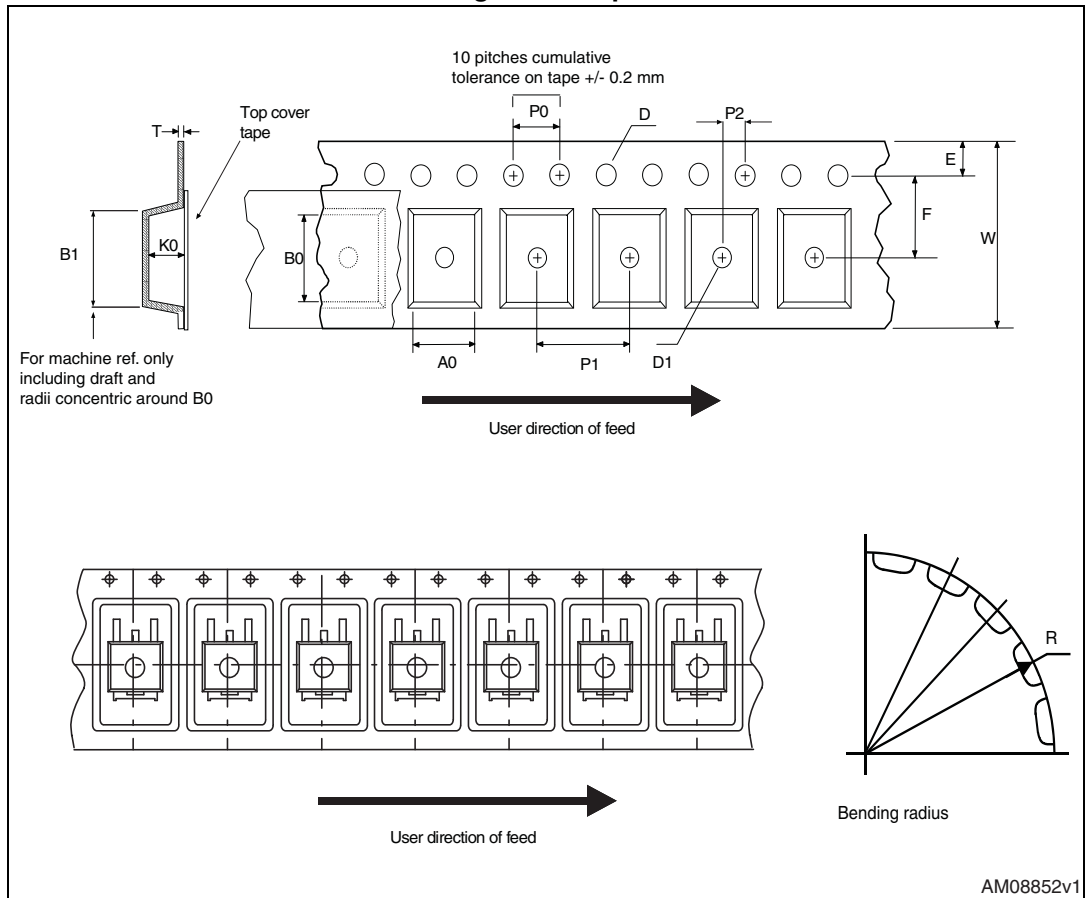
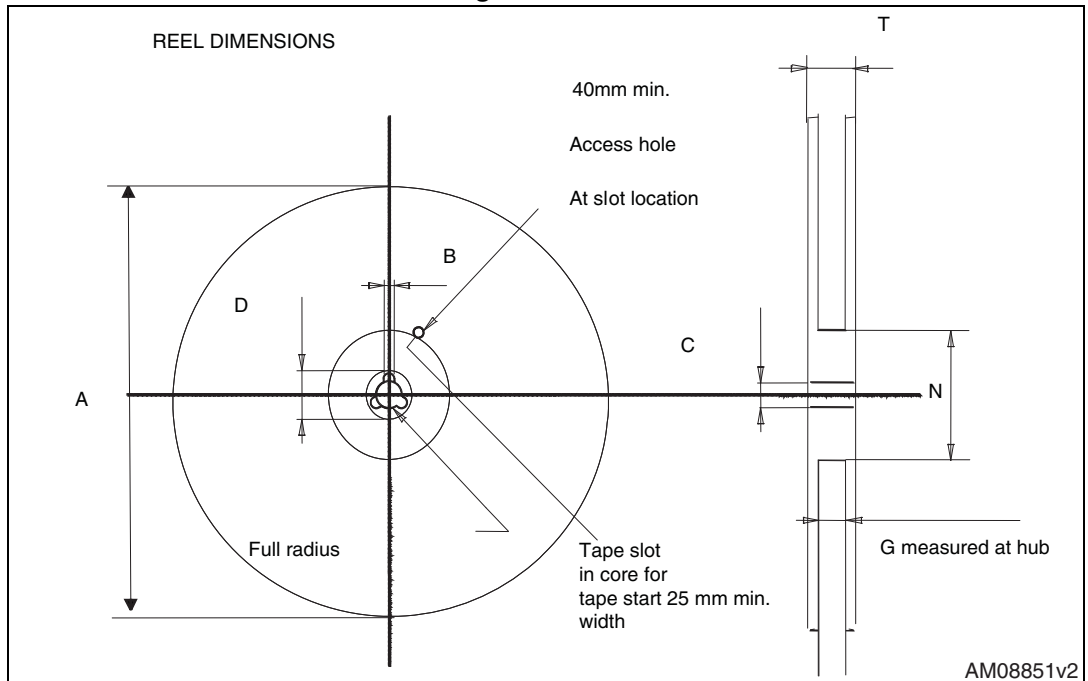

Figure 30. Reel



## 6 Revision history

**Table 13. Document revision history**

Date	Revision	Changes
04-Nov-2010	1	Initial release.
18-Apr-2011	2	Corrected E <sub>AS</sub> value in <a href="#">Table 4: Avalanche characteristics</a>
14-Sep-2011	3	Added order code in D <sup>2</sup> PAK and TO-220FP Updated <a href="#">Table 1: Device summary</a> , <a href="#">Table 2: Absolute maximum ratings</a> and <a href="#">Table 3: Thermal data</a> . Updated <a href="#">Section 4: Package mechanical data</a> . Added <a href="#">Section 5: Packaging mechanical data</a> . Minor text changes.
29-Dec-2011	4	Updated description in cover page.
01-Oct-2012	5	Updated title on the cover page. Updated figures <a href="#">10</a> , <a href="#">11</a> , <a href="#">16</a> and <a href="#">17</a> . Updated <a href="#">Section 4: Package mechanical data</a> . Minor text changes.
02-Oct-2013	6	– Modified: E <sub>AS</sub> in <a href="#">Table 4</a> , C <sub>oss eq.</sub> typical value in <a href="#">Table 6</a> , <a href="#">Figure 13</a> – Modified: <a href="#">Figure 18</a> , <a href="#">19</a> , <a href="#">20</a> and <a href="#">21</a> – Minor text changes

**Please Read Carefully:**

Information in this document is provided solely in connection with ST products. STMicroelectronics NV and its subsidiaries ("ST") reserve the right to make changes, corrections, modifications or improvements, to this document, and the products and services described herein at any time, without notice.

All ST products are sold pursuant to ST's terms and conditions of sale.

Purchasers are solely responsible for the choice, selection and use of the ST products and services described herein, and ST assumes no liability whatsoever relating to the choice, selection or use of the ST products and services described herein.

No license, express or implied, by estoppel or otherwise, to any intellectual property rights is granted under this document. If any part of this document refers to any third party products or services it shall not be deemed a license grant by ST for the use of such third party products or services, or any intellectual property contained therein or considered as a warranty covering the use in any manner whatsoever of such third party products or services or any intellectual property contained therein.

**UNLESS OTHERWISE SET FORTH IN ST'S TERMS AND CONDITIONS OF SALE ST DISCLAIMS ANY EXPRESS OR IMPLIED WARRANTY WITH RESPECT TO THE USE AND/OR SALE OF ST PRODUCTS INCLUDING WITHOUT LIMITATION IMPLIED WARRANTIES OF MERCHANTABILITY, FITNESS FOR A PARTICULAR PURPOSE (AND THEIR EQUIVALENTS UNDER THE LAWS OF ANY JURISDICTION), OR INFRINGEMENT OF ANY PATENT, COPYRIGHT OR OTHER INTELLECTUAL PROPERTY RIGHT.**

**ST PRODUCTS ARE NOT DESIGNED OR AUTHORIZED FOR USE IN: (A) SAFETY CRITICAL APPLICATIONS SUCH AS LIFE SUPPORTING, ACTIVE IMPLANTED DEVICES OR SYSTEMS WITH PRODUCT FUNCTIONAL SAFETY REQUIREMENTS; (B) AERONAUTIC APPLICATIONS; (C) AUTOMOTIVE APPLICATIONS OR ENVIRONMENTS, AND/OR (D) AEROSPACE APPLICATIONS OR ENVIRONMENTS. WHERE ST PRODUCTS ARE NOT DESIGNED FOR SUCH USE, THE PURCHASER SHALL USE PRODUCTS AT PURCHASER'S SOLE RISK, EVEN IF ST HAS BEEN INFORMED IN WRITING OF SUCH USAGE, UNLESS A PRODUCT IS EXPRESSLY DESIGNATED BY ST AS BEING INTENDED FOR "AUTOMOTIVE, AUTOMOTIVE SAFETY OR MEDICAL" INDUSTRY DOMAINS ACCORDING TO ST PRODUCT DESIGN SPECIFICATIONS. PRODUCTS FORMALLY ESCC, QML OR JAN QUALIFIED ARE DEEMED SUITABLE FOR USE IN AEROSPACE BY THE CORRESPONDING GOVERNMENTAL AGENCY.**

Resale of ST products with provisions different from the statements and/or technical features set forth in this document shall immediately void any warranty granted by ST for the ST product or service described herein and shall not create or extend in any manner whatsoever, any liability of ST.

ST and the ST logo are trademarks or registered trademarks of ST in various countries.

Information in this document supersedes and replaces all information previously supplied.

The ST logo is a registered trademark of STMicroelectronics. All other names are the property of their respective owners.

© 2013 STMicroelectronics - All rights reserved

STMicroelectronics group of companies

Australia - Belgium - Brazil - Canada - China - Czech Republic - Finland - France - Germany - Hong Kong - India - Israel - Italy - Japan - Malaysia - Malta - Morocco - Philippines - Singapore - Spain - Sweden - Switzerland - United Kingdom - United States of America

[www.st.com](http://www.st.com)

# Mouser Electronics

Authorized Distributor

Click to View Pricing, Inventory, Delivery & Lifecycle Information:

[STMicroelectronics:](#)

[STB34NM60ND](#) [STF34NM60ND](#) [STP34NM60ND](#) [STW34NM60ND](#)