

REVISIONS			
REV	DESCRIPTION	DATE	APPROVED
B1	REVISED PER ECO-11-005030	11MAR11	HMR

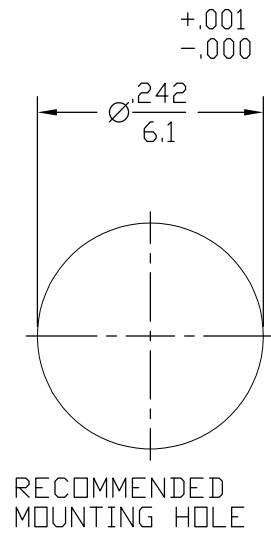
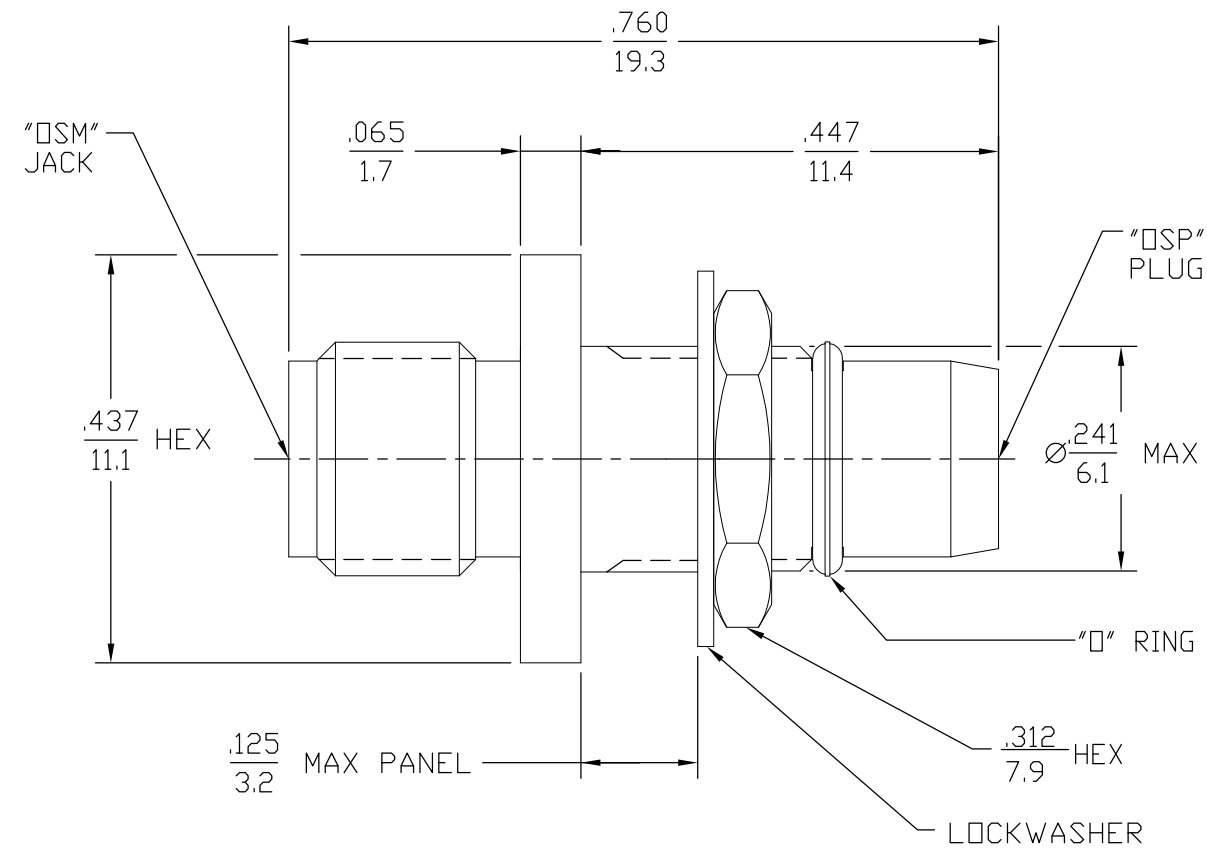

COMPONENT	MATERIAL	FINISH
HOUSING MOUNTING NUT LOCKWASHER	STAINLESS STEEL PER ASTM-A484 AND ASTM- A582, TYPE 303	PASSIVATE PER QQ-P-35
DIELECTRIC	TFE FLUOROCARBON PER ASTM-D-1457	N/A
CENTER CONTACT	BERYLLIUM COPPER PER ASTM-B-196 OR ASTM-B-197, ALLOY C17300, CONDITION H	GOLD PLATE PER MIL-G-45204
O-RING	FLOUROSILICONE PER MIL-R- 25988, CLASS I, TYPE I.	N/A

NOTE:

- CAPTURED CENTER CONTACT

.XXX = in
XX.X = mm (REF)

UNLESS OTHERWISE SPECIFIED DIMENSIONS ARE IN INCHES	DRAWN BY K.I.E.	DATE 9-10-96
	CHECKED BY	
	APP'D BY <i>D. Comello</i>	9/10/96



USE ASS'Y PROCEDURE	TITLE OSM JACK TO OSP BULKHEAD FEEDTHROUGH PLUG ADAPTER		
ND. A.P. _____	SIZE B	CODE IDENT NO. 26805	1059756-1
CUSTOMER DRAWING	SCALE 5:1	N/A	SHEET 1 OF 1

REV
B1

Mouser Electronics

Authorized Distributor

Click to View Pricing, Inventory, Delivery & Lifecycle Information:

[TE Connectivity:](#)

[4585-2240-02](#)