

# TJA1027

LIN 2.2A/SAE J2602 transceiver

Rev. 2 — 24 April 2013

Product data sheet

## 1. General description

---

The TJA1027 is the interface between the Local Interconnect Network (LIN) master/slave protocol controller and the physical bus in a LIN network. It is primarily intended for in-vehicle sub-networks using baud rates up to 20 kBd and is compliant with LIN 2.0, LIN 2.1, LIN 2.2, LIN 2.2A and SAE J2602. The TJA1027 is pin-compatible with the TJA1020 and the TJA1021.

The transmit data stream generated by the protocol controller is converted by the TJA1027 into an optimized bus signal shaped to minimize ElectroMagnetic Emissions (EME). The LIN bus output pin is pulled HIGH via an internal termination resistor. For a master application, an external resistor in series with a diode should be connected between pin V<sub>BAT</sub> and pin LIN. The receiver detects a receive data stream on the LIN bus input pin and transfers it via pin RXD to the microcontroller.

Power consumption is very low in Sleep mode. However, the TJA1027 can still be woken up via pins LIN and SLP\_N.

## 2. Features and benefits

---

### 2.1 General

- Compliant with LIN 2.0, LIN 2.1, LIN 2.2, LIN 2.2A and SAE J2602
- Baud rate up to 20 kBd
- Very low ElectroMagnetic Emissions (EME)
- Very low current consumption in Sleep mode with remote LIN wake-up
- Input levels compatible with 3.3 V and 5 V devices
- Integrated termination resistor for LIN slave applications
- Passive behavior in unpowered state
- Operational during cranking pulse: full operation from 5 V upwards
- Undervoltage detection
- K-line compatible
- Available in SO8 and HVSON8 packages
- Leadless HVSON8 package (3.0 mm × 3.0 mm) with improved Automated Optical Inspection (AOI) capability
- Dark green product (halogen free and Restriction of Hazardous Substances (RoHS) compliant)
- Pin-compatible subset of the TJA1020 and TJA1021



## 2.2 Protection

- Very high ElectroMagnetic Immunity (EMI)
- Very high ESD robustness:  $\pm 8$  kV according to IEC 61000-4-2 for pins LIN and  $V_{BAT}$
- Bus terminal and battery pin protected against transients in the automotive environment (ISO 7637)
- Bus terminal short-circuit proof to battery and ground
- Thermally protected
- Initial transmit data (TXD) dominant check

## 3. Quick reference data

Table 1. Quick reference data

Symbol	Parameter	Conditions	Min	Typ	Max	Unit
$V_{BAT}$	battery supply voltage	limiting values	-0.3	-	+42	V
		operating range	5	-	18	V
$I_{BAT}$	battery supply current	Sleep mode; $V_{LIN} = V_{BAT}$ ; $V_{SLP\_N} = 0$ V	2.5	7	10	$\mu$ A
		Standby mode; $V_{LIN} = V_{BAT}$ ; $V_{SLP\_N} = 0$ V	2.5	7	10	$\mu$ A
		Normal mode; $V_{LIN} = V_{BAT}$ ; $V_{SLP\_N} = 5$ V; $V_{TXD} = 5$ V	200	800	1600	$\mu$ A
$V_{LIN}$	voltage on pin LIN	limiting value; with respect to GND and $V_{BAT}$	-42	-	+42	V
$V_{ESD}$	electrostatic discharge voltage	on pin LIN; according to IEC 61000-4-2	-8	-	+8	kV
$T_{vj}$	virtual junction temperature		-40	-	+150	$^{\circ}$ C

## 4. Ordering information

Table 2. Ordering information

Type number	Package		Version
	Name	Description	
TJA1027T/20	SO8	plastic small outline package; 8 leads; body width 3.9 mm	SOT96-1
TJA1027TK/20	HVSON8	plastic thermal enhanced very thin small outline package; no leads; 8 terminals; body $3 \times 3 \times 0.85$ mm	SOT782-1

5. Block diagram

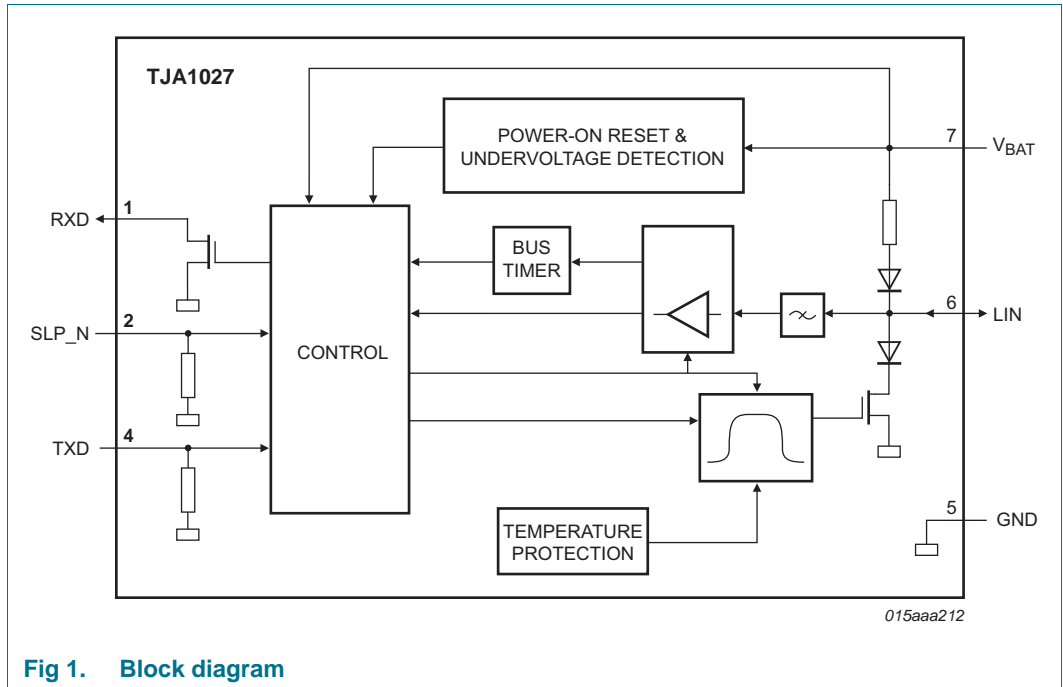

Fig 1. Block diagram

## 6. Pinning information

### 6.1 Pinning

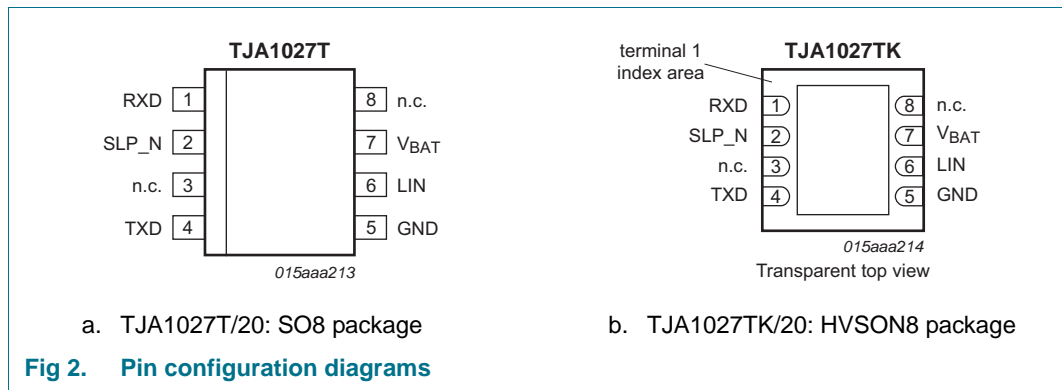

Fig 2. Pin configuration diagrams

### 6.2 Pin description

Table 3. Pin description

Symbol	Pin	Description
RXD	1	receive data output (open-drain); active LOW after a wake-up event
SLP_N	2	sleep control input (active LOW); resets wake-up request on RXD
n.c.	3	not connected
TXD	4	transmit data input
GND	5 <sup>[1]</sup>	ground
LIN	6	LIN bus line input/output
V <sub>BAT</sub>	7	battery supply
n.c.	8	not connected

[1] For enhanced thermal and electrical performance, the exposed center pad of the HVSON8 package should be soldered to board ground (and not to any other voltage level).

## 7. Functional description

---

The TJA1027 is the interface between the LIN master/slave protocol controller and the physical bus in a LIN network. According to the Open System Interconnect (OSI) model, this is the LIN physical layer.

The LIN transceiver is optimized for, but not limited to, automotive applications with excellent ElectroMagnetic Compatibility (EMC) performance.

### 7.1 LIN 2.x/SAE J2602 compliant

The TJA1027 is fully LIN 2.0, LIN 2.1, LIN 2.2, LIN 2.2A and SAE J2602 compliant. The LIN physical layer is independent of higher OSI model layers (e.g. the LIN protocol). Consequently, nodes containing a LIN 2.2A-compliant physical layer can be combined, without restriction, with LIN physical layer nodes that comply with earlier revisions (LIN 1.0, LIN 1.1, LIN 1.2, LIN 1.3, LIN 2.0, LIN 2.1 and LIN 2.2).

### 7.2 Operating modes

The TJA1027 supports modes for normal operation (Normal mode) and very-low-power operation (Sleep mode). An intermediate wake-up mode between Sleep and Normal modes is also supported (Standby mode). The state diagram is shown in [Figure 3](#).

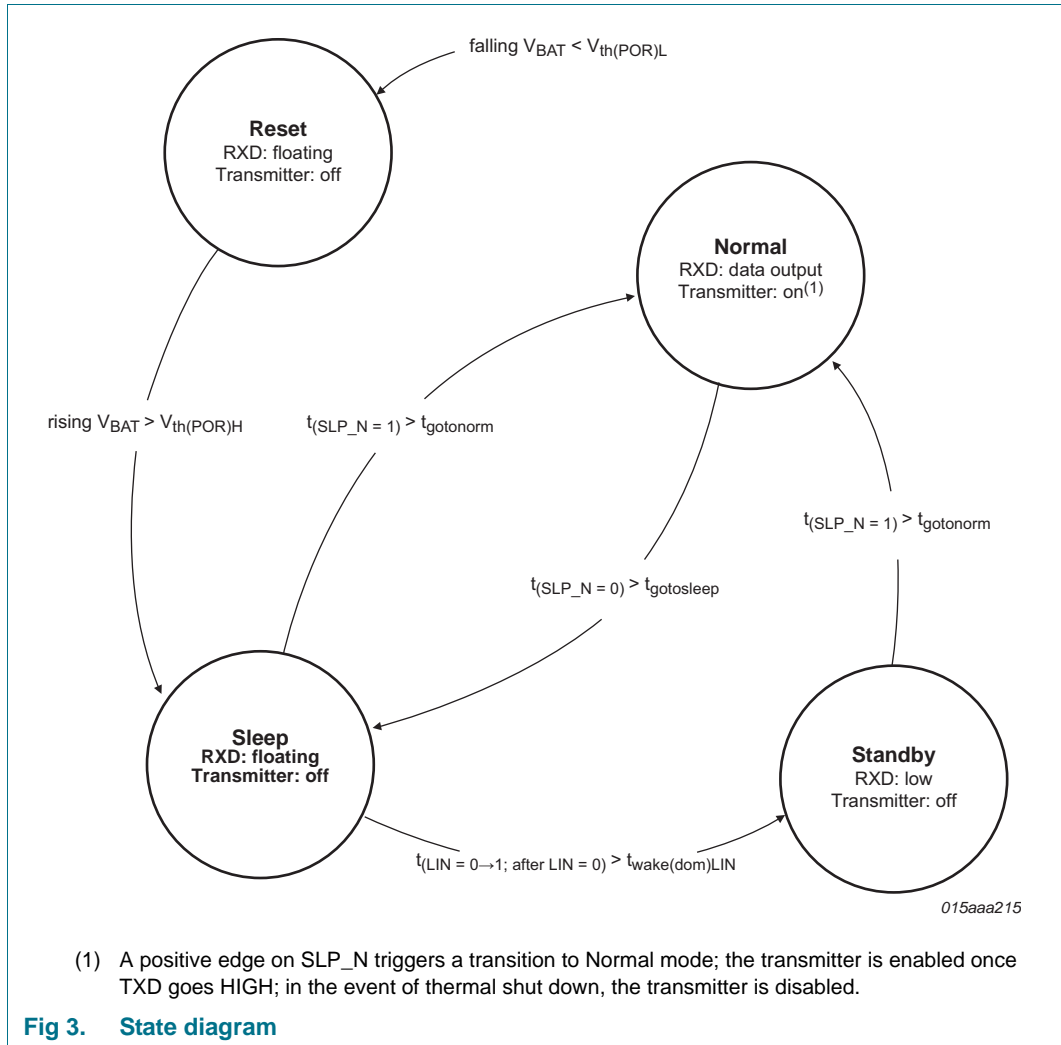

Fig 3. State diagram

Table 4. Operating modes

Mode	SLP_N	RXD	Transmitter	Description
Reset	x	floating	off	all inputs ignored; all outputs drivers off
Sleep <sup>[1]</sup>	0	floating	off	no wake-up request detected
Standby <sup>[2]</sup>	0	LOW <sup>[3]</sup>	off	wake-up request detected
Normal	1	HIGH: recessive state LOW: dominant state	Normal mode <sup>[4]</sup>	bus signal shaping enabled

[1] The TJA1027 enters Sleep mode after a power-on reset (e.g. after switching on  $V_{BAT}$ ).

[2] The TJA1027 will switch automatically to Standby mode if a LIN wake-up event occurs during Sleep mode.

[3] The wake-up interrupt (on pin RXD) is released after a positive edge on pin SLP\_N.

[4] A positive edge on SLP\_N will trigger a transition to Normal mode. The transmitter will be off if TXD is LOW and will be enabled as soon as TXD goes HIGH.

### 7.2.1 Reset mode

When the TJA1027 is in Reset mode, it ignores all input signals and all output drivers are off. The TJA1027 switches to Reset mode when the voltage on  $V_{BAT}$  drops below the LOW-level power-on reset threshold,  $V_{th(POR)L}$ . When the voltage on  $V_{BAT}$  rises above the HIGH-level power-on reset threshold,  $V_{th(POR)H}$ , the TJA1027 switches to Sleep mode.

### 7.2.2 Sleep mode

The TJA1027 consumes significantly less power in Sleep mode than in any other mode. Even though current consumption is extremely low in Sleep mode, the TJA1027 can still be woken up remotely via pin LIN or activated directly via pin SLP\_N. Filters on the receiver input (LIN) and on pin SLP\_N prevent unwanted wake-up events occurring due to automotive transients or radio frequency interference. All wake-up events must be maintained for a specific period of time ( $t_{wake(dom)LIN}$  or  $t_{gotonorm}$ ).

Sleep mode is initiated by a falling edge on pin SLP\_N in Normal mode. The LIN transmit path is immediately disabled when pin SLP\_N goes LOW. In order to ensure the TJA1027 switches successfully to Sleep mode, the sleep command (pin SLP\_N = LOW) must be maintained for at least  $t_{gotosleep}$ .

Sleep mode activation is independent of the levels on pins LIN or TXD. So the lowest possible power consumption can be guaranteed, even when there is a continuous dominant level on pins LIN and TXD.

### 7.2.3 Standby mode

Standby mode is activated automatically when a local or remote wake-up event occurs while the TJA1027 is in Sleep mode. In Standby mode, pin RXD is held LOW to provide an interrupt flag for the microcontroller.

### 7.2.4 Normal mode

In Normal mode, the TJA1027 can transmit and receive data via the LIN bus.

The receiver detects the data stream on the LIN bus input pin and transfers it via pin RXD to the microcontroller (see [Figure 6](#)): HIGH for a recessive level and LOW for a dominant level on the bus. The receiver has a supply-voltage related threshold with hysteresis and an integrated filter to suppress bus line noise.

The transmit data stream from the protocol controller is detected on pin TXD and is converted by the transmitter into an optimized bus signal shaped to minimize EME. The LIN bus output pin is pulled HIGH via an internal slave termination resistor. For a master application, an external resistor in series with a diode should be connected between pin  $V_{BAT}$  and pin LIN (see [Figure 6](#)).

If pin SLP\_N is pulled HIGH while the TJA1027 is in Sleep or Standby mode, the LIN transceiver switches to Normal mode after  $t_{gotonorm}$ .

### 7.3 Transceiver wake-up

#### 7.3.1 Remote wake-up via the LIN bus

A falling edge on pin LIN followed by a LOW level maintained for  $t_{wake(dom)LIN}$  followed by a rising edge on pin LIN triggers a remote wake-up (see Figure 4). It should be noted that the time period  $t_{wake(dom)LIN}$  is measured either in Normal mode while TXD is HIGH, or in Sleep mode irrespective of the status of pin TXD.

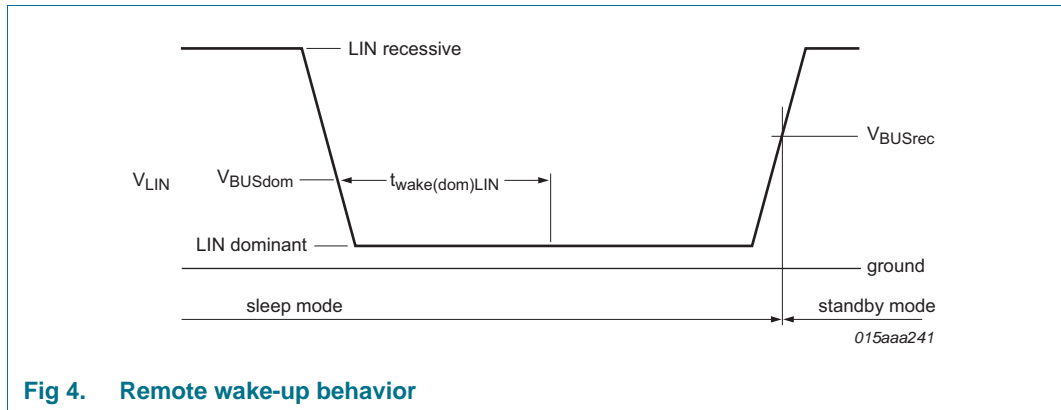

Fig 4. Remote wake-up behavior

#### 7.3.2 Wake-up via pin SLP\_N

If SLP\_N is held HIGH for  $t_{gotonorm}$ , the TJA1027 will switch from Sleep mode to Normal mode.

### 7.4 Operation during automotive cranking pulses

TJA1027 remains fully operational during automotive cranking pulses because the LIN transceiver is fully specified down to  $V_{BAT} = 5\text{ V}$ .

### 7.5 Operation when supply voltage is outside specified operating range

If  $V_{BAT} > 18\text{ V}$  or  $V_{BAT} < 5\text{ V}$ , the TJA1027 may remain operational, but parameter values cannot be guaranteed to remain within the operation ranges specified in Table 7 and Table 8.

In Normal mode:

- If the input level on pin TXD is HIGH, the LIN transmitter output on pin LIN will be recessive.
- If the input level on pin LIN is recessive, the receiver output on pin RXD will be HIGH.
- If the voltage on pin  $V_{BAT}$  rises to 27 V (e.g. during an automotive jump start), the total LIN network pull-up resistance should be greater than 680  $\Omega$  and the total LIN network capacitance should be less than 6.8 nF to ensure reliable LIN data transfer.
- If the voltage on pin  $V_{BAT}$  drops below the LOW-level  $V_{BAT}$  LOW threshold,  $V_{th(VBATL)L}$ , the LIN transmit path is interrupted and the LIN output remains recessive. The LIN transmit path is switched on again when  $V_{BAT}$  rises above  $V_{th(VBATL)H}$  and the input to pin TXD is recessive.



If the voltage on pin  $V_{BAT}$  drops below the LOW-level power-on reset threshold,  $V_{th(POR)L}$ , the TJA1027 switches to Reset mode (i.e. all output drivers are disabled and all inputs are ignored). The TJA1027 switches to Sleep mode if  $V_{BAT} > V_{th(POR)H}$ .

## 7.6 Fail-safe features

Pin TXD provides a pull-down to GND in order to force a predefined level on the transmit data input if the pin is disconnected.

Pin SLP\_N provides a pull-down to GND in order to force the transceiver into Sleep mode if pin SLP\_N is disconnected.

Pin RXD is set floating if  $V_{BAT}$  is disconnected.

The current in the transmitter output stage is limited in order to protect the transmitter against short circuits to pins  $V_{BAT}$  or GND.

A loss of power (pins  $V_{BAT}$  and GND) has no impact on the bus line or on the microcontroller. No reverse currents flow from the bus into pin LIN. The current path from  $V_{BAT}$  to LIN via the integrated LIN slave termination resistor remains. The LIN transceiver can be disconnected from the power supply without influencing the LIN bus.

The output driver on pin LIN is protected against overtemperature conditions. If the junction temperature exceeds the shutdown junction temperature,  $T_{j(sd)}$ , the thermal protection circuit disables the output driver. The driver is enabled again when the junction temperature falls below  $T_{j(sd)}$  and pin TXD is recessive.

The initial TXD dominant check prevents the bus line from being driven to a permanent dominant state (blocking all network communications) if pin TXD is forced permanently LOW by a hardware and/or software application failure. The TXD input level is checked after a transition to Normal mode. If TXD is LOW, the transmit path will remain disabled and will only be enabled when TXD goes HIGH.

## 8. Limiting values

**Table 5. Limiting values**

In accordance with the Absolute Maximum Rating System (IEC 60134). All voltages are referenced to pin GND, unless otherwise specified. Positive currents flow into the IC.

Symbol	Parameter	Conditions	Min	Max	Unit
V <sub>BAT</sub>	battery supply voltage		-0.3	+42	V
V <sub>TXD</sub>	voltage on pin TXD		-0.3	+7	V
V <sub>RXD</sub>	voltage on pin RXD		-0.3	+7	V
V <sub>SLP_N</sub>	voltage on pin SLP_N		-0.3	+7	V
V <sub>LIN</sub>	voltage on pin LIN	with respect to GND and V <sub>BAT</sub>	-42	+42	V
V <sub>ESD</sub>	electrostatic discharge voltage				
	according to IEC 61000-4-2	on pins LIN and V <sub>BAT</sub>	[1] -8	+8	kV
	human body model	on pins LIN and V <sub>BAT</sub>	[2] -8	+8	kV
		on pins TXD, RXD and SLP_N	[2] -2	+2	kV
	charge device model	all pins	-750	+750	V
	machine model	all pins	[3] -200	+200	V
T <sub>vj</sub>	virtual junction temperature		[4] -40	+150	°C
T <sub>stg</sub>	storage temperature		-55	+150	°C

[1] Equivalent to discharging a 150 pF capacitor through a 330 Ω resistor.

[2] Equivalent to discharging a 100 pF capacitor through a 1.5 kΩ resistor.

[3] Equivalent to discharging a 200 pF capacitor through a 10 Ω resistor and a 0.75 μH coil.

[4] Junction temperature in accordance with IEC 60747-1. An alternative definition is:  $T_j = T_{amb} + P \times R_{th(j-a)}$ , where  $R_{th(j-a)}$  is a fixed value. The rating for T<sub>vj</sub> limits the allowable combinations of power dissipation (P) and ambient temperature (T<sub>amb</sub>).

## 9. Thermal characteristics

**Table 6. Thermal characteristics**

According to IEC 60747-1.

Symbol	Parameter	Conditions	Typ	Unit
R <sub>th(j-a)</sub>	thermal resistance from junction to ambient	SO8 package; in free air	145	K/W
		HVSON8 package; in free air	50	K/W

## 10. Static characteristics

**Table 7. Static characteristics**

$V_{BAT} = 5\text{ V to }18\text{ V}$ ;  $T_{vj} = -40\text{ °C to }+150\text{ °C}$ ;  $R_{L(LIN-VBAT)} = 500\ \Omega$ ; all voltages are referenced to pin GND; positive currents flow into the IC; typical values are given at  $V_{BAT} = 12\text{ V}$ ; unless otherwise specified.<sup>[1]</sup>

Symbol	Parameter	Conditions	Min	Typ	Max	Unit
<b>Supply</b>						
$V_{BAT}$	battery supply voltage		5	-	18	V
$I_{BAT}$	battery supply current	Sleep mode; bus recessive; $V_{LIN} = V_{BAT}$ ; $V_{SLP\_N} = 0\text{ V}$	2.5	7	10	$\mu\text{A}$
		Sleep mode; bus dominant; $V_{LIN} = 0\text{ V}$ ; $V_{BAT} = 12\text{ V}$ ; $V_{SLP\_N} = 0\text{ V}$	150	400	1200	$\mu\text{A}$
		Standby mode; bus recessive; $V_{LIN} = V_{BAT}$ ; $V_{SLP\_N} = 0\text{ V}$	2.5	7	10	$\mu\text{A}$
		Standby mode; bus dominant; $V_{LIN} = 0\text{ V}$ ; $V_{BAT} = 12\text{ V}$ ; $V_{SLP\_N} = 0\text{ V}$	[2] 100	300	1000	$\mu\text{A}$
		Normal mode; bus recessive; $V_{LIN} = V_{BAT}$ ; $V_{SLP\_N} = 5\text{ V}$ ; $V_{TXD} = 5\text{ V}$	200	800	1600	$\mu\text{A}$
		Normal mode; bus dominant; $V_{TXD} = 0\text{ V}$ ; $V_{SLP\_N} = 5\text{ V}$ ; $V_{BAT} = 12\text{ V}$	1	2	4	mA
<b>Undervoltage reset</b>						
$V_{th(POR)L}$	LOW-level power-on reset threshold voltage	power-on reset	1.6	3.1	3.9	V
$V_{th(POR)H}$	HIGH-level power-on reset threshold voltage		2.3	3.4	4.3	V
$V_{hys(POR)}$	power-on reset hysteresis voltage		[2] 0.05	0.3	1	V
$V_{th(VBATL)L}$	LOW-level $V_{BAT}$ LOW threshold voltage		3.9	4.4	4.7	V
$V_{th(VBATL)H}$	HIGH-level $V_{BAT}$ LOW threshold voltage		4.2	4.7	4.9	V
$V_{hys(VBATL)}$	$V_{BAT}$ LOW hysteresis voltage		[2] 0.15	0.3	0.6	V
<b>Pins TXD and SLP_N</b>						
$V_{IH}$	HIGH-level input voltage		2	-	7	V
$V_{IL}$	LOW-level input voltage		-0.3	-	+0.8	V
$V_{hys}$	hysteresis voltage		[2] 50	200	400	mV
$R_{pd}$	pull-down resistance	on TXD	50	125	325	k $\Omega$
		on SLP_N	100	250	650	k $\Omega$
<b>Pin RXD (open-drain)</b>						
$I_{OL}$	LOW-level output current	$V_{RXD} = 0.4\text{ V}$	2	-	-	mA
$I_{LH}$	HIGH-level leakage current		[2] -5	-	+5	$\mu\text{A}$

**Table 7. Static characteristics ...continued**

$V_{BAT} = 5\text{ V to }18\text{ V}$ ;  $T_{vj} = -40\text{ °C to }+150\text{ °C}$ ;  $R_{L(LIN-VBAT)} = 500\ \Omega$ ; all voltages are referenced to pin GND; positive currents flow into the IC; typical values are given at  $V_{BAT} = 12\text{ V}$ ; unless otherwise specified.<sup>[1]</sup>

Symbol	Parameter	Conditions	Min	Typ	Max	Unit	
<b>Pin LIN</b>							
$I_{BUS\_LIM}$	current limitation for driver dominant state	$V_{BAT} = 18\text{ V}$ ; $V_{LIN} = 18\text{ V}$ ; $V_{TXD} = 0\text{ V}$	40	-	100	mA	
$I_{BUS\_PAS\_dom}$	receiver dominant input leakage current including pull-up resistor	$V_{BAT} = 12\text{ V}$ ; $V_{LIN} = 0\text{ V}$ ; $V_{TXD} = 5\text{ V}$	[2] -600	-	-	$\mu\text{A}$	
$I_{BUS\_PAS\_rec}$	receiver recessive input leakage current	$V_{BAT} = 5\text{ V}$ ; $V_{LIN} = 18\text{ V}$ ; $V_{TXD} = 5\text{ V}$	[2] -	0	1	$\mu\text{A}$	
$I_{BUS\_NO\_GND}$	loss-of-ground bus current	$V_{BAT} = 18\text{ V}$ ; $V_{LIN} = 0\text{ V}$	[2] -750	-	+10	$\mu\text{A}$	
$I_{BUS\_NO\_BAT}$	loss-of-battery bus current	$V_{BAT} = 0\text{ V}$ ; $V_{LIN} = 18\text{ V}$	[2] -	-	1	$\mu\text{A}$	
$V_{BUSdom}$	receiver dominant state		[2] -	-	$0.4V_{BAT}$	V	
$V_{BUSrec}$	receiver recessive state		[2] $0.6V_{BAT}$	-	-	V	
$V_{BUS\_CNT}$	receiver center voltage	$V_{BUS\_CNT} =$ $(V_{BUSdom} + V_{BUSrec}) / 2$		$0.475V_{BAT}$	$0.5V_{BAT}$	$0.525V_{BAT}$	V
$V_{HYS}$	receiver hysteresis voltage	$V_{HYS} = V_{BUSrec} - V_{BUSdom}$	[2] -	-	$0.175V_{BAT}$	V	
$V_{SerDiode}$	voltage drop at the serial diode	in pull-up path with $R_{slave}$ ; $I_{SerDiode} = 0.9\text{ mA}$	[2] 0.4	-	1.0	V	
$V_{O(dom)}$	dominant output voltage	Normal mode; $V_{TXD} = 0\text{ V}$ ; $V_{BAT} = 7.0\text{ V}$	[2] -	-	1.4	V	
		Normal mode; $V_{TXD} = 0\text{ V}$ ; $V_{BAT} = 18\text{ V}$	[2] -	-	2.0	V	
$R_{slave}$	slave resistance		20	30	60	k $\Omega$	
$C_{LIN}$	capacitance on pin LIN	with respect to GND	[2] -	-	20	pF	
<b>Thermal shutdown</b>							
$T_{j(sd)}$	shutdown junction temperature		[2] 150	-	200	$^{\circ}\text{C}$	

[1] All parameters are guaranteed over the virtual junction temperature range by design. Factory testing uses correlated test conditions to cover the specified temperature and power supply voltage range.

[2] Not tested in production; guaranteed by design.

## 11. Dynamic characteristics

**Table 8. Dynamic characteristics**

$V_{BAT} = 5\text{ V to }18\text{ V}$ ;  $T_{vj} = -40\text{ }^{\circ}\text{C to }+150\text{ }^{\circ}\text{C}$ ;  $R_{L(LIN-VBAT)} = 500\ \Omega$ ; all voltages are referenced to pin GND; positive currents flow into the IC; typical values are given at  $V_{BAT} = 12\text{ V}$ , unless otherwise specified.<sup>[1]</sup>

Symbol	Parameter	Conditions	Min	Typ	Max	Unit	
<b>Duty cycles</b>							
$\delta 1$	duty cycle 1	$V_{th(rec)(max)} = 0.744 \times V_{BAT}$ ; $V_{th(dom)(max)} = 0.581 \times V_{BAT}$ ; $t_{bit} = 50\ \mu\text{s}$ ; $V_{BAT} = 7\text{ V to }18\text{ V}$	[2][4][5]	0.396	-	-	
		$V_{th(rec)(max)} = 0.768 \times V_{BAT}$ ; $V_{th(dom)(max)} = 0.6 \times V_{BAT}$ ; $t_{bit} = 50\ \mu\text{s}$ ; $V_{BAT} = 5\text{ V to }7\text{ V}$	[2][4][5]	0.396	-	-	
$\delta 2$	duty cycle 2	$V_{th(rec)(min)} = 0.422 \times V_{BAT}$ ; $V_{th(dom)(min)} = 0.284 \times V_{BAT}$ ; $t_{bit} = 50\ \mu\text{s}$ ; $V_{BAT} = 7.6\text{ V to }18\text{ V}$	[3][4][5]	-	-	0.581	
		$V_{th(rec)(min)} = 0.405 \times V_{BAT}$ ; $V_{th(dom)(min)} = 0.271 \times V_{BAT}$ ; $t_{bit} = 50\ \mu\text{s}$ ; $V_{BAT} = 5.6\text{ V to }7.6\text{ V}$	[3][4][5]	-	-	0.581	
$\delta 3$	duty cycle 3	$V_{th(rec)(max)} = 0.778 \times V_{BAT}$ ; $V_{th(dom)(max)} = 0.616 \times V_{BAT}$ ; $t_{bit} = 96\ \mu\text{s}$ ; $V_{BAT} = 7\text{ V to }18\text{ V}$	[2][4][5]	0.417	-	-	
		$V_{th(rec)(max)} = 0.805 \times V_{BAT}$ ; $V_{th(dom)(max)} = 0.637 \times V_{BAT}$ ; $t_{bit} = 96\ \mu\text{s}$ ; $V_{BAT} = 5\text{ V to }7\text{ V}$	[2][4][5]	0.417	-	-	
$\delta 4$	duty cycle 4	$V_{th(rec)(min)} = 0.389 \times V_{BAT}$ ; $V_{th(dom)(min)} = 0.251 \times V_{BAT}$ ; $t_{bit} = 96\ \mu\text{s}$ ; $V_{BAT} = 7.6\text{ V to }18\text{ V}$	[3][4][5]	-	-	0.590	
		$V_{th(rec)(min)} = 0.372 \times V_{BAT}$ ; $V_{th(dom)(min)} = 0.238 \times V_{BAT}$ ; $t_{bit} = 96\ \mu\text{s}$ ; $V_{BAT} = 5.6\text{ V to }7.6\text{ V}$	[3][4][5]	-	-	0.590	
<b>Timing characteristics</b>							
$t_{rx\_pd}$	receiver propagation delay	rising and falling; $C_{RXD} = 20\text{ pF}$ ; $R_{RXD} = 2.4\text{ k}\Omega$	[5]	-	-	6	$\mu\text{s}$
$t_{rx\_sym}$	receiver propagation delay symmetry	$C_{RXD} = 20\text{ pF}$ ; $R_{RXD} = 2.4\text{ k}\Omega$ ; rising edge with respect to falling edge	[5]	-2	-	+2	$\mu\text{s}$
$t_{wake(dom)LIN}$	LIN dominant wake-up time	Sleep mode		30	80	150	$\mu\text{s}$
$t_{gotonorm}$	go to normal time	time period for mode change from Sleep or Standby mode to Normal mode		2	6	10	$\mu\text{s}$
$t_{init(norm)}$	normal mode initialization time			7	-	20	$\mu\text{s}$
$t_{gotosleep}$	go to sleep time	time period for mode change from Normal to Sleep mode		2	6	10	$\mu\text{s}$

[1] All parameters are guaranteed over the virtual junction temperature range by design. Factory testing uses correlated test conditions to cover the specified temperature and power supply voltage ranges.

[2]  $\delta 1, \delta 3 = \frac{t_{bus(rec)(min)}}{2 \times t_{bit}}$ . Variable  $t_{bus(rec)(min)}$  is illustrated in the LIN timing diagram in [Figure 5](#).

- [3]  $\delta 2, \delta 4 = \frac{t_{bus(rec)(max)}}{2 \times t_{bit}}$ . Variable  $t_{bus(rec)(max)}$  is illustrated in the LIN timing diagram in [Figure 5](#).
- [4] Bus load conditions:  $C_{BUS} = 1 \text{ nF}$  and  $R_{BUS} = 1 \text{ k}\Omega$ ;  $C_{BUS} = 6.8 \text{ nF}$  and  $R_{BUS} = 660 \text{ }\Omega$ ;  $C_{BUS} = 10 \text{ nF}$  and  $R_{BUS} = 500 \text{ }\Omega$ .
- [5] See timing diagram in [Figure 5](#).

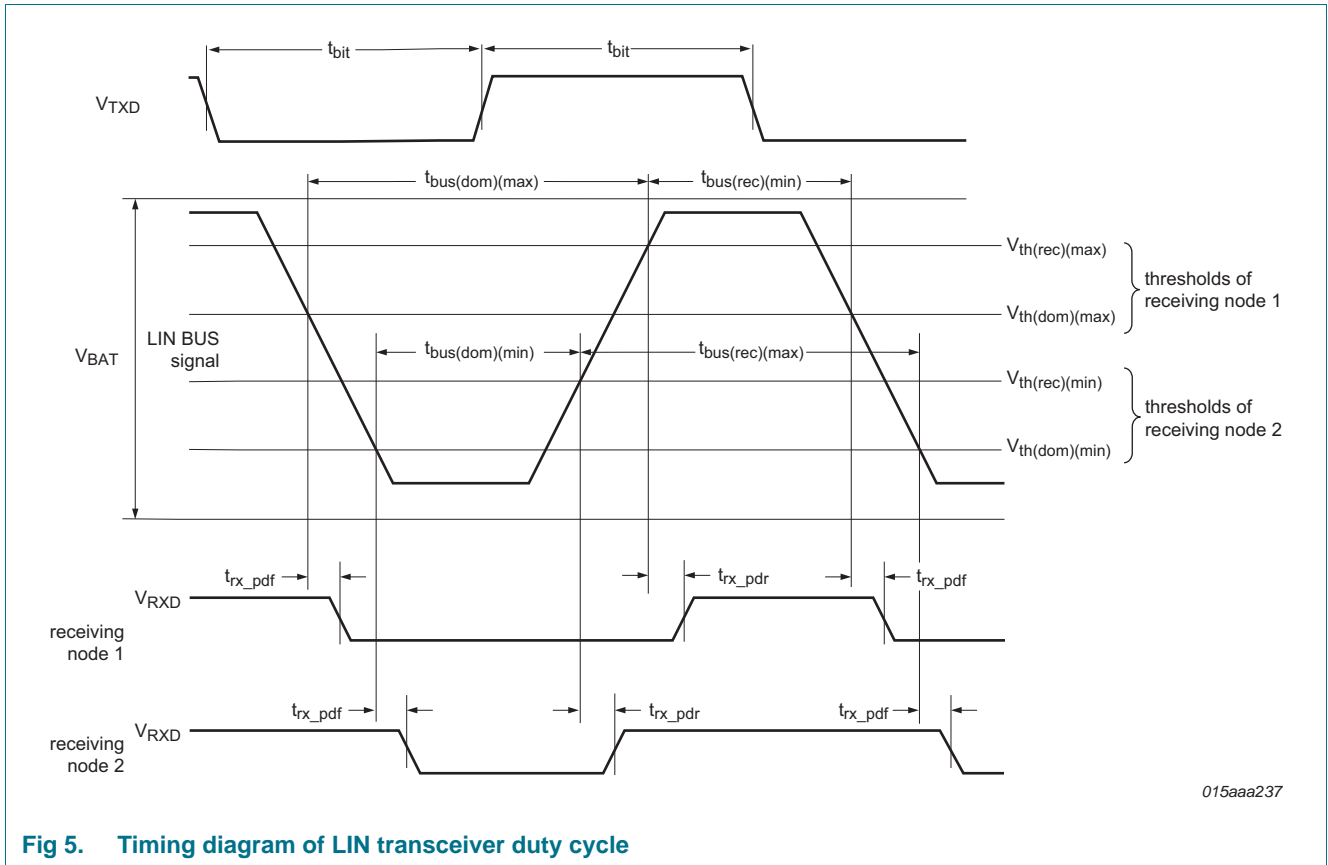

**Fig 5. Timing diagram of LIN transceiver duty cycle**

## 12. Application information

### 12.1 Application diagram

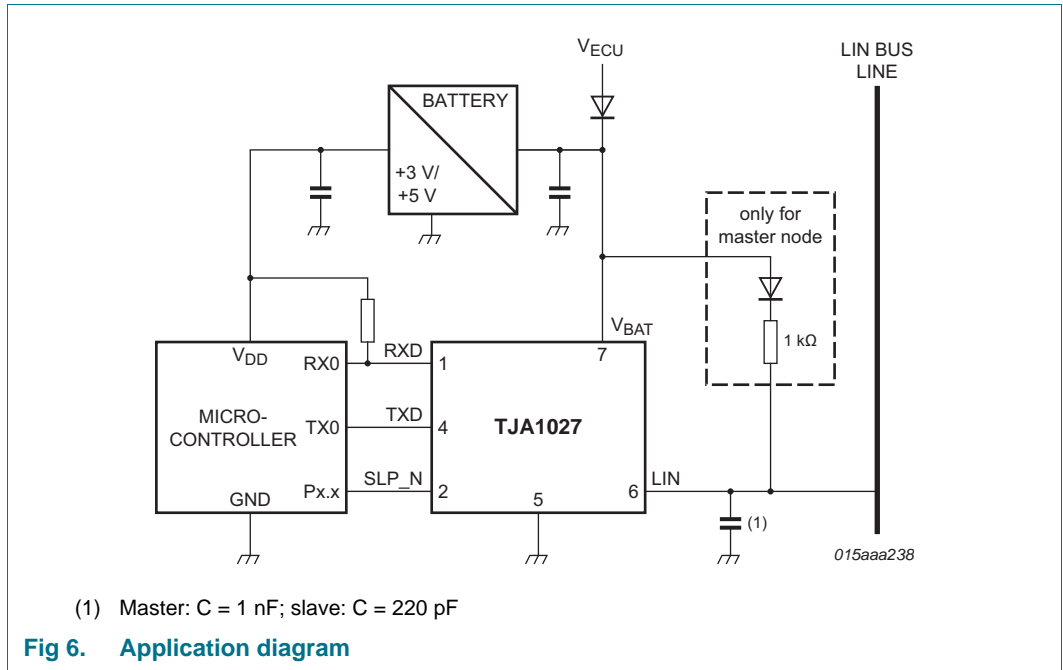

### 12.2 ESD robustness according to LIN EMC test specification

ESD robustness (IEC 61000-4-2) has been tested by an external test house according to the LIN EMC test specification (part of Conformance Test Specification Package for LIN 2.1, October 10th, 2008). The test report is available on request.

Table 9. ESD robustness (IEC 61000-4-2) according to LIN EMC test specification

Pin	Test configuration	Value	Unit
LIN	no capacitor connected to LIN pin	±13	kV
	220 pF capacitor connected to LIN pin	±12	kV
V <sub>BAT</sub>	100 nF capacitor connected to V <sub>BAT</sub> pin	>  15	kV

### 12.3 Hardware requirements for LIN interfaces in automotive applications

The TJA1027 satisfies the "Hardware Requirements for LIN, CAN and FlexRay Interfaces in Automotive Applications", Version 1.1, December 2009.

## 13. Test information

### 13.1 Quality information

This product has been qualified in accordance with the Automotive Electronics Council (AEC) standard Q100 Rev-G - Failure mechanism based stress test qualification for integrated circuits, and is suitable for use in automotive applications.

14. Package outline

SO8: plastic small outline package; 8 leads; body width 3.9 mm

SOT96-1

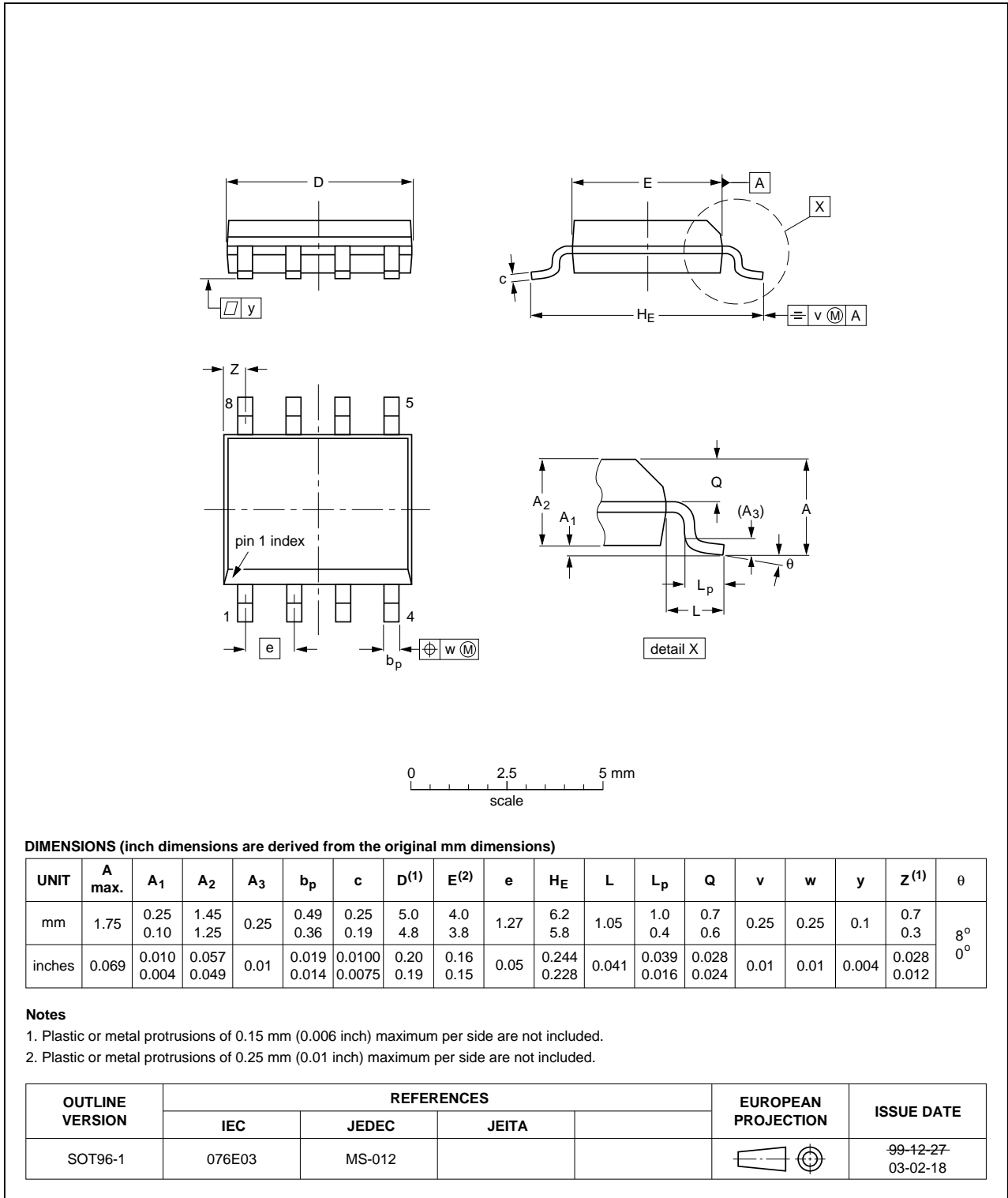

Fig 7. Package outline SOT96-1 (SO8)



HVSON8: plastic thermal enhanced very thin small outline package; no leads;  
8 terminals; body 3 x 3 x 0.85 mm

SOT782-1

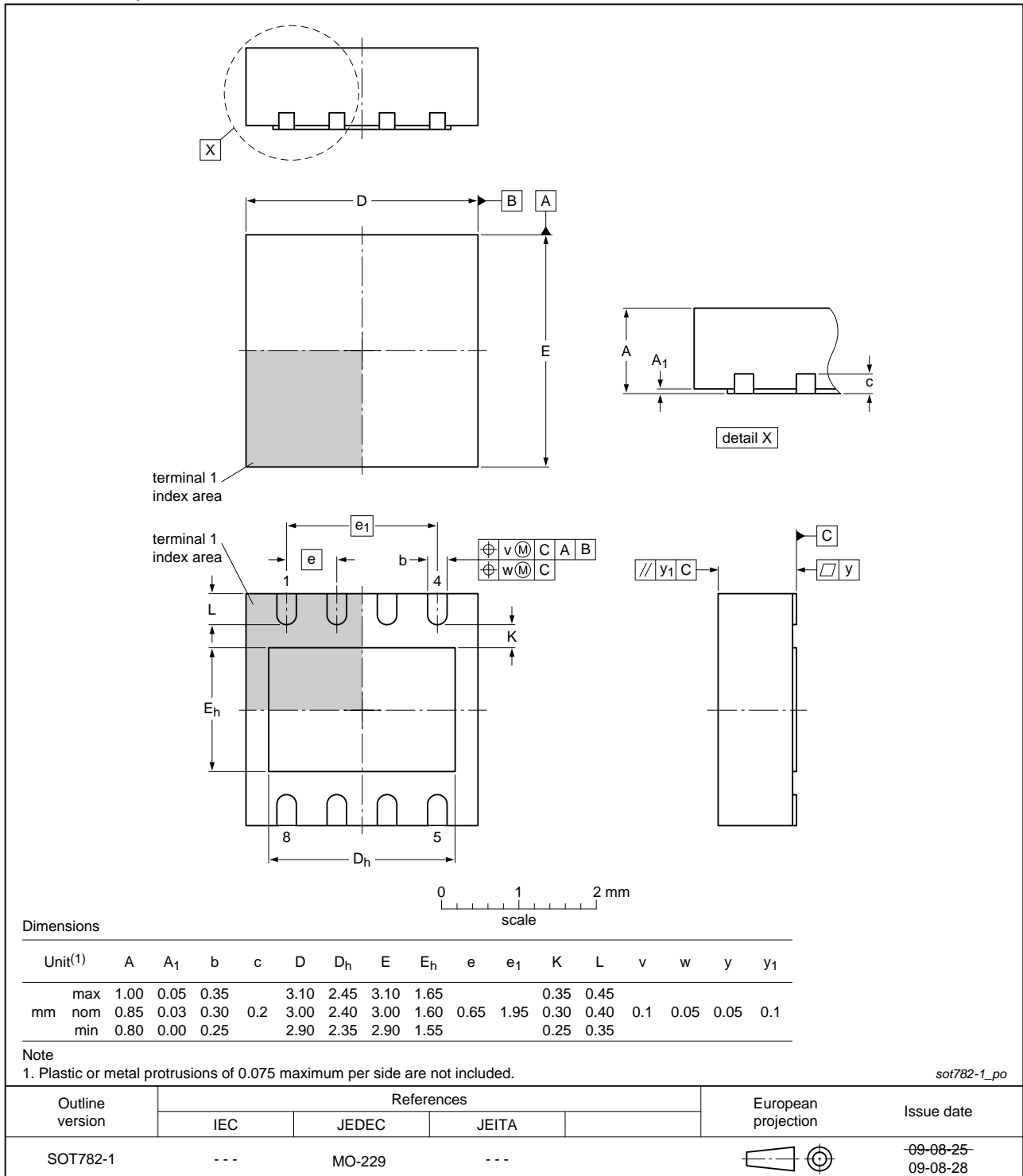

Fig 8. Package outline SOT782-1 (HVSON8)

## 15. Handling information

All input and output pins are protected against ElectroStatic Discharge (ESD) under normal handling. When handling ensure that the appropriate precautions are taken as described in *JESD625-A* or equivalent standards.

## 16. Soldering of SMD packages

This text provides a very brief insight into a complex technology. A more in-depth account of soldering ICs can be found in Application Note *AN10365 "Surface mount reflow soldering description"*.

### 16.1 Introduction to soldering

Soldering is one of the most common methods through which packages are attached to Printed Circuit Boards (PCBs), to form electrical circuits. The soldered joint provides both the mechanical and the electrical connection. There is no single soldering method that is ideal for all IC packages. Wave soldering is often preferred when through-hole and Surface Mount Devices (SMDs) are mixed on one printed wiring board; however, it is not suitable for fine pitch SMDs. Reflow soldering is ideal for the small pitches and high densities that come with increased miniaturization.

### 16.2 Wave and reflow soldering

Wave soldering is a joining technology in which the joints are made by solder coming from a standing wave of liquid solder. The wave soldering process is suitable for the following:

- Through-hole components
- Leaded or leadless SMDs, which are glued to the surface of the printed circuit board

Not all SMDs can be wave soldered. Packages with solder balls, and some leadless packages which have solder lands underneath the body, cannot be wave soldered. Also, leaded SMDs with leads having a pitch smaller than ~0.6 mm cannot be wave soldered, due to an increased probability of bridging.

The reflow soldering process involves applying solder paste to a board, followed by component placement and exposure to a temperature profile. Leaded packages, packages with solder balls, and leadless packages are all reflow solderable.

Key characteristics in both wave and reflow soldering are:

- Board specifications, including the board finish, solder masks and vias
- Package footprints, including solder thieves and orientation
- The moisture sensitivity level of the packages
- Package placement
- Inspection and repair
- Lead-free soldering versus SnPb soldering

### 16.3 Wave soldering

Key characteristics in wave soldering are:

- Process issues, such as application of adhesive and flux, clinching of leads, board transport, the solder wave parameters, and the time during which components are exposed to the wave
- Solder bath specifications, including temperature and impurities

### 16.4 Reflow soldering

Key characteristics in reflow soldering are:

- Lead-free versus SnPb soldering; note that a lead-free reflow process usually leads to higher minimum peak temperatures (see [Figure 9](#)) than a SnPb process, thus reducing the process window
- Solder paste printing issues including smearing, release, and adjusting the process window for a mix of large and small components on one board
- Reflow temperature profile; this profile includes preheat, reflow (in which the board is heated to the peak temperature) and cooling down. It is imperative that the peak temperature is high enough for the solder to make reliable solder joints (a solder paste characteristic). In addition, the peak temperature must be low enough that the packages and/or boards are not damaged. The peak temperature of the package depends on package thickness and volume and is classified in accordance with [Table 10](#) and [11](#)

**Table 10. SnPb eutectic process (from J-STD-020D)**

Package thickness (mm)	Package reflow temperature (°C)	
	Volume (mm <sup>3</sup> )	
	< 350	≥ 350
< 2.5	235	220
≥ 2.5	220	220

**Table 11. Lead-free process (from J-STD-020D)**

Package thickness (mm)	Package reflow temperature (°C)		
	Volume (mm <sup>3</sup> )		
	< 350	350 to 2000	> 2000
< 1.6	260	260	260
1.6 to 2.5	260	250	245
> 2.5	250	245	245

Moisture sensitivity precautions, as indicated on the packing, must be respected at all times.

Studies have shown that small packages reach higher temperatures during reflow soldering, see [Figure 9](#).

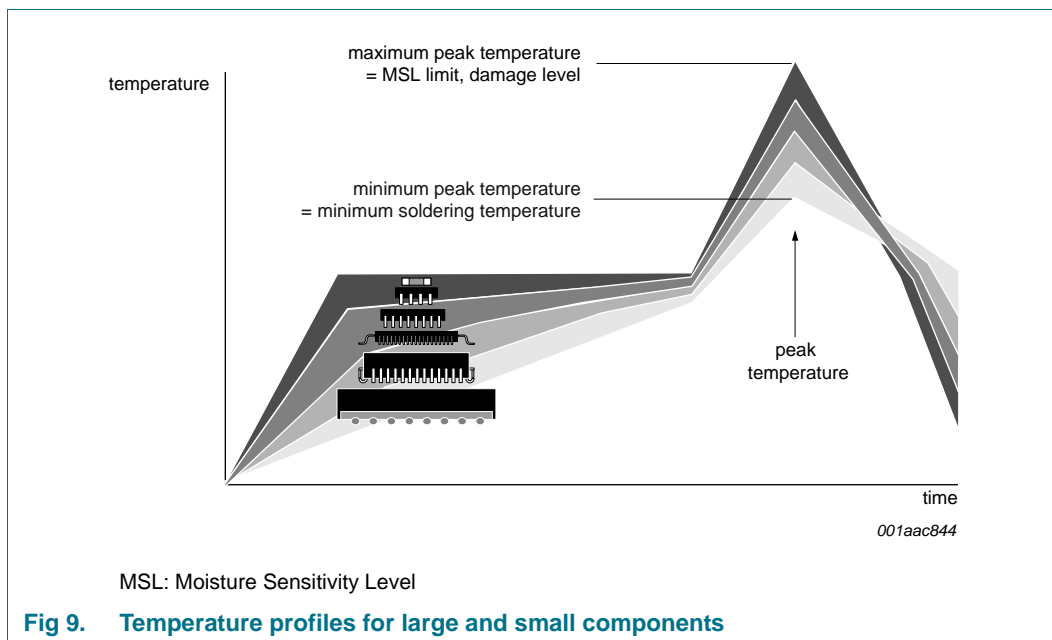

For further information on temperature profiles, refer to Application Note *AN10365* “*Surface mount reflow soldering description*”.

## 17. Soldering of HVSON packages

[Section 16](#) contains a brief introduction to the techniques most commonly used to solder Surface Mounted Devices (SMD). A more detailed discussion on soldering HVSON leadless package ICs can be found in the following application notes:

- *AN10365* “*Surface mount reflow soldering description*”
- *AN10366* “*HVQFN application information*”

## 18. Revision history

Table 12. Revision history

Document ID	Release date	Data sheet status	Change notice	Supersedes
TJA1027 v.2	20130424	Product data sheet	-	TJA1027 v.1
Modifications:		<ul style="list-style-type: none"><li>• text in Title, <a href="#">Section 1</a>, <a href="#">Section 2.1</a>, <a href="#">Section 7.1</a> revised to include LIN 2.2A compliance</li><li>• text in <a href="#">Section 7.1</a> revised to be consistent with TJA1029</li><li>• <a href="#">Figure 2</a>: revised/resized</li><li>• <a href="#">Table 3</a>, <a href="#">Table note 1</a>: revised</li><li>• <a href="#">Figure 4</a>: revised</li><li>• <a href="#">Table 7</a>: revised measurement conditions for parameter I<sub>BUS_NO_BAT</sub></li><li>• <a href="#">Section 13.1</a>: text revised</li></ul>		
TJA1027 v.1	20111020	Product data sheet	-	-

## 19. Legal information

### 19.1 Data sheet status

Document status <sup>[1][2]</sup>	Product status <sup>[3]</sup>	Definition
Objective [short] data sheet	Development	This document contains data from the objective specification for product development.
Preliminary [short] data sheet	Qualification	This document contains data from the preliminary specification.
Product [short] data sheet	Production	This document contains the product specification.

[1] Please consult the most recently issued document before initiating or completing a design.

[2] The term 'short data sheet' is explained in section "Definitions".

[3] The product status of device(s) described in this document may have changed since this document was published and may differ in case of multiple devices. The latest product status information is available on the Internet at URL <http://www.nxp.com>.

### 19.2 Definitions

**Draft** — The document is a draft version only. The content is still under internal review and subject to formal approval, which may result in modifications or additions. NXP Semiconductors does not give any representations or warranties as to the accuracy or completeness of information included herein and shall have no liability for the consequences of use of such information.

**Short data sheet** — A short data sheet is an extract from a full data sheet with the same product type number(s) and title. A short data sheet is intended for quick reference only and should not be relied upon to contain detailed and full information. For detailed and full information see the relevant full data sheet, which is available on request via the local NXP Semiconductors sales office. In case of any inconsistency or conflict with the short data sheet, the full data sheet shall prevail.

**Product specification** — The information and data provided in a Product data sheet shall define the specification of the product as agreed between NXP Semiconductors and its customer, unless NXP Semiconductors and customer have explicitly agreed otherwise in writing. In no event however, shall an agreement be valid in which the NXP Semiconductors product is deemed to offer functions and qualities beyond those described in the Product data sheet.

### 19.3 Disclaimers

**Limited warranty and liability** — Information in this document is believed to be accurate and reliable. However, NXP Semiconductors does not give any representations or warranties, expressed or implied, as to the accuracy or completeness of such information and shall have no liability for the consequences of use of such information. NXP Semiconductors takes no responsibility for the content in this document if provided by an information source outside of NXP Semiconductors.

In no event shall NXP Semiconductors be liable for any indirect, incidental, punitive, special or consequential damages (including - without limitation - lost profits, lost savings, business interruption, costs related to the removal or replacement of any products or rework charges) whether or not such damages are based on tort (including negligence), warranty, breach of contract or any other legal theory.

Notwithstanding any damages that customer might incur for any reason whatsoever, NXP Semiconductors' aggregate and cumulative liability towards customer for the products described herein shall be limited in accordance with the *Terms and conditions of commercial sale* of NXP Semiconductors.

**Right to make changes** — NXP Semiconductors reserves the right to make changes to information published in this document, including without limitation specifications and product descriptions, at any time and without notice. This document supersedes and replaces all information supplied prior to the publication hereof.

**Suitability for use in automotive applications** — This NXP Semiconductors product has been qualified for use in automotive applications. Unless otherwise agreed in writing, the product is not designed, authorized or warranted to be suitable for use in life support, life-critical or safety-critical systems or equipment, nor in applications where failure or malfunction of an NXP Semiconductors product can reasonably be expected to result in personal injury, death or severe property or environmental damage. NXP Semiconductors and its suppliers accept no liability for inclusion and/or use of NXP Semiconductors products in such equipment or applications and therefore such inclusion and/or use is at the customer's own risk.

**Applications** — Applications that are described herein for any of these products are for illustrative purposes only. NXP Semiconductors makes no representation or warranty that such applications will be suitable for the specified use without further testing or modification.

Customers are responsible for the design and operation of their applications and products using NXP Semiconductors products, and NXP Semiconductors accepts no liability for any assistance with applications or customer product design. It is customer's sole responsibility to determine whether the NXP Semiconductors product is suitable and fit for the customer's applications and products planned, as well as for the planned application and use of customer's third party customer(s). Customers should provide appropriate design and operating safeguards to minimize the risks associated with their applications and products.

NXP Semiconductors does not accept any liability related to any default, damage, costs or problem which is based on any weakness or default in the customer's applications or products, or the application or use by customer's third party customer(s). Customer is responsible for doing all necessary testing for the customer's applications and products using NXP Semiconductors products in order to avoid a default of the applications and the products or of the application or use by customer's third party customer(s). NXP does not accept any liability in this respect.

**Limiting values** — Stress above one or more limiting values (as defined in the Absolute Maximum Ratings System of IEC 60134) will cause permanent damage to the device. Limiting values are stress ratings only and (proper) operation of the device at these or any other conditions above those given in the Recommended operating conditions section (if present) or the Characteristics sections of this document is not warranted. Constant or repeated exposure to limiting values will permanently and irreversibly affect the quality and reliability of the device.

**Terms and conditions of commercial sale** — NXP Semiconductors products are sold subject to the general terms and conditions of commercial sale, as published at <http://www.nxp.com/profile/terms>, unless otherwise agreed in a valid written individual agreement. In case an individual agreement is concluded only the terms and conditions of the respective agreement shall apply. NXP Semiconductors hereby expressly objects to applying the customer's general terms and conditions with regard to the purchase of NXP Semiconductors products by customer.

**No offer to sell or license** — Nothing in this document may be interpreted or construed as an offer to sell products that is open for acceptance or the grant, conveyance or implication of any license under any copyrights, patents or other industrial or intellectual property rights.

**Export control** — This document as well as the item(s) described herein may be subject to export control regulations. Export might require a prior authorization from competent authorities.

**Quick reference data** — The Quick reference data is an extract of the product data given in the Limiting values and Characteristics sections of this document, and as such is not complete, exhaustive or legally binding.

## 19.4 Trademarks

Notice: All referenced brands, product names, service names and trademarks are the property of their respective owners.

## 20. Contact information

---

For more information, please visit: <http://www.nxp.com>

For sales office addresses, please send an email to: [salesaddresses@nxp.com](mailto:salesaddresses@nxp.com)

## 21. Contents

<b>1</b>	<b>General description</b> . . . . .	<b>1</b>	<b>18</b>	<b>Revision history</b> . . . . .	<b>21</b>
<b>2</b>	<b>Features and benefits</b> . . . . .	<b>1</b>	<b>19</b>	<b>Legal information</b> . . . . .	<b>22</b>
2.1	General . . . . .	1	19.1	Data sheet status . . . . .	22
2.2	Protection . . . . .	2	19.2	Definitions . . . . .	22
<b>3</b>	<b>Quick reference data</b> . . . . .	<b>2</b>	19.3	Disclaimers . . . . .	22
<b>4</b>	<b>Ordering information</b> . . . . .	<b>2</b>	19.4	Trademarks . . . . .	23
<b>5</b>	<b>Block diagram</b> . . . . .	<b>3</b>	<b>20</b>	<b>Contact information</b> . . . . .	<b>23</b>
<b>6</b>	<b>Pinning information</b> . . . . .	<b>4</b>	<b>21</b>	<b>Contents</b> . . . . .	<b>24</b>
6.1	Pinning . . . . .	4			
6.2	Pin description . . . . .	4			
<b>7</b>	<b>Functional description</b> . . . . .	<b>5</b>			
7.1	LIN 2.x/SAE J2602 compliant . . . . .	5			
7.2	Operating modes . . . . .	5			
7.2.1	Reset mode . . . . .	7			
7.2.2	Sleep mode . . . . .	7			
7.2.3	Standby mode . . . . .	7			
7.2.4	Normal mode . . . . .	7			
7.3	Transceiver wake-up . . . . .	8			
7.3.1	Remote wake-up via the LIN bus . . . . .	8			
7.3.2	Wake-up via pin SLP_N . . . . .	8			
7.4	Operation during automotive cranking pulses . . . . .	8			
7.5	Operation when supply voltage is outside specified operating range . . . . .	8			
7.6	Fail-safe features . . . . .	9			
<b>8</b>	<b>Limiting values</b> . . . . .	<b>10</b>			
<b>9</b>	<b>Thermal characteristics</b> . . . . .	<b>10</b>			
<b>10</b>	<b>Static characteristics</b> . . . . .	<b>11</b>			
<b>11</b>	<b>Dynamic characteristics</b> . . . . .	<b>13</b>			
<b>12</b>	<b>Application information</b> . . . . .	<b>15</b>			
12.1	Application diagram . . . . .	15			
12.2	ESD robustness according to LIN EMC test specification . . . . .	15			
12.3	Hardware requirements for LIN interfaces in automotive applications . . . . .	15			
<b>13</b>	<b>Test information</b> . . . . .	<b>15</b>			
13.1	Quality information . . . . .	15			
<b>14</b>	<b>Package outline</b> . . . . .	<b>16</b>			
<b>15</b>	<b>Handling information</b> . . . . .	<b>18</b>			
<b>16</b>	<b>Soldering of SMD packages</b> . . . . .	<b>18</b>			
16.1	Introduction to soldering . . . . .	18			
16.2	Wave and reflow soldering . . . . .	18			
16.3	Wave soldering . . . . .	18			
16.4	Reflow soldering . . . . .	19			
<b>17</b>	<b>Soldering of HVSON packages</b> . . . . .	<b>20</b>			

Please be aware that important notices concerning this document and the product(s) described herein, have been included in section 'Legal information'.

© NXP B.V. 2013.

All rights reserved.

For more information, please visit: <http://www.nxp.com>

For sales office addresses, please send an email to: [salesaddresses@nxp.com](mailto:salesaddresses@nxp.com)

Date of release: 24 April 2013

Document identifier: TJA1027



# Mouser Electronics

Authorized Distributor

Click to View Pricing, Inventory, Delivery & Lifecycle Information:

[NXP:](#)

[TJA1027TK/20,118](#) [TJA1027T/20,118](#) [TJA1027TK/20/1J](#) [TJA1027T/20/1J](#)