

Sep.1.2020 Copyright 2020 HIROSE ELECTRIC CO., LTD. All Rights Reserved.
In case of consideration for using Automotive equipment / device which demand high reliability, kindly contact our sales window correspondents.

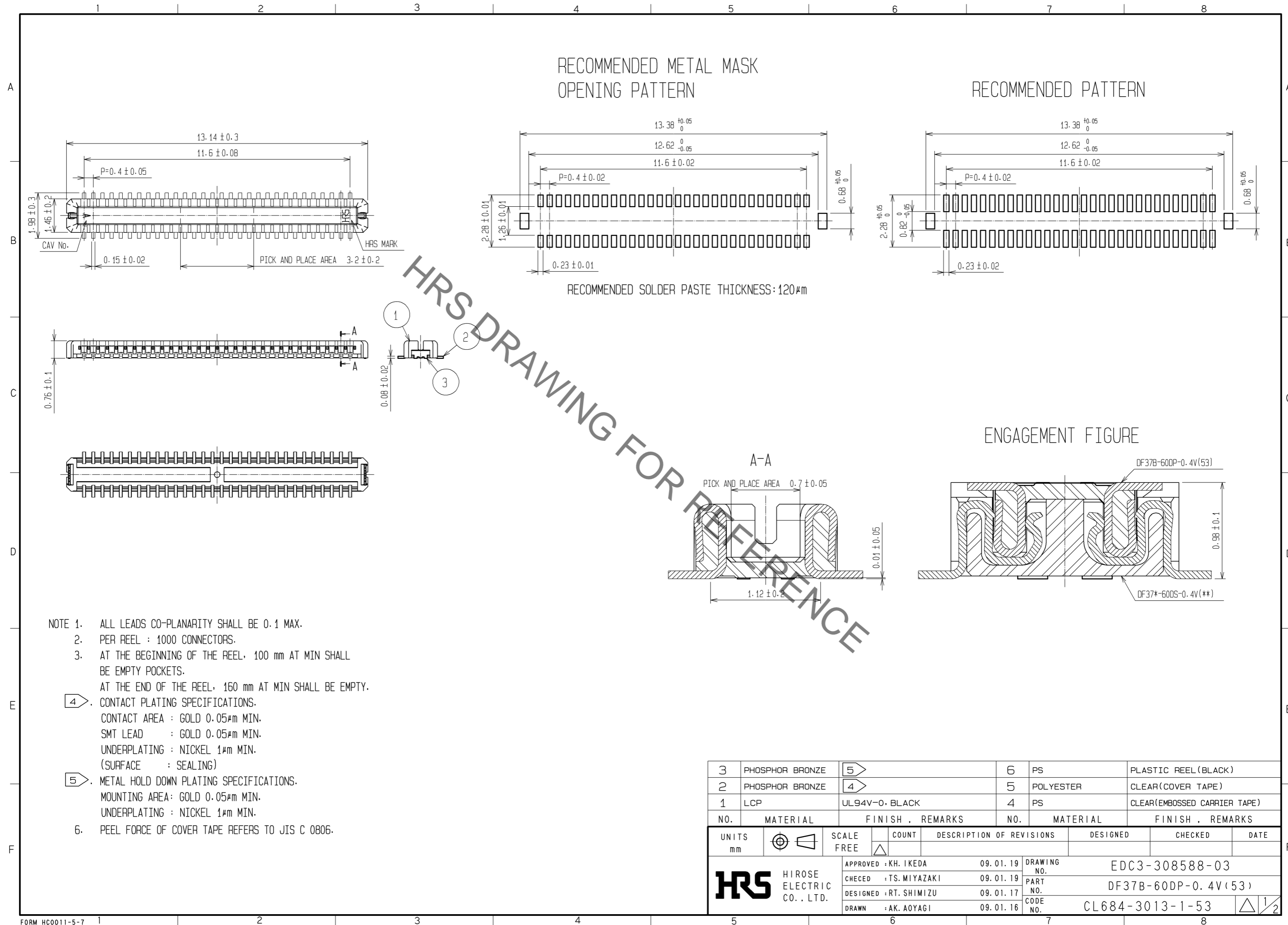

- NOTE 1. ALL LEADS CO-PLANARITY SHALL BE 0.1 MAX.
 2. PER REEL : 1000 CONNECTORS.
 3. AT THE BEGINNING OF THE REEL, 100 mm AT MIN SHALL BE EMPTY POCKETS.
 AT THE END OF THE REEL, 160 mm AT MIN SHALL BE EMPTY.
 4. CONTACT PLATING SPECIFICATIONS.
 CONTACT AREA : GOLD 0.05#m MIN.
 SMT LEAD : GOLD 0.05#m MIN.
 UNDERPLATING : NICKEL 1#m MIN.
 (SURFACE : SEALING)
 5. METAL HOLD DOWN PLATING SPECIFICATIONS.
 MOUNTING AREA: GOLD 0.05#m MIN.
 UNDERPLATING : NICKEL 1#m MIN.
 6. PEEL FORCE OF COVER TAPE REFERS TO JIS C 0806.

3	PHOSPHOR BRONZE	5	6	PS	PLASTIC REEL (BLACK)			
2	PHOSPHOR BRONZE	4	5	POLYESTER	CLEAR(COVER TAPE)			
1	LCP	UL94V-0, BLACK	4	PS	CLEAR(EMBOSSED CARRIER TAPE)			
NO.	MATERIAL	FINISH, REMARKS	NO.	MATERIAL	FINISH, REMARKS			
UNITS	mm	SCALE	FREE	COUNT	DESCRIPTION OF REVISIONS	DESIGNED	CHECKED	DATE
APPROVED : KH. IKEDA		09.01.19		DRAWING NO.		EDC3-308588-03		
CHECKED : TS. MIYAZAKI		09.01.19		PART NO.		DF37B-60DP-0.4V(53)		
DESIGNED : RT. SHIMIZU		09.01.17		CODE NO.		CL684-3013-1-53		
DRAWN : AK. AOYAGI		09.01.16						

Sep.1.2020 Copyright 2020 HIROSE ELECTRIC CO., LTD. All Rights Reserved.
 In case of consideration for using Automotive equipment / device which demand high reliability, kindly contact our sales window correspondents.

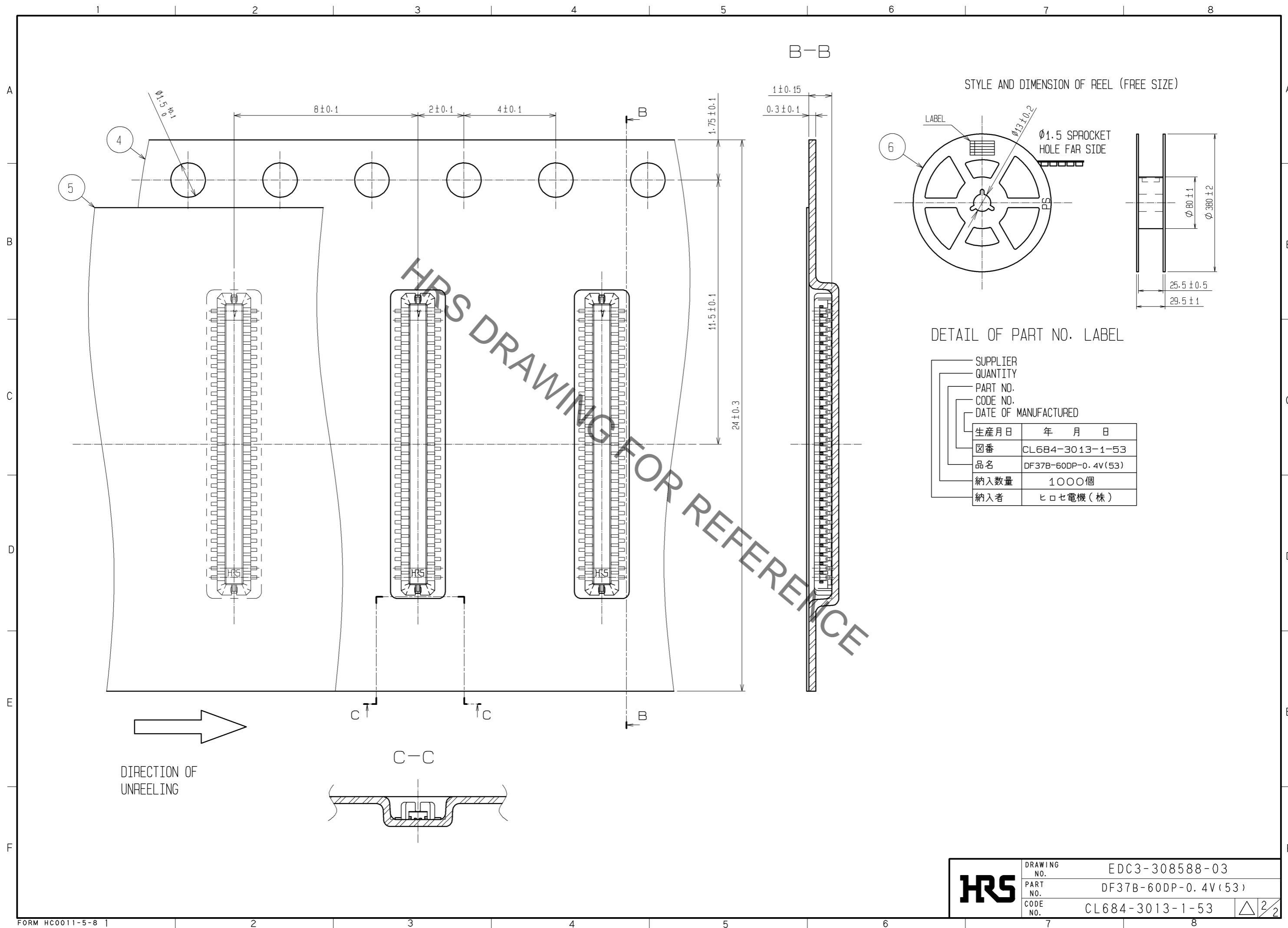

HRS	DRAWING NO.	EDC3-308588-03
	PART NO.	DF37B-60DP-0.4V(53)
	CODE NO.	CL684-3013-1-53
		△ 2/2