

PART NUMBER	REV	FIRST USED	POWER UNIT	FEED TYPE	DESCRIPTION
1852771-1	A	122500-1	LEADMAKER	POST FEED	CUTS CARRIER
1852771-2	A	565435-5	BENCH MODEL K	PRE FEED	CUTS CARRIER
1852771-3	A	354500-1	BENCH MODEL G	PRE FEED	CUTS CARRIER
1852771-6	A	122500-1	LEADMAKER	POST FEED	CONTINUOUS CARRIER
7-1852771-7	A	-	-	-	SPARE PARTS

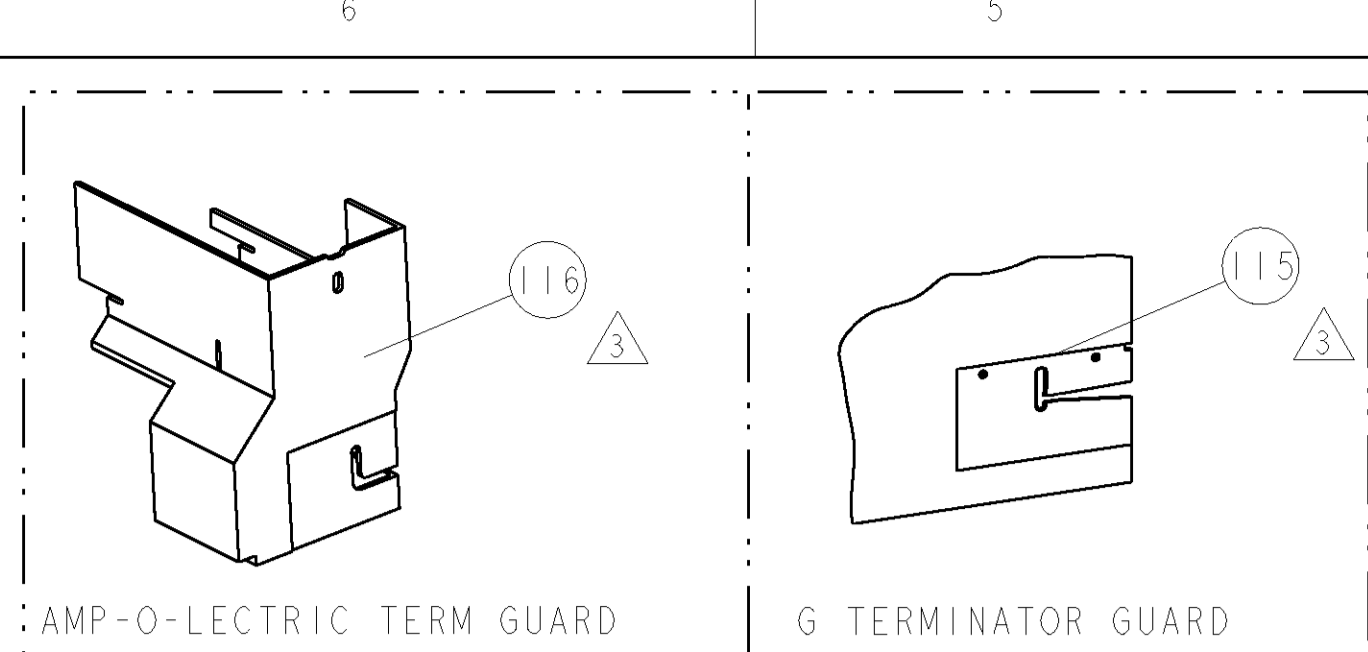

TERMINAL NAME: TAXI TERM LP SOC WGE BSA			
TE PN	DEL/P/PAK	DEL/P/PAK TERMINAL-DEL/P/PAK CRIMP SPECS	
1949809	12089134		
		PAD LTR	CRIMP HEIGHT
		A	1.65mm±.05/-0.05 [ .065±.002/-0.002 ]
		B	1.65mm±.05/-0.05 [ .065±.002/-0.002 ]
		C	-
		D	-
		CRIMP	SIZE
			TYPE
			RANGE
		WIRE	3.35mm [ .132 ]
		INSUL	4.95mm [ .195 ]
			F
			∅2.030 - 2.400
WIRE STRIP LENGTH	TERM APPL SPEC	FEED	APPLICATOR INSTRUCTIONS
4.72-5.49	PACKARD SPEC	13.97	408-8040
			SET UP GAGE
			458637-1

LOC	DIST	REVISIONS					
A	66	P	LTR	DESCRIPTION	DATE	DWN	APVD
		A		RELEASED	05DEC2008	MEH	TE
		A1		REV MISMATCH	09JAN2009	DM	DM

- △ RECOMMENDED SPARE PARTS
- △ GREASE LIGHTLY
- △ GUARD MUST BE IN PLACE WHEN OPERATING APPLICATOR IN A BENCH MACHINE

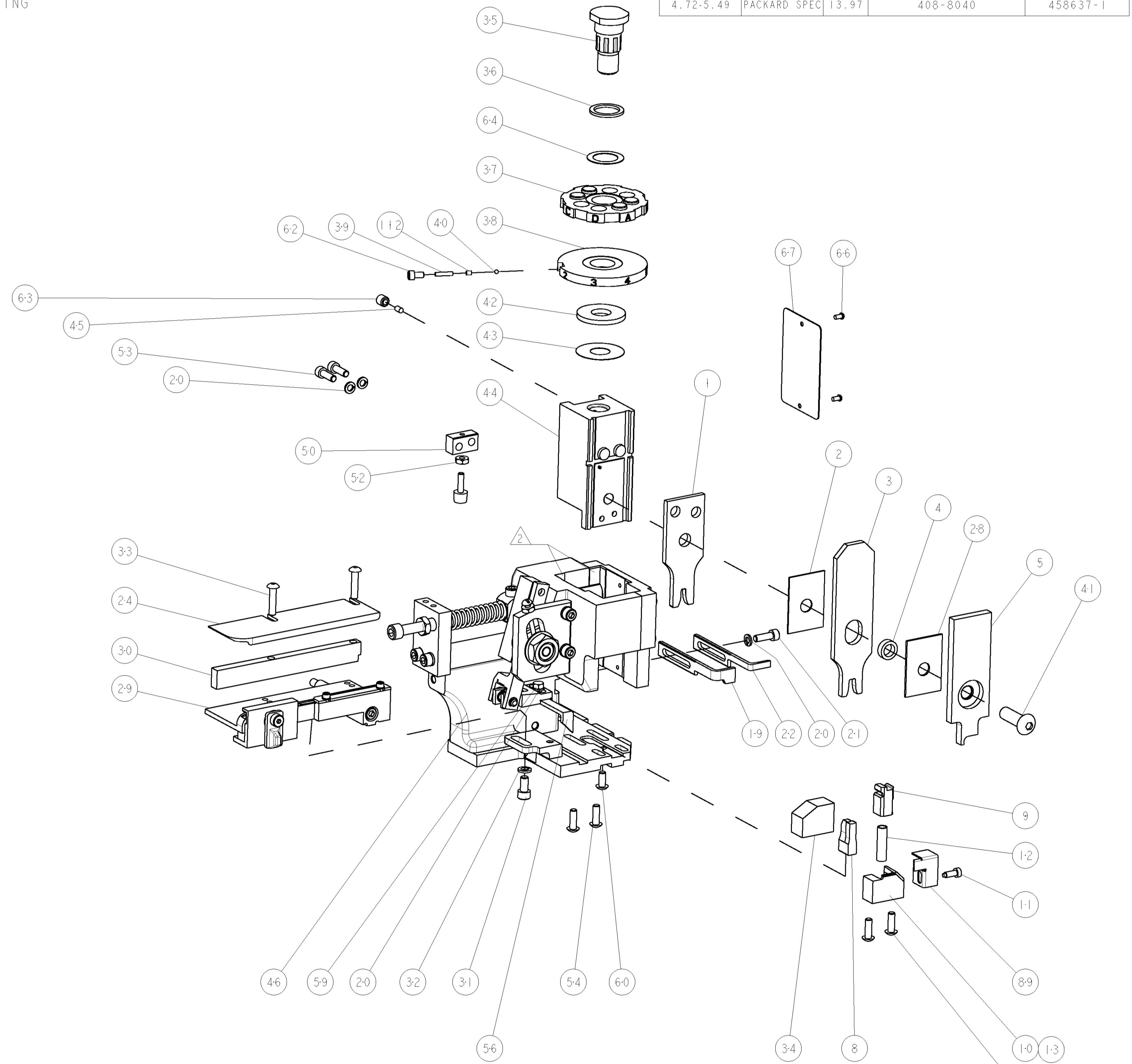
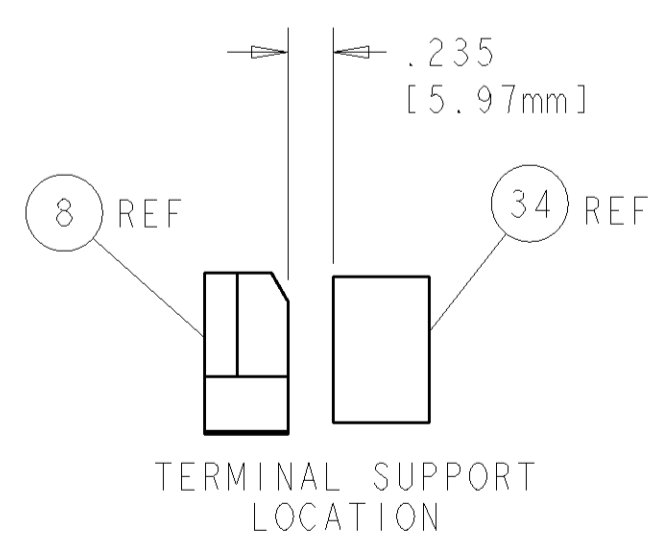
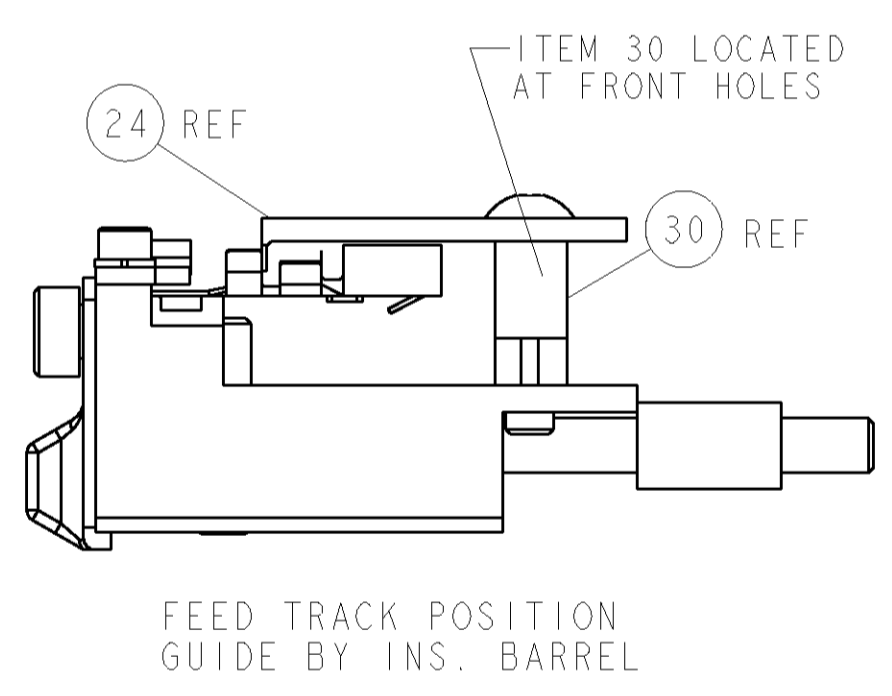
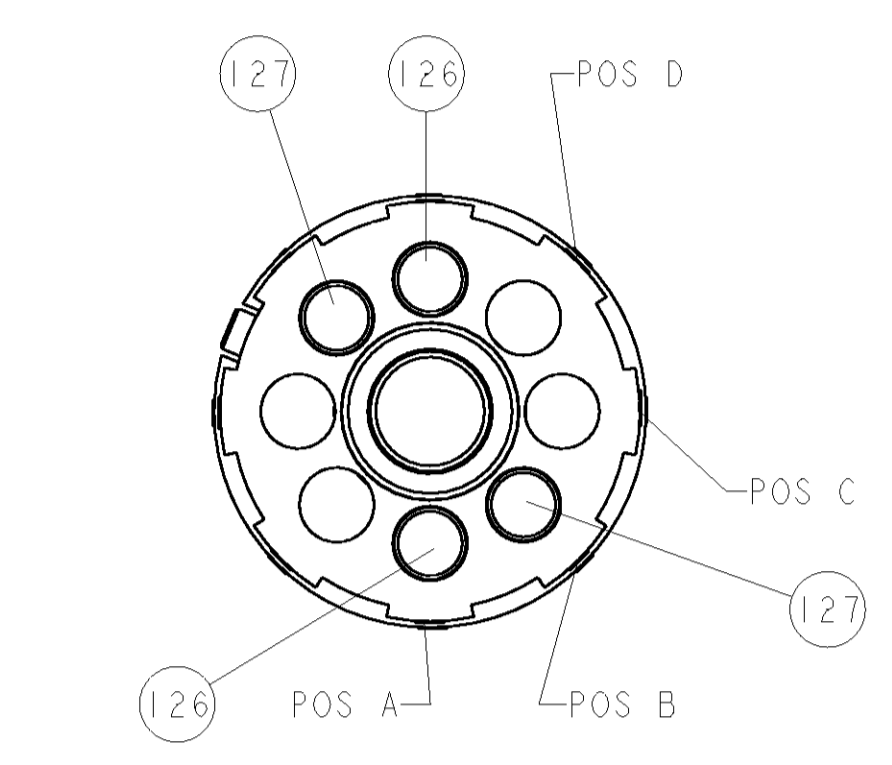

-	2	2	2	2	-	9-354778-5	PIN, WIRE DISC, .2970	127
-	2	2	2	2	-	1-354779-8	PIN, WIRE DISC, .3080	126
-	-	-	REF	-	..	455749-1	GUARD WINDOW	116
-	-	-	REF	-	..	679532-1	INSERT, GUARD	115
-	1	1	1	1	-	690603-1	SPRING ASSIST AMP-O-MATOR APPLICATOR	112
-	1	1	1	1	-	1-21002-7	SCR, BTN SKT HD CAP 6-32 X .375	91
-	1	1	1	1	-	318563-1	GUARD, FRONT CHIP	89
-	1	1	1	1	-	4088040	SF APPL INST 408-8040	72
-	1	1	1	1	-	217238-1	GENERAL INSTRUCTION PKG	71
-	1	1	1	1	-	461264-1	PLATE, IDENTIFICATION	67
-	2	2	2	2	-	21017-2	SCREW, DRIVE	66
-	1	1	1	1	-	986950-1	WASHER, FLAT PRECISION	64
-	1	1	1	1	-	21009-2	SCR, SET, SELF LOCKING 1/4-20 X .250	63
-	1	1	1	1	-	23030-1	SCR, SKT HD CAP 6-32 X .25	62
-	1	1	1	1	-	22733-8	SCR, BHSC, SELF-LOCKING, 8-32 X .375	60
-	1	1	1	1	-	2-22603-0	SCR, HEX HD CAP 8-32 X .312	59
-	1	1	1	1	-	458537-2	PAWL, FEED	56
-	4	4	4	4	-	2-21002-2	SCR, BTN SKT HD CAP 8-32 X .500	54
-	2	2	2	2	-	2-21000-7	SCR, SKT HD CAP 8-32 X .500	53
-	1	1	1	1	-	21018-5	NUT, HEX, REG 6-32	52
-	1	1	1	1	-	811242-8	BUMPER, HOLD DOWN	51
-	1	1	1	1	-	690753-1	SPACER, TONKER	50
-	-	-	-	-	..	690602-6	CAM, PRE FEED, 1 5/8	49
-	-	-	-	-	..	690602-5	CAM, PRE FEED, 1 1/8	48
-	1	-	-	1	-	690501-4	CAM, POST-FEED 1 5/8	47
-	1	1	1	1	-	459456-1	APPL. BASIC SUB ASSY (SIDE WISE MOCA)	46
-	1	1	1	1	-	690191-1	PLUG, NYLON	45
-	1	1	1	1	-	1-819307-3	RAM, SIDE FEED	44
-	1	1	1	1	-	690125-1	SHIM SUB-ASSY	43
-	1	1	1	1	-	690124-1	WASHER, RAM (.115)	42
-	1	1	1	1	-	7-21002-9	SCR, BTN SKT HD CAP 5/16-24 X 1.00	41
-	1	1	1	1	-	23241-6	BALL, STEEL	40
-	1	1	1	1	-	690170-1	SPRING, COMPRESSION	39
-	1	1	1	1	-	1-690142-0	DISC, INSULATION	38
-	1	1	1	1	-	354777-1	WIRE DISC, ASSEMBLY	37
-	1	1	1	1	-	22480-5	SPRING, COMPRESSION	36
-	1	1	1	1	-	690212-1	POST, RAM	35
-	1	1	1	1	-	690786-3	TERMINAL SUPPORT	34
-	2	2	2	2	-	2-21002-4	SCR, BTN SKT HD CAP 8-32 X .750	33
-	1	1	1	1	-	21024-5	WASHER, SPRG LOCK, REG NO 10	32
-	1	1	1	1	-	3-21000-4	SCR, SKT HD CAP 10-32 X .375	31
-	1	1	1	1	-	1320908-1	SPACER, STRIP GUIDE	30
-	1	1	1	1	-	1633091-1	ASSEMBLY, STRIP GUIDE	29
-	1	1	1	1	-	1-455888-0	SPACER, CRIMPER	28
-	1	1	1	1	-	1320928-1	PLATE, STRIP GUIDE	24
-	1	1	1	1	-	690472-2	STRIPPER	22
-	1	1	1	1	-	2-21000-7	SCR, SKT HD CAP 8-32 X .500	21
-	4	4	4	4	-	21024-4	WASHER, SPRG LOCK, REG NO 8	20
-	-	-	-	-	-	691353-1	STRIPPER	19
-	1	1	1	1	-	679625-1	SHEAR HOLDER, FRONT (NO CUT)	13
-	1	1	1	1	-	3-22280-3	SPRING, COMPRESSION	12
-	1	1	1	1	-	690461-1	STOP, SHEAR	11
-	-	-	-	-	-	690459-1	SHEAR HOLDER, FRONT	10
-	1	1	1	1	-	454276-1	FLOATING SHEAR, FRONT	9
-	1	1	1	1	-	1-1633566-1	ANVIL, COMBINATION	8
-	-	-	-	-	..	-	-	7
-	-	-	-	-	..	-	-	6
-	1	1	1	1	-	1-455889-4	DEPRESSOR, SHEAR	5
-	1	1	1	1	-	238011-1	BLOCK, CRIMPER SPACER	4
-	1	1	1	1	-	8-1633471-7	CRIMPER, INSULATION F	3
-	1	1	1	1	-	455888-6	SPACER, CRIMPER	2
-	1	1	1	1	-	2-1633609-3	CRIMPER, WIRE	1

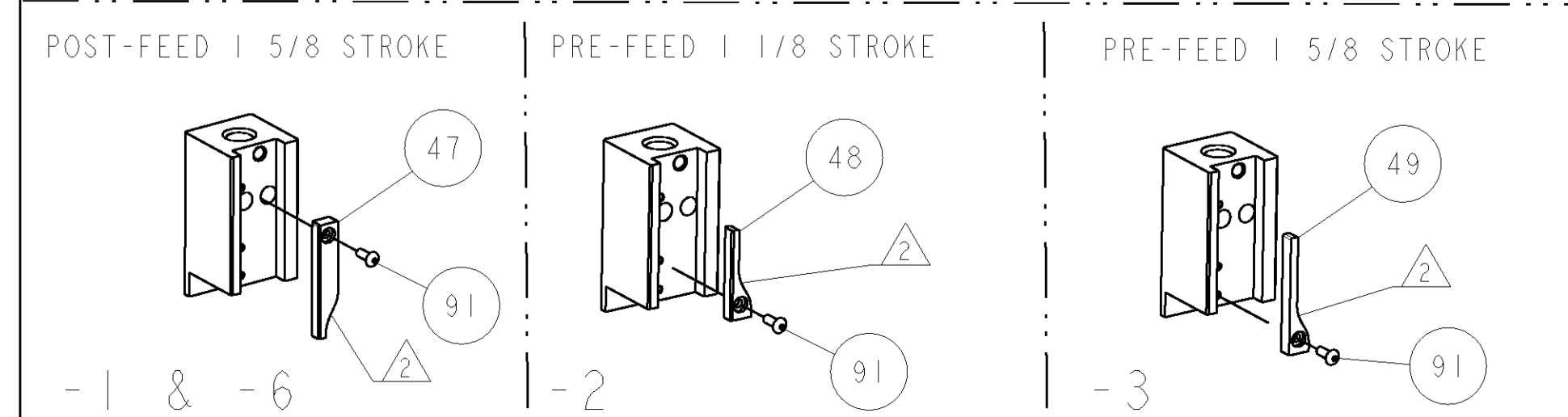

DIMENSIONS:		TOLERANCES UNLESS OTHERWISE SPECIFIED:		MATERIAL:		FINISH:	
INCHES		9 PLC	±.001	WIRE			
		1 PLC	±.001				
		3 PLC	±.001				
		4 PLC	±.001				
		ANGLES	±.0001				

APVD	DM HERR	04NOV2008	Tyco Electronics Harrisburg, PA 17105-3608
CHK	G. BAILEY	05NOV2008	
NAME	SIDE FEED HDM APPLICATOR		
PRODUCT SPEC	-		
APPLICATION SPEC	-		
SIZE	CAGE CODE	DRAWING NO	RESTRICTED TO
A1	00779	C=1852771	-
CUSTOMER DRAWING	SCALE	SHEET	OF
	3:5	1	REV A1

CUSTOMER VIEWABLE ASSEMBLY

# Mouser Electronics

Authorized Distributor

Click to View Pricing, Inventory, Delivery & Lifecycle Information:

[TE Connectivity:](#)

[1852771-3](#)