

THIS DRAWING IS UNPUBLISHED. RELEASED FOR PUBLICATION  
 © COPYRIGHT - By - ALL RIGHTS RESERVED.

REVISIONS				
P	LTR	DESCRIPTION	DATE	APVD
AM2		REVISED PER ECO-16-014786	19OCT2016	RS MZ

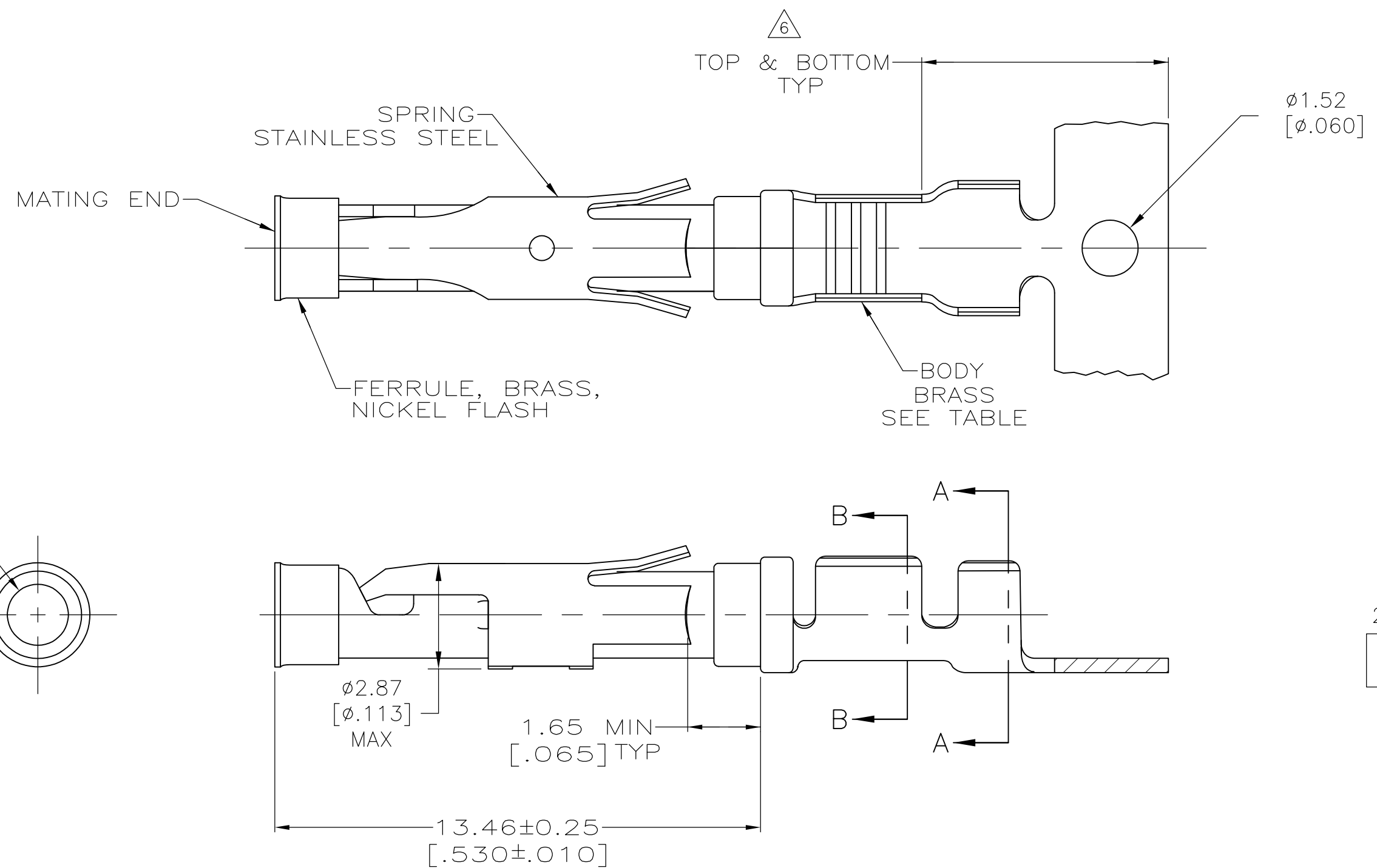

$\Delta 1.27\mu\text{m} [0.00050]$  MIN TIN PER MIL-T-10727 OVER  
 $0.76\mu\text{m} [0.00030]$  MIN NICKEL PER QQ-N-290.

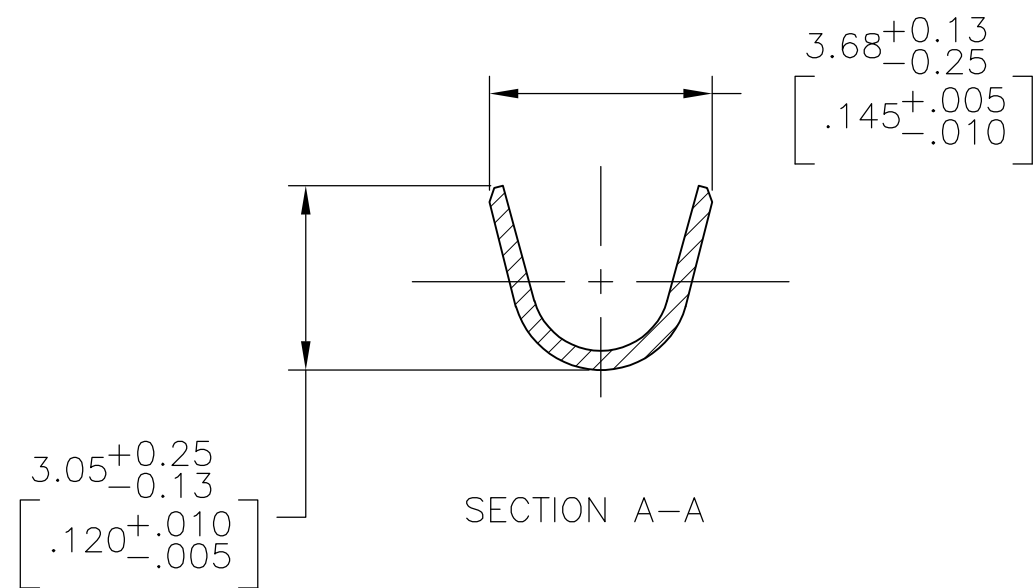
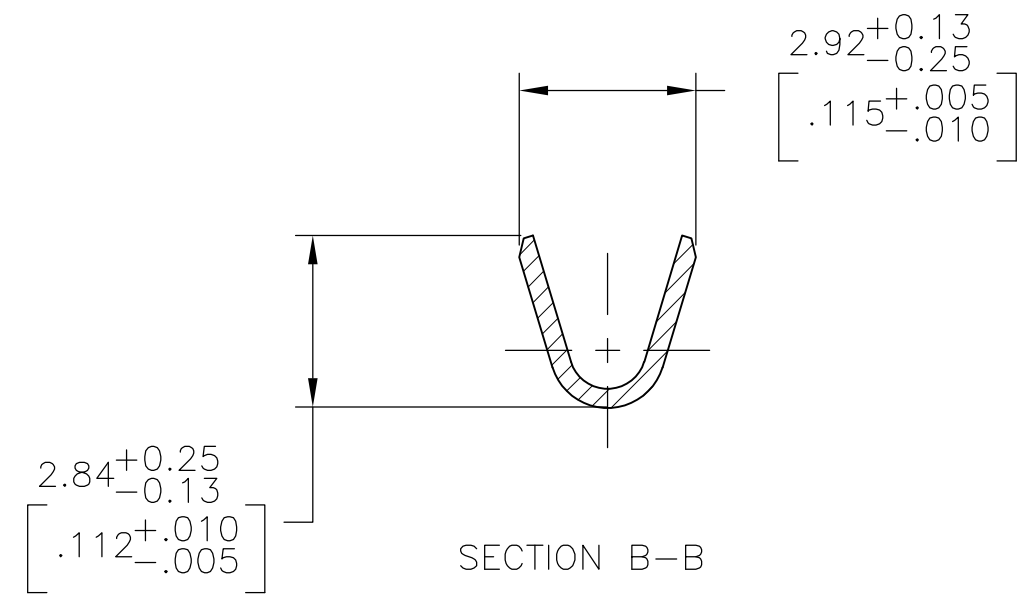
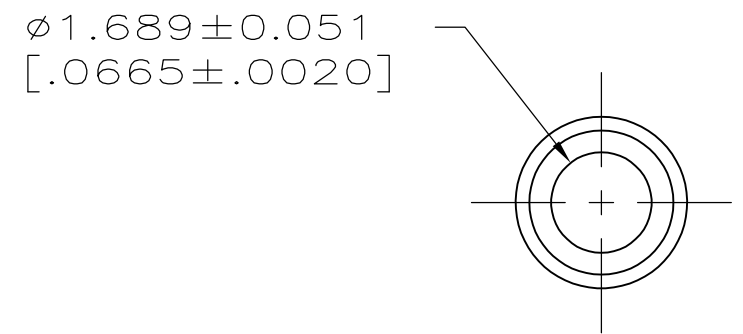

- $\Delta 1$   $0.76\mu\text{m} [0.00030]$  MIN GOLD PER MIL-G-45204 ON MATING END FOR A LENGTH OF 5.08 [.200] MIN WITH  $1.27\mu\text{m} [0.00050]$  MIN MATTE TIN PLATE IN WIRE CRIMP AREA, BOTH OVER  $0.76\mu\text{m} [0.00030]$  MIN NICKEL PER QQ-N-290.
- $\Delta 2$   $1.27\mu\text{m} [0.00050]$  MIN TIN-LEAD PER MIL-T-10727 OVER  $0.76\mu\text{m} [0.00030]$  MIN NICKEL PER QQ-N-290.
- $\Delta 3$   $0.76\mu\text{m} [0.00030]$  MIN GOLD PER MIL-G-45204 ON MATING END FOR A LENGTH OF 5.08 [.200] MIN WITH A UNIFORM GRADIENT TO  $0.25\mu\text{m} [0.00010]$  MIN GOLD PER MIL-G-45204 ON THE REMAINDER OVER  $0.76\mu\text{m} [0.00030]$  MIN NICKEL PER QQ-N-290.
- $\Delta 4$   $0.38\mu\text{m} [0.00015]$  MIN GOLD PER MIL-G-45204 ON MATING END FOR A LENGTH OF 5.08 [.200] MIN WITH  $1.27\mu\text{m} [0.00050]$  MIN MATTE TIN PLATE IN WIRE CRIMP AREA, BOTH OVER  $0.76\mu\text{m} [0.00030]$  MIN NICKEL PER QQ-N-290.
- $\Delta 5$   $1.27\mu\text{m} [0.00050]$  MIN GOLD PER MIL-G-45204 ON MATING END FOR A LENGTH OF 5.08 [.200] MIN WITH GOLD FLASH ON REMAINDER OVER  $1.90\mu\text{m} [0.00075]$  MIN NICKEL PER QQ-N-290.
- $\Delta 6$  GOLD PLATING NEED NOT APPEAR IN THIS AREA EXCEPT 1-66100-3 HAS GOLD PLATING ON INSULATION BARREL.
- $\Delta 7$  REVERSE REELED FOR MINI-APPLICATOR.
- 8 ALL PART NUMBERS ON THIS DRAWING HAVE APPLICATION TOOLING AVAILABLE TO CRIMP 18-16 WIRE AWG WITH AN INSULATION RANGE OF  $\phi 2.03-2.54 [0.080-.100]$ . ADDITIONALLY, LOOSE PIECE AND REVERSE REELED PART NUMBERS HAVE APPLICATION TOOLING AVAILABLE TO CRIMP  $0.75\text{mm}^2$  WIRE WITH AN INSULATION RANGE OF  $\phi 1.35-1.65 [0.053-.065]$  OR  $1.0\text{mm}^2$  WIRE WITH AN INSULATION RANGE OF  $\phi 1.45-1.80 [0.057-.071]$ .
- $\Delta 9$   $0.38\mu\text{m} [0.00015]$  MIN GOLD PER MIL-G-45204 ON MATING END FOR A LENGTH OF 5.08 [.200] MIN,  $1.27\mu\text{m} [0.00050]$  MIN TIN-LEAD PER MIL-T-10727 FOR A LENGTH OF 5.69 [.224] MIN ON OPPOSITE END, BOTH OVER  $1.27\mu\text{m} [0.00050]$  MIN NICKEL PER QQ-N-290 ON ENTIRE CONTACT.

SUPERCEDED BY 66100-8

OBSOLETE	EUROPE	$\Delta 7$	$\Delta 10$	NONE	—2-66100-2—
OBSOLETE		$\Delta 7$	$\Delta 1$	NONE	—2-66100-1—
		STANDARD	$\Delta 10$	1-66101-9	2-66100-0
		$\Delta 7$	$\Delta 10$	1-66101-9	1-66100-9
		$\Delta 7$	$\Delta 9$	1-66101-4	—1-66100-7—
			$\Delta 5$	—	—1-66100-3—
		$\Delta 7$	$\Delta 1$	66101-4	66100-9
		$\Delta 7$	$\Delta 4$	66101-3	66100-8
		$\Delta 7$	$\Delta 2$	66101-2	66100-7
		$\Delta 7$	$\Delta 3$	66101-1	66100-6
		STANDARD	$\Delta 1$	66101-4	66100-4
		STANDARD	$\Delta 4$	66101-3	66100-3
		STANDARD	$\Delta 2$	66101-2	66100-2
		STANDARD	$\Delta 3$	66101-1	66100-1
	TE ASSEMBLY LOCATION	REELING	BODY FINISH	LOOSE PIECE REF	PART NO.

THIS DRAWING IS A CONTROLLED DOCUMENT.

DIMENSIONS: mm [INCHES]	TOLERANCES UNLESS OTHERWISE SPECIFIED:	DWN V. FURLER 11JUL03	
	0 PLC ± -	CHK G. STEINHAEUER 11JUL03	
	1 PLC ± -	APVD G. STEINHAEUER 11JUL03	
	2 PLC ± 0.13 [.005]	PRODUCT SPEC	
MATERIAL SEE CALLOUTS	FINISH SEE CALLOUTS	APPLICATION SPEC	NAME SOCKET ASSEMBLY, .062, TYPE III+
		WEIGHT	SIZE A2
		CUSTOMER DRAWING	CAGE CODE 00779
			DRAWING NO C=66100
			RESTRICTED TO —
			SCALE 8:1
			SHEET 1 of 1
			REV AM2

# Mouser Electronics

Authorized Distributor

Click to View Pricing, Inventory, Delivery & Lifecycle Information:

[TE Connectivity:](#)

[2-66100-0](#)