

DO NOT SCALE

METRIC

THIRD ANGLE  
PROJECTION



DIMENSIONS IN mm

REVISION

LTR	DESCRIPTION	DATE	DWN	APVD
K2	ECR-17-017018	07JUL2018	DT	TD

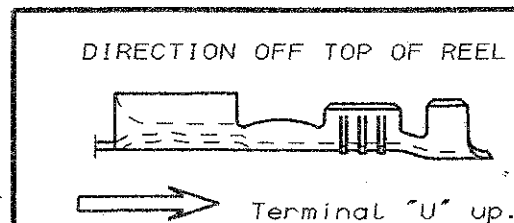
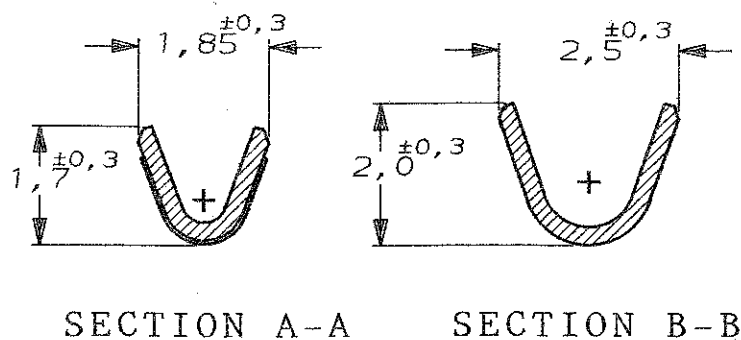
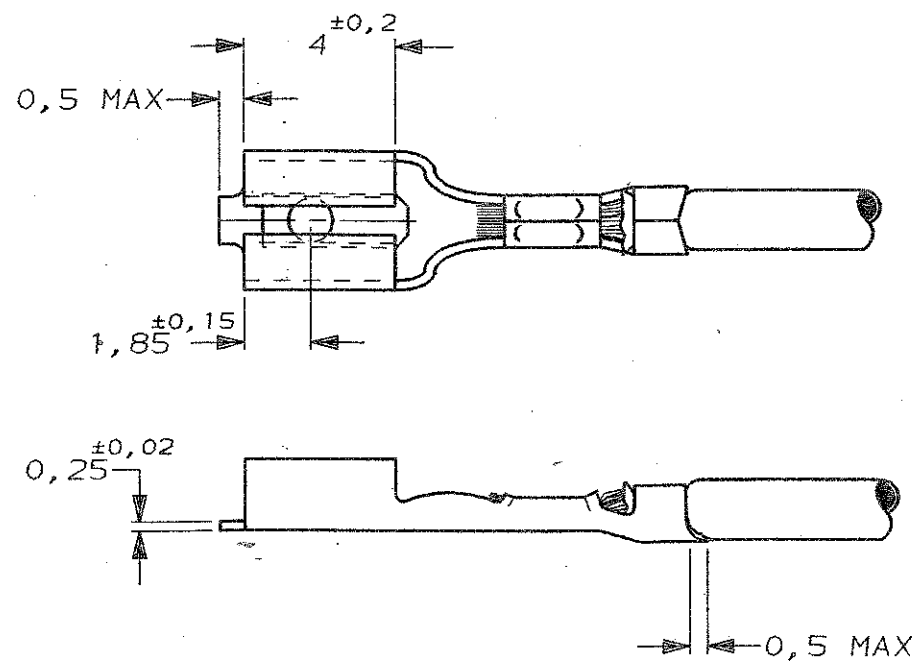
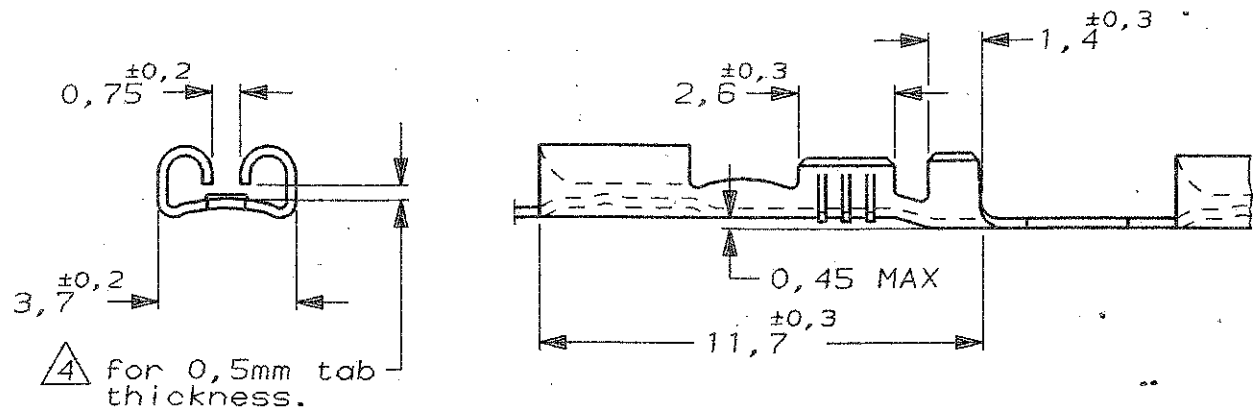
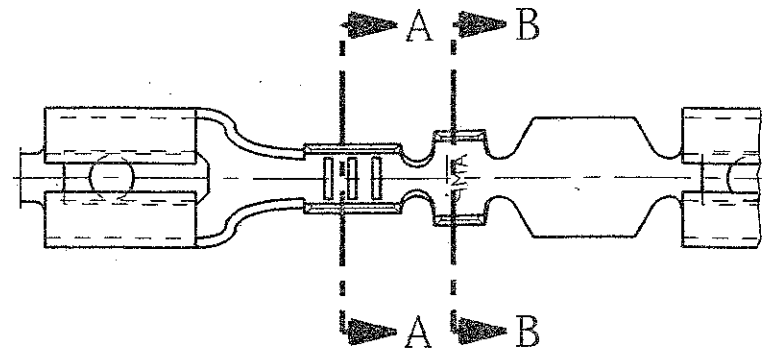

NOTES

- △1 FOR USE ON MINIATURE APPLICATORS ( LEFT-RIGHT FEED ) AND STANDARD APPLICATORS ( RIGHT-LEFT FEED ).
- △2 BRASS ACC ASTM B36 ALLOY 260.
- △3 PH.BRONZE ACC ASTM B103.
- △4 GAGE 0,45 MUST NOT ENTER , GAGE 0,33 MUST ENTER.
- △5 OBSOLETE PARTS: OBSOLETE CIS STREAMLINING PER D.RENAUD/D.SINISI

NOTES	FINISH	MATERIAL	PARTNUMBER
△1 △2	TINPLATED	BRASS	160666-5
△1 △3	TINPLATED	PH.BRONZE	<del>160666-4</del>
△1 △2	UNPLATED	BRASS	<del>160666-3</del>
△1 △3	GOLDPLATED	PH.BRONZE	<del>160666-2</del>
△1 △3	UNPLATED	PH.BRONZE	160666-1

**CUSTOMER DRAWING**

FOR REFERENCE ONLY  
WILL NOT BE UPDATED

**AMP** | AMP-HOLLAND B.V.  
's-Hertogenbosch, The Netherlands.

THIS DRAWING IS UNPUBLISHED RELEASED FOR PUBLICATION oct , 1986

© COPYRIGHT 1986 BY AMP-HOLLAND B.V.  
ALL INTERNATIONAL RIGHTS RESERVED.  
AMP PRODUCTS MAY BE COVERED BY U.S. AND FOREIGN PATENTS AND/OR PATENTS PENDING.

DR.	DATE	WIRE RANGE	NAME	REV. DATE
R.v.Lokven	06.10.86	0,12-0,35mm <sup>2</sup>	.110 SRS FASTON RECEPTACLE. ( short version ).	D M Y
CHK. A.B.	07.10.86	INSUL. RANGE 0,9-1,6mmDIA		06 10 86
APP. L.v.Soest	07.10.86	SIZE A3	SHEET 1 OF 1	REV.LTR. K2

8 | 7 | 6 | 5 | 4 | 3 | 2 | 1