



Is Now Part of



**ON Semiconductor®**

To learn more about ON Semiconductor, please visit our website at  
[www.onsemi.com](http://www.onsemi.com)

Please note: As part of the Fairchild Semiconductor integration, some of the Fairchild orderable part numbers will need to change in order to meet ON Semiconductor's system requirements. Since the ON Semiconductor product management systems do not have the ability to manage part nomenclature that utilizes an underscore (\_), the underscore (\_) in the Fairchild part numbers will be changed to a dash (-). This document may contain device numbers with an underscore (\_). Please check the ON Semiconductor website to verify the updated device numbers. The most current and up-to-date ordering information can be found at [www.onsemi.com](http://www.onsemi.com). Please email any questions regarding the system integration to [Fairchild\\_questions@onsemi.com](mailto:Fairchild_questions@onsemi.com).

ON Semiconductor and the ON Semiconductor logo are trademarks of Semiconductor Components Industries, LLC dba ON Semiconductor or its subsidiaries in the United States and/or other countries. ON Semiconductor owns the rights to a number of patents, trademarks, copyrights, trade secrets, and other intellectual property. A listing of ON Semiconductor's product/patent coverage may be accessed at [www.onsemi.com/site/pdf/Patent-Marking.pdf](http://www.onsemi.com/site/pdf/Patent-Marking.pdf). ON Semiconductor reserves the right to make changes without further notice to any products herein. ON Semiconductor makes no warranty, representation or guarantee regarding the suitability of its products for any particular purpose, nor does ON Semiconductor assume any liability arising out of the application or use of any product or circuit, and specifically disclaims any and all liability, including without limitation special, consequential or incidental damages. Buyer is responsible for its products and applications using ON Semiconductor products, including compliance with all laws, regulations and safety requirements or standards, regardless of any support or applications information provided by ON Semiconductor. "Typical" parameters which may be provided in ON Semiconductor data sheets and/or specifications can and do vary in different applications and actual performance may vary over time. All operating parameters, including "Typicals" must be validated for each customer application by customer's technical experts. ON Semiconductor does not convey any license under its patent rights nor the rights of others. ON Semiconductor products are not designed, intended, or authorized for use as a critical component in life support systems or any FDA Class 3 medical devices or medical devices with a same or similar classification in a foreign jurisdiction or any devices intended for implantation in the human body. Should Buyer purchase or use ON Semiconductor products for any such unintended or unauthorized application, Buyer shall indemnify and hold ON Semiconductor and its officers, employees, subsidiaries, affiliates, and distributors harmless against all claims, costs, damages, and expenses, and reasonable attorney fees arising out of, directly or indirectly, any claim of personal injury or death associated with such unintended or unauthorized use, even if such claim alleges that ON Semiconductor was negligent regarding the design or manufacture of the part. ON Semiconductor is an Equal Opportunity/Affirmative Action Employer. This literature is subject to all applicable copyright laws and is not for resale in any manner.

# FAN7621S

## PFM Controller for Half-Bridge Resonant Converters

### Features

- Variable Frequency Control with 50% Duty Cycle for Half-bridge Resonant Converter Topology
- High Efficiency through Zero Voltage Switching (ZVS)
- Fixed Dead Time: 350ns
- Up to 300kHz Operating Frequency
- Auto-Restart Operation for All Protections with an External LV<sub>CC</sub>
- Protection Functions: Over-Voltage Protection (OVP), Over-Current Protection (OCP), Abnormal Over-Current Protection (AOCP), Internal Thermal Shutdown (TSD)

### Applications

- PDP and LCD TVs
- Desktop PCs and Servers
- Adapters
- Telecom Power Supplies
- Video Game Consoles

### Description

The FAN7621S is a pulse frequency modulation controller for high-efficiency half-bridge resonant converters. Offering everything necessary to build a reliable and robust resonant converter, the FAN7621S simplifies designs and improves productivity, while improving performance. The FAN7621S includes a high-side gate-drive circuit, an accurate current-controlled oscillator, frequency-limit circuit, soft-start, and built-in protection functions. The high-side gate-drive circuit has a common-mode noise cancellation capability, which guarantees stable operation with excellent noise immunity. Using the zero-voltage-switching (ZVS) technique dramatically reduces the switching losses and significantly improves efficiency. The ZVS also reduces the switching noise noticeably, which allows a small-sized Electromagnetic Interference (EMI) filter.

The FAN7621S can be applied to various resonant converter topologies; such as series resonant, parallel resonant, and LLC resonant converters.

### Related Resources

[AN4151 — Half-Bridge LLC Resonant Converter Design Using FSFR-Series Fairchild Power Switch \(FPS™\)](#)

### Ordering Information

Part Number	Operating Junction Temperature	Package	Packaging Method
FAN7621SSJ	-40°C to +130°C	16-Lead, Small Outline Package (SOP)	Tube
FAN7621SSJX			Tape & Reel

### Application Circuit Diagram

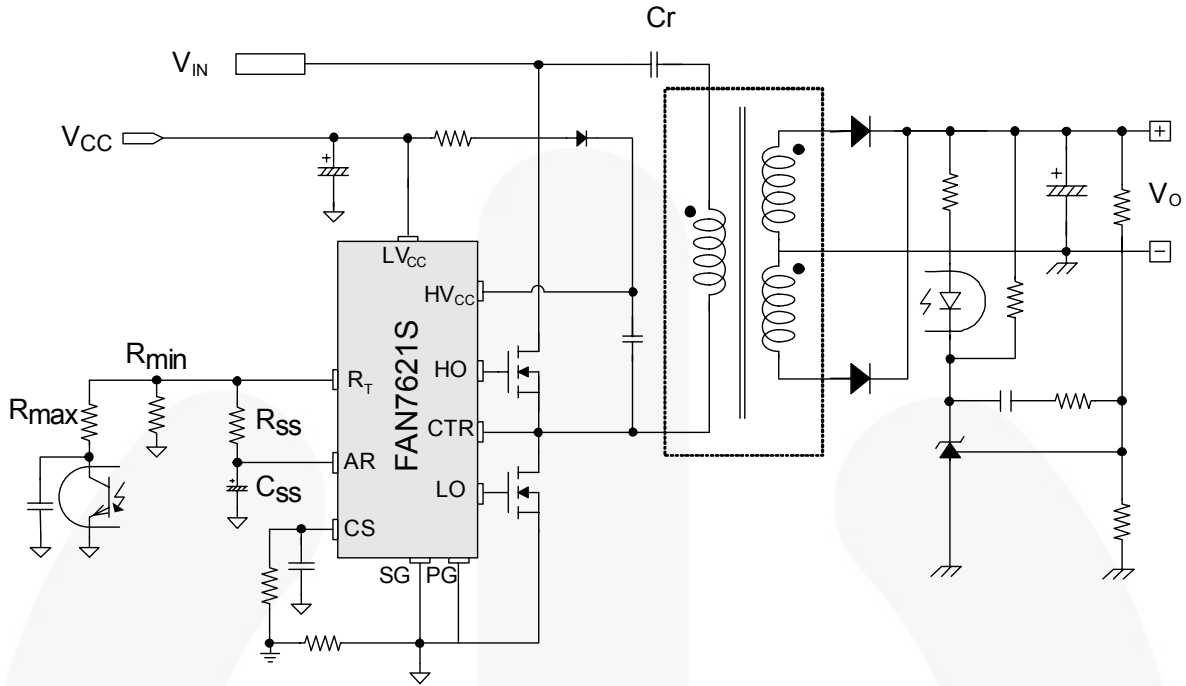

Figure 1. Typical Application Circuit (LLC Resonant Half-Bridge Converter)

### Block Diagram

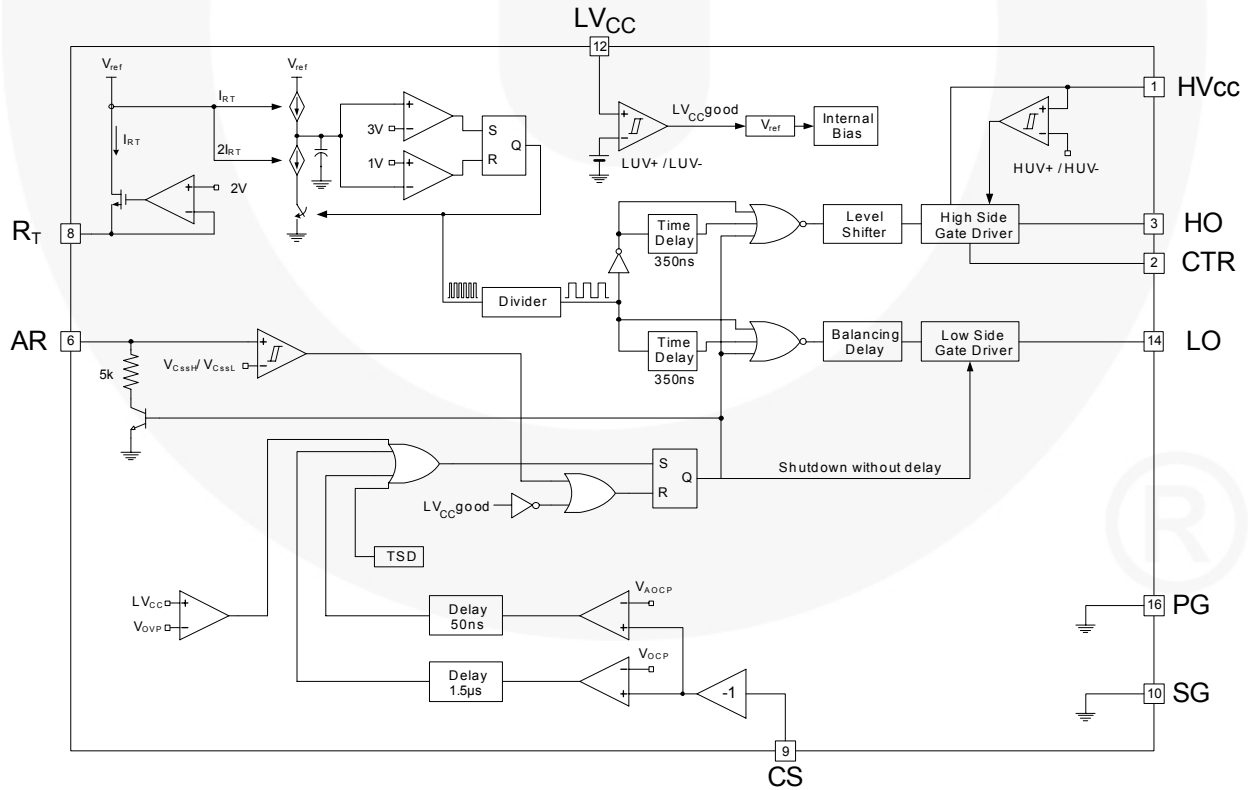

Figure 2. Internal Block Diagram

## Pin Configuration

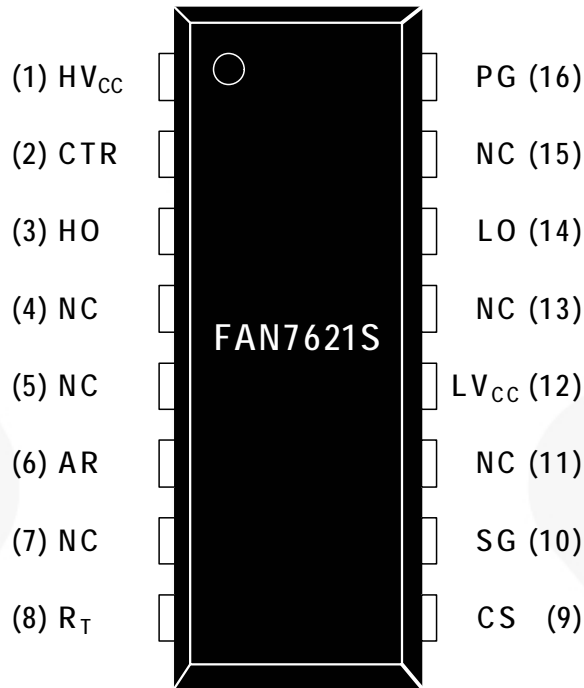

Figure 3. Package Diagram

## Pin Definitions

Pin #	Name	Description
1	HV <sub>CC</sub>	This is the supply voltage of the high-side gate-drive circuit IC.
2	CTR	This is the drain of the low-side MOSFET. Typically, a transformer is connected to this pin.
3	HO	This is the high-side gate driving signal.
4	NC	No connection
5	NC	No connection
6	AR	This pin is for discharging the external soft-start capacitor when any protection is triggered. When the voltage of this pin drops to 0.2V, all protections are reset and the controller starts to operate again.
7	NC	No connection
8	R <sub>T</sub>	This pin programs the switching frequency. Typically, an opto-coupler is connected to control the switching frequency for the output voltage regulation.
9	CS	This pin senses the current flowing through the low-side MOSFET. Typically, negative voltage is applied on this pin.
10	SG	This pin is the control ground.
11	NC	No connection
12	LV <sub>CC</sub>	This pin is the supply voltage of the control IC.
13	NC	No connection
14	LO	This is the low-side gate driving signal.
15	NC	No connection
16	PG	This pin is the power ground. This pin is connected to the source of the low-side MOSFET.

## Absolute Maximum Ratings

Stresses exceeding the absolute maximum ratings may damage the device. The device may not function or be operable above the recommended operating conditions and stressing the parts to these levels is not recommended. In addition, extended exposure to stresses above the recommended operating conditions may affect device reliability. The absolute maximum ratings are stress ratings only.  $T_A=25^{\circ}\text{C}$  unless otherwise specified.

Symbol	Parameter	Min.	Max.	Unit
$V_{HO}$	High-Side Gate Driving Voltage	$V_{CTR}-0.3$	$HV_{CC}$	V
$V_{LO}$	Low-Side Gate Driving Voltage	-0.3	$LV_{CC}$	
$LV_{CC}$	Low-Side Supply Voltage	-0.3	25.0	V
$HV_{CC}$ to $V_{CTR}$	High-Side $V_{CC}$ Pin to Center Voltage	-0.3	25.0	V
$V_{CTR}$	Center Voltage	-0.3	600.0	V
$V_{AR}$	Auto-Restart Pin Input Voltage	-0.3	$LV_{CC}$	V
$V_{CS}$	Current Sense (CS) Pin Input Voltage	-5.0	1.0	V
$V_{RT}$	$R_T$ Pin Input Voltage	-0.3	5.0	V
$dV_{CTR}/dt$	Allowable Center Voltage Slew Rate		50	V/ns
$P_D$	Total Power Dissipation		1.13	W
$T_J$	Maximum Junction Temperature <sup>(1)</sup>		+150	°C
	Recommended Operating Junction Temperature <sup>(1)</sup>	-40	+130	
$T_{STG}$	Storage Temperature Range	-55	+150	°C

### Note:

- The maximum value of the recommended operating junction temperature is limited by thermal shutdown.

## Thermal Impedance

Symbol	Parameter	Value	Unit
$\theta_{JA}$	Junction-to-Ambient Thermal Impedance	110	°C/W

## Electrical Characteristics

$T_A=25^\circ\text{C}$  and  $LV_{CC}=17\text{V}$  unless otherwise specified.

Symbol	Parameter	Test Conditions	Min.	Typ.	Max.	Unit
<b>Supply Section</b>						
$I_{LK}$	Offset Supply Leakage Current	$HV_{CC}=V_{CTR}$			50	$\mu\text{A}$
$I_{QH_{VCC}}$	Quiescent $HV_{CC}$ Supply Current	$(HV_{CC}UV+) - 0.1\text{V}$		50	120	$\mu\text{A}$
$I_{QL_{VCC}}$	Quiescent $LV_{CC}$ Supply Current	$(LV_{CC}UV+) - 0.1\text{V}$		100	200	$\mu\text{A}$
$I_{OH_{VCC}}$	Operating $HV_{CC}$ Supply Current (RMS Value)	$f_{OSC}=100\text{kHz}$ , $C_{Load}=1\text{nF}$		5	8	$\text{mA}$
		No Switching		100	200	$\mu\text{A}$
$I_{OL_{VCC}}$	Operating $LV_{CC}$ Supply Current (RMS Value)	$f_{OSC}=100\text{kHz}$ , $C_{Load}=1\text{nF}$		6	9	$\text{mA}$
		No Switching		2	4	$\text{mA}$
<b>UVLO Section</b>						
$LV_{CC}UV+$	$LV_{CC}$ Supply Under-Voltage Positive-Going Threshold ( $LV_{CC}$ Start)		11.2	12.5	13.8	V
$LV_{CC}UV-$	$LV_{CC}$ Supply Under-Voltage Negative-Going Threshold ( $LV_{CC}$ Stop)		8.9	10.0	11.1	V
$LV_{CC}UVH$	$LV_{CC}$ Supply Under-Voltage Hysteresis			2.5		V
$HV_{CC}UV+$	$HV_{CC}$ Supply Under-Voltage Positive-Going Threshold ( $HV_{CC}$ Start)		8.2	9.2	10.2	V
$HV_{CC}UV-$	$HV_{CC}$ Supply Under-Voltage Negative-Going Threshold ( $HV_{CC}$ Stop)		7.8	8.7	9.6	V
$HV_{CC}UVH$	$HV_{CC}$ Supply Under-Voltage Hysteresis			0.5		V
<b>Oscillator &amp; Feedback Section</b>						
$V_{RT}$	V-I Converter Threshold Voltage	$R_T=5.2\text{k}\Omega$	1.5	2.0	2.5	V
$f_{OSC}$	Output Oscillation Frequency		94	100	106	$\text{kHz}$
DC	Output Duty Cycle		48	50	52	%
$f_{SS}$	Internal Soft-Start Initial Frequency	$f_{SS}=f_{OSC}+40\text{kHz}$ , $R_T=5.2\text{k}\Omega$		140		$\text{kHz}$
$t_{SS}$	Internal Soft-Start Time		2	3	4	ms
<b>Output Section</b>						
$I_{source}$	Peak Sourcing Current	$HV_{CC}=17\text{V}$	250	360		$\text{mA}$
$I_{sink}$	Peak Sinking Current	$HV_{CC}=17\text{V}$	460	600		$\text{mA}$
$t_r$	Rising Time	$C_{Load}=1\text{nF}$ , $HV_{CC}=17\text{V}$		65		ns
$t_f$	Falling Time				35	
$V_{HOH}$	High Level of High-Side Gate Driving Signal ( $V_{HVCC}-V_{HO}$ )	$I_O=20\text{mA}$			1.0	V
$V_{HOL}$	Low Level of High-Side Gate Driving Signal				0.6	V
$V_{LOH}$	High Level of High-Side Gate Driving Signal ( $V_{LVCC}-V_{LO}$ )				1.0	V
$V_{LOL}$	Low Level of High-Side Gate Driving Signal				0.6	V

**Electrical Characteristics** (Continued)T<sub>A</sub>=25°C and LV<sub>CC</sub>=17V unless otherwise specified.

Symbol	Parameter	Test Conditions	Min.	Typ.	Max.	Unit
<b>Protection Section</b>						
V <sub>CSSH</sub>	Beginning Voltage to Discharge C <sub>SS</sub>		0.9	1.0	1.1	V
V <sub>CSSL</sub>	Beginning Voltage to Charge C <sub>SS</sub> and Reset Protections		0.16	0.20	0.24	V
V <sub>OVP</sub>	LV <sub>CC</sub> Over-Voltage Protection	LV <sub>CC</sub> > 21V	21	23	25	V
V <sub>AOCP</sub>	AOCP Threshold Voltage	ΔV/Δt=-0.1V/μs	-1.0	-0.9	-0.8	V
t <sub>BAO</sub>	AOCP Blanking Time <sup>(2)</sup>	V <sub>CS</sub> < V <sub>AOCP</sub> ; ΔV/Δt=-0.1V/μs		50		ns
V <sub>OCP</sub>	OCP Threshold Voltage	ΔV/Δt=-1V/μs	-0.64	-0.58	-0.52	V
t <sub>BO</sub>	OCP Blanking Time <sup>(2)</sup>	V <sub>CS</sub> < V <sub>OCP</sub> ; ΔV/Δt=-1V/μs	1.0	1.5	2.0	μs
t <sub>DA</sub>	Delay Time (Low-Side) Detecting from V <sub>AOCP</sub> to Switch Off <sup>(2)</sup>	ΔV/Δt=-1V/μs		250	400	ns
T <sub>SD</sub>	Thermal Shutdown Temperature <sup>(2)</sup>		110	130	150	°C
<b>Dead-Time Control Section</b>						
D <sub>T</sub>	Dead Time <sup>(3)</sup>			350		ns

**Notes:**

- These parameters, although guaranteed, are not tested in production.
- These parameters, although guaranteed, are tested only in EDS (wafer test) process.

## Typical Performance Characteristics

These characteristic graphs are normalized at  $T_A=25^{\circ}\text{C}$ .

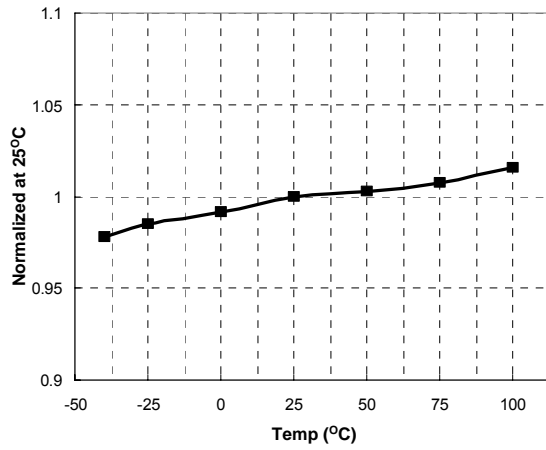

**Figure 4. Low-Side MOSFET Duty Cycle vs. Temperature**

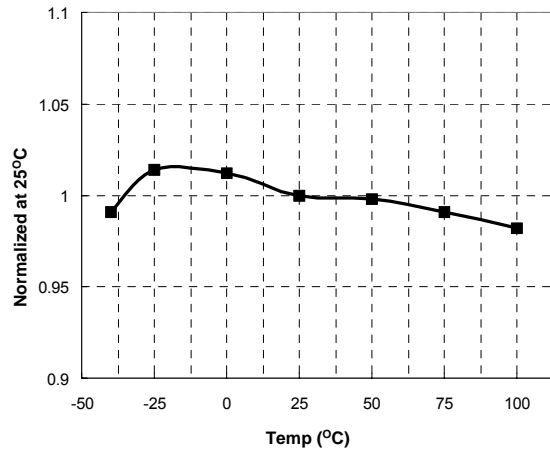

**Figure 5. Switching Frequency vs. Temperature**

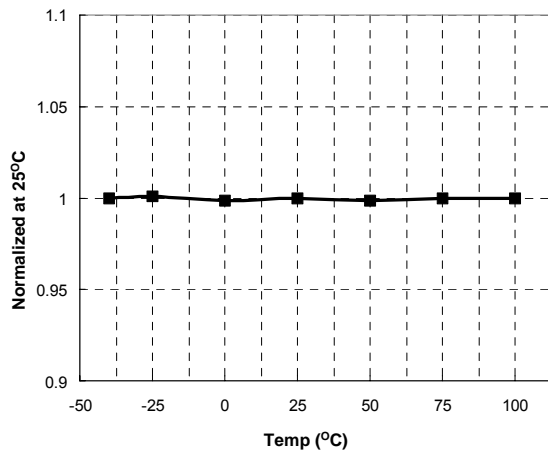

**Figure 6. High-Side  $V_{CC}$  ( $HV_{CC}$ ) Start vs. Temperature**

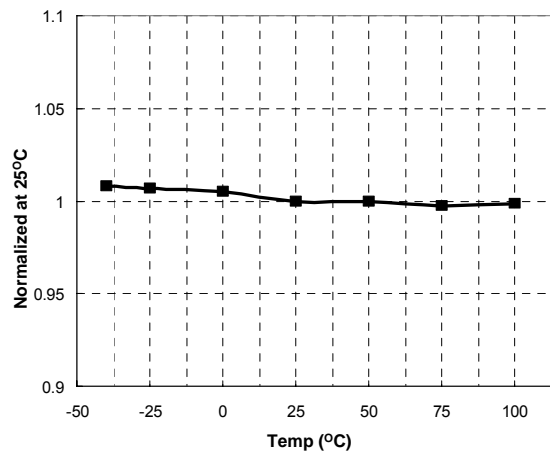

**Figure 7. High-Side  $V_{CC}$  ( $HV_{CC}$ ) Stop vs. Temperature**

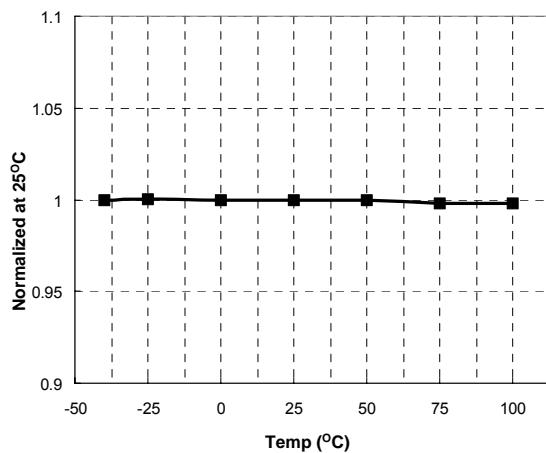

**Figure 8. Low-Side  $V_{CC}$  ( $LV_{CC}$ ) Start vs. Temperature**

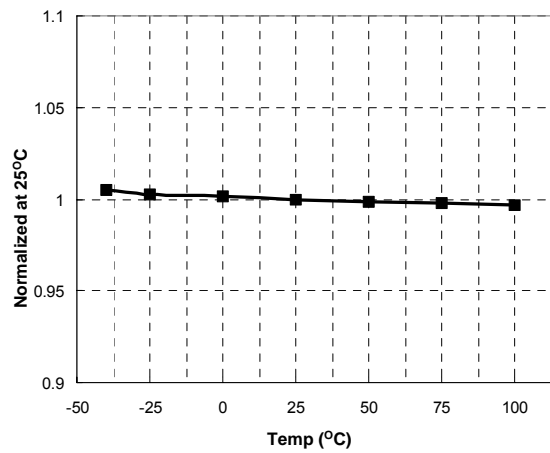

**Figure 9. Low-Side  $V_{CC}$  ( $LV_{CC}$ ) Stop vs. Temperature**



## Typical Performance Characteristics (Continued)

These characteristic graphs are normalized at  $T_A=25^\circ\text{C}$ .

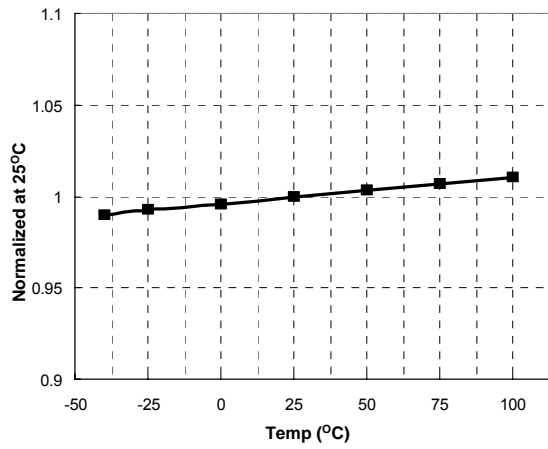

Figure 10. LV<sub>CC</sub> OVP Voltage vs. Temperature

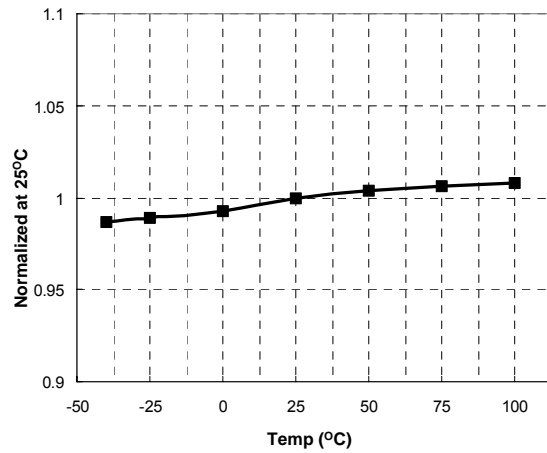

Figure 11. R<sub>T</sub> Voltage vs. Temperature

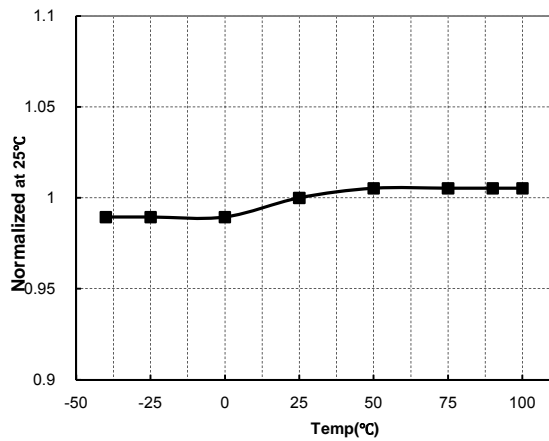

Figure 12. V<sub>CSSL</sub> vs. Temperature

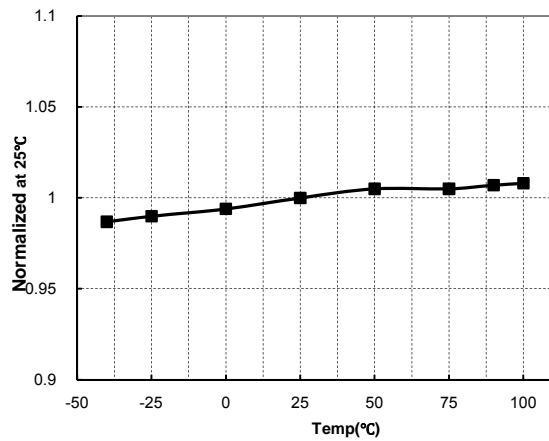

Figure 13. V<sub>CSSH</sub> vs. Temperature

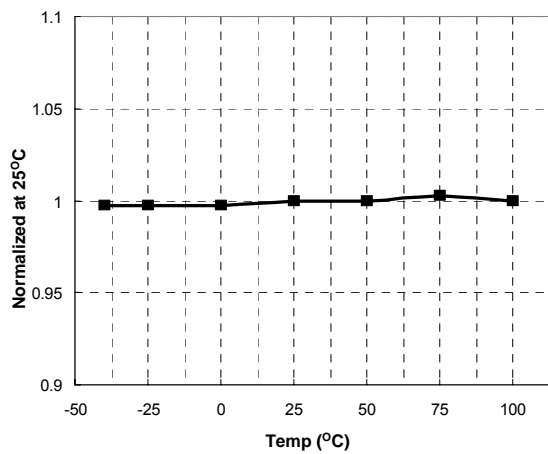

Figure 14. OCP Voltage vs. Temperature

## Functional Description

**1. Basic Operation:** FAN7621S is designed to drive high-side and low-side MOSFETs complementarily with 50% duty cycle. A fixed dead time of 350ns is introduced between consecutive transitions, as shown in Figure 15.

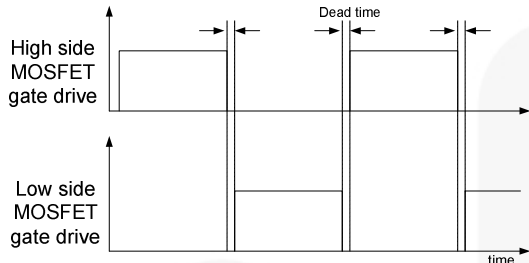

Figure 15. MOSFETs Gate Drive Signal

**2. Internal Oscillator:** FAN7621S employs a current-controlled oscillator, as shown in Figure 16. Internally, the voltage of  $R_T$  pin is regulated at 2V and the charging / discharging current for the oscillator capacitor,  $C_T$ , is obtained by copying the current flowing out of  $R_T$  pin ( $I_{CTC}$ ) using a current mirror. Therefore, the switching frequency increases as  $I_{CTC}$  increases.

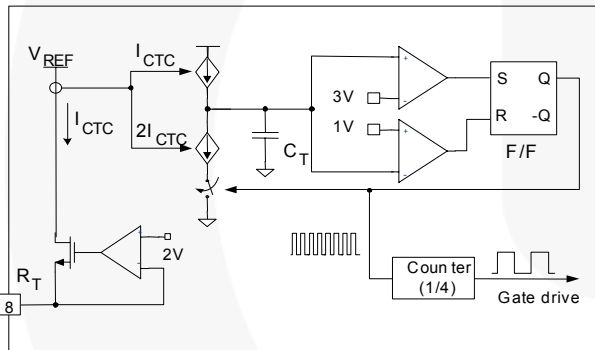

Figure 16. Current Controlled Oscillator

**3. Frequency Setting:** Figure 17 shows the typical voltage gain curve of a resonant converter, where the gain is inversely proportional to the switching frequency in the ZVS region. The output voltage can be regulated by modulating the switching frequency. Figure 18 shows the typical circuit configuration for  $R_T$  pin, where the optocoupler transistor is connected to the  $R_T$  pin to modulate the switching frequency.

The minimum switching frequency is determined as:

$$f^{\min} = \frac{5.2k\Omega}{R_{\min}} \times 100 (kHz) \quad (1)$$

Assuming the saturation voltage of the opto-coupler transistor is 0.2V, the maximum switching frequency is determined as:

$$f^{\max} = \left( \frac{5.2k\Omega}{R_{\min}} + \frac{4.68k\Omega}{R_{\max}} \right) \times 100 (kHz) \quad (2)$$

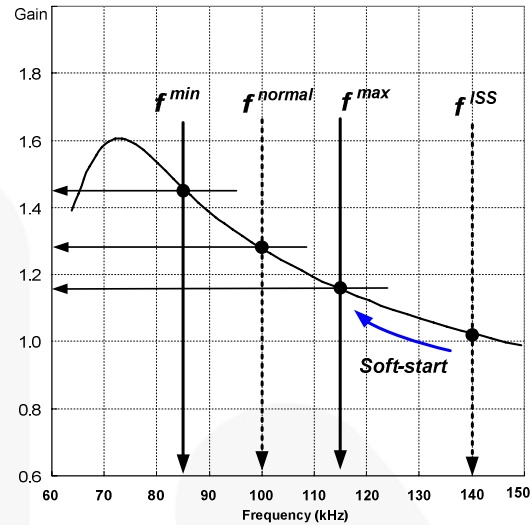

Figure 17. Resonant Converter Typical Gain Curve

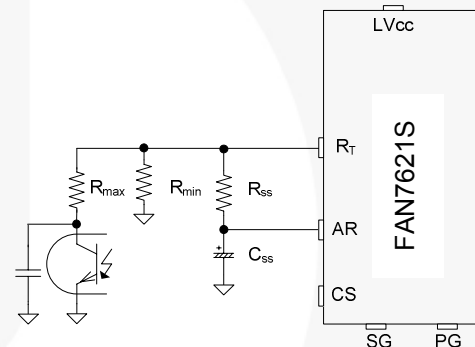

Figure 18. Frequency Control Circuit

To prevent excessive inrush current and overshoot of output voltage during startup, increase the voltage gain of the resonant converter progressively. Since the voltage gain of the resonant converter is inversely proportional to the switching frequency, the soft-start is implemented by sweeping down the switching frequency from an initial high frequency ( $f^{ISS}$ ) until the output voltage is established. The soft-start circuit is made by connecting R-C series network on the  $R_T$  pin, as shown in Figure 18. FAN7621S also has an internal soft-start of 3ms to reduce the current overshoot during the initial cycles, which adds 40kHz to the initial frequency of the external soft-start circuit, as shown in Figure 19. The initial frequency of the soft-start is given as:

$$f^{ISS} = \left( \frac{5.2k\Omega}{R_{\min}} + \frac{5.2k\Omega}{R_{SS}} \right) \times 100 + 40 (kHz) \quad (3)$$

It is typical to set the initial (soft-start) frequency two ~ three times the resonant frequency ( $f_0$ ) of the resonant network.

The soft-start time is three to four times the RC time constant. The RC time constant is as follows:

$$t_{SS} = R_{SS} \cdot C_{SS} \quad (4)$$

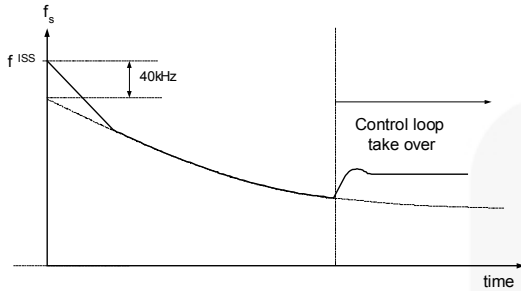

**Figure 19. Frequency Sweeping of Soft-Start**

**4. Self Auto-restart:** The FAN7621S can restart automatically even if a built-in protection is triggered with external supply voltage. As shown in Figure 20 and Figure 21; once any protections are triggered, M1 switch turns on and V-I converter is disabled.  $C_{SS}$  starts to be discharged until the  $V_{C_{SS}}$  across  $C_{SS}$  drops to  $V_{C_{SSL}}$ . Then all protections are reset, M1 turns off, and V-I converter resumes. The FAN7621S starts switching again with soft-start. If the protections occur while  $V_{C_{SS}}$  is under  $V_{C_{SSL}}$  and  $V_{C_{SSH}}$  level, the switching is terminated immediately,  $V_{C_{SS}}$  continues to increase until reaching  $V_{C_{SSH}}$ , then  $C_{SS}$  is discharged by M1.

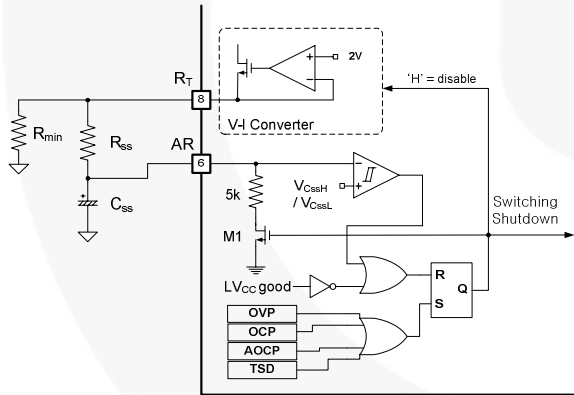
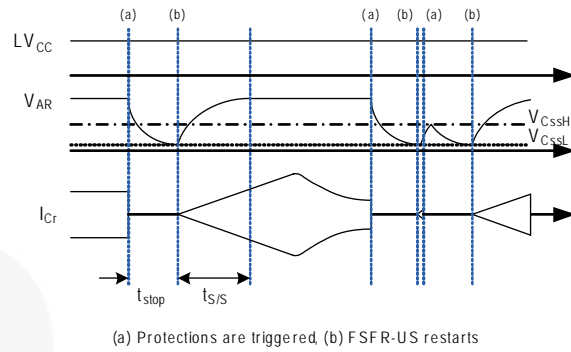

**Figure 20. Internal Block of AR Pin**

After protections trigger, FAN7621S is disabled during the stop-time,  $t_{stop}$ , where  $V_{C_{SS}}$  decreases and reaches to  $V_{C_{SSL}}$ . The stop-time of FAN7621S can be estimated as:

$$t_{stop} = C_{ss} \cdot \{(R_{ss} + R_{min}) \parallel 5k\Omega\} \quad (5)$$

For the soft-start time,  $t_{s/s}$  it can be set as Equation (4).



**Figure 21. Self Auto-Restart Operation**

**5. Protection Circuits:** The FAN7621S has several self-protective functions, such as Over-Current Protection (OCP), Abnormal Over-Current Protection (AOCP), Over-Voltage Protection (OVP), and Thermal Shutdown (TSD). These protections are auto-restart mode protections, as shown in Figure 21.

Once a fault condition is detected, switching is terminated and the MOSFETs remain off. When  $LV_{CC}$  falls to the  $LV_{CC}$  stop voltage of 10V or the AR signal is HIGH, the protection is reset. FAN7621S resumes normal operation when  $LV_{CC}$  reaches the start voltage of 12.5V.

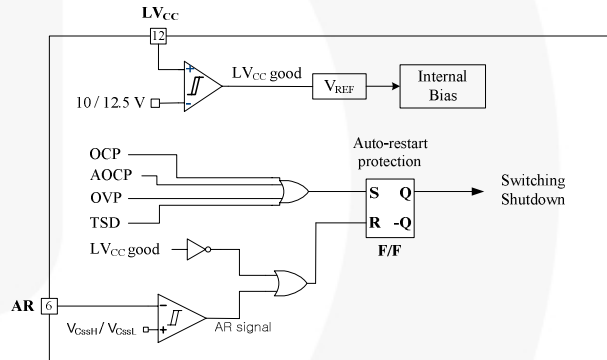

**Figure 22. Protection Blocks**

**5.1 Over-Current Protection (OCP):** When the sensing pin voltage drops below -0.58V, OCP is triggered and the MOSFETs remain off. This protection has a shutdown time delay of 1.5 $\mu$ s to prevent premature shutdown during startup.

**5.2 Abnormal Over-Current Protection (AOCP):** If the secondary rectifier diodes are shorted, large current with extremely high di/dt can flow through the MOSFET before OCP is triggered. AOCP is triggered without shutdown delay when the sensing pin voltage drops below -0.9V.

**5.3 Over-Voltage Protection (OVP):** When the  $LV_{CC}$  reaches 23V, OVP is triggered. This protection is used when auxiliary winding of the transformer to supply  $V_{CC}$  to the controller is utilized.

**5.4 Thermal Shutdown (TSD):** If the temperature of the junction exceeds approximately 130°C, the thermal shutdown triggers.

**6. Current Sensing Using Resistor:** FAN7621S senses drain current as a negative voltage, as shown in Figure 23 and Figure 24. Half-wave sensing allows low power dissipation in the sensing resistor, while full-wave sensing has less switching noise in the sensing signal.

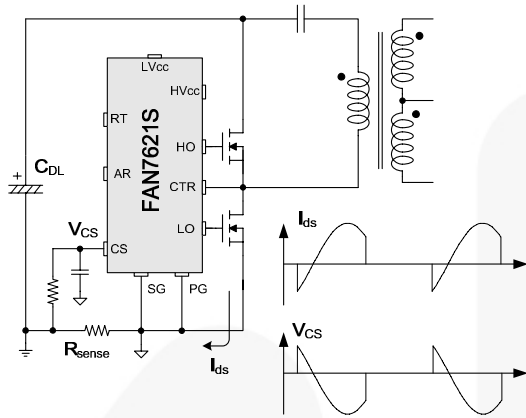

Figure 23. Half-Wave Sensing

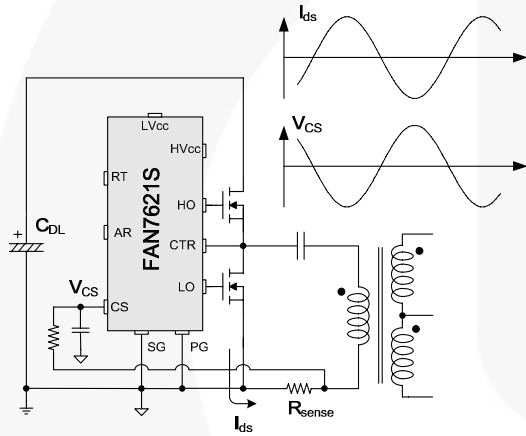

Figure 24. Full-Wave Sensing

**7. PCB Layout Guidelines:** Duty imbalance problems may occur due to the radiated noise from the main transformer, the inequality of the secondary-side leakage inductances of main transformer, and so on. It is one of the dominant reasons that the control components in the vicinity of  $R_T$  pin are enclosed by the primary current flow pattern on PCB layout. The direction of the magnetic field on the components caused by the primary current flow is changed when the high- and low-side MOSFET turns on by turns. The magnetic fields with opposite direction from each other induce a current through, into, or out of the  $R_T$  pin, which makes the turn-on duration of each MOSFET different. It is strongly recommended to separate the control components in the vicinity of  $R_T$  pin from the primary current flow pattern on PCB layout. **Error! Reference source not found.** shows an example for the duty-balanced case. The yellow and blue lines show the primary current flows when the lower-side and higher-side MOSFETs turn on, respectively. The primary current does not enclose any component of controller.

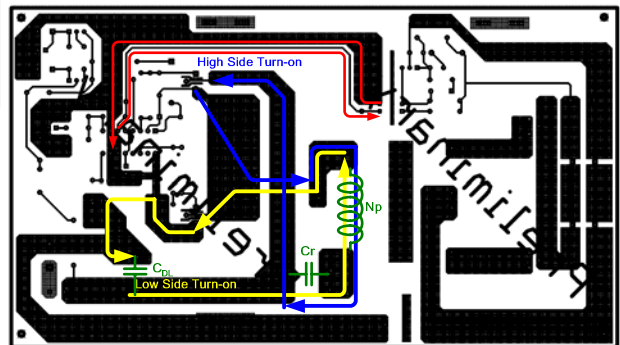
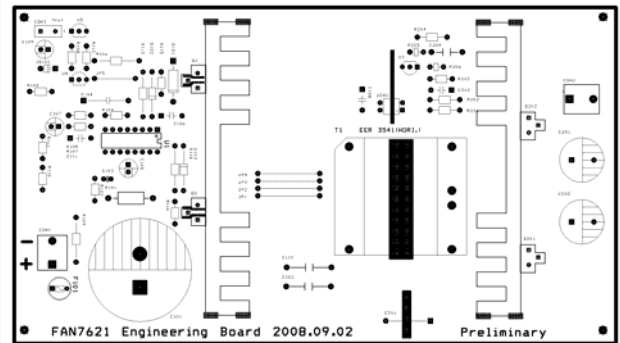
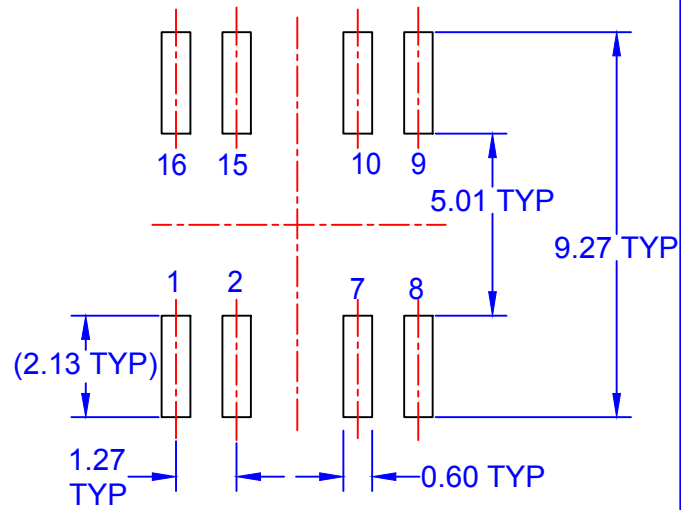
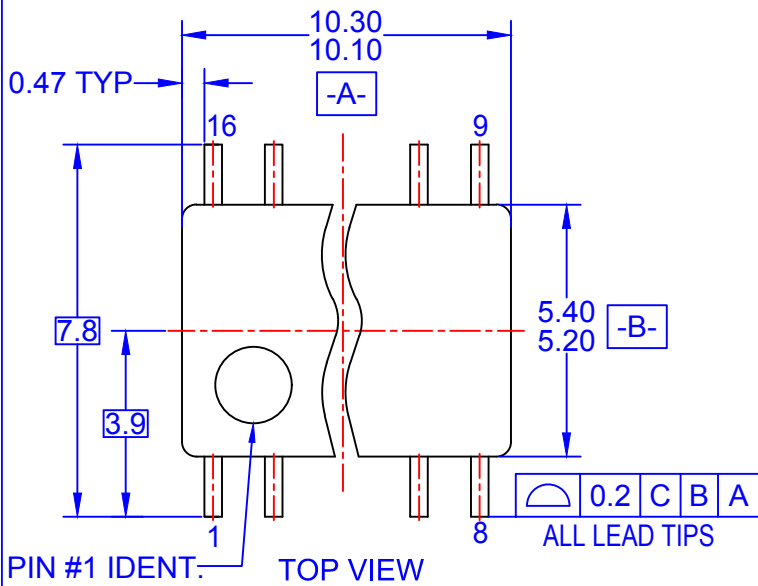
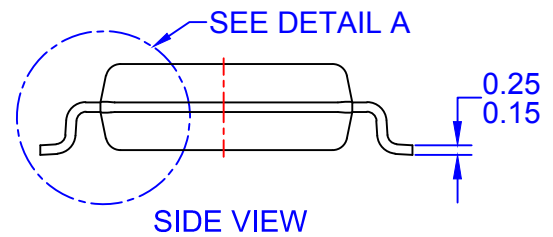
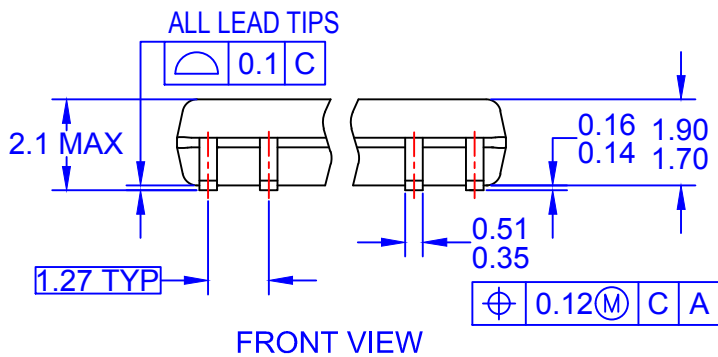

Figure 25. Example for Duty Balancing



LAND PATTERN RECOMMENDATION



NOTES:

- A. CONFORMS TO EIAJ EDR-7320 REGISTRATION, ESTABLISHED IN DECEMBER, 1998.
- B. DIMENSIONS ARE IN MILLIMETERS.
- C. DIMENSIONS ARE EXCLUSIVE OF BURRS, MOLD FLASH, AND TIE BAR EXTRUSIONS.
- D. DRAWING FILENAME: MKT-M16Drev5

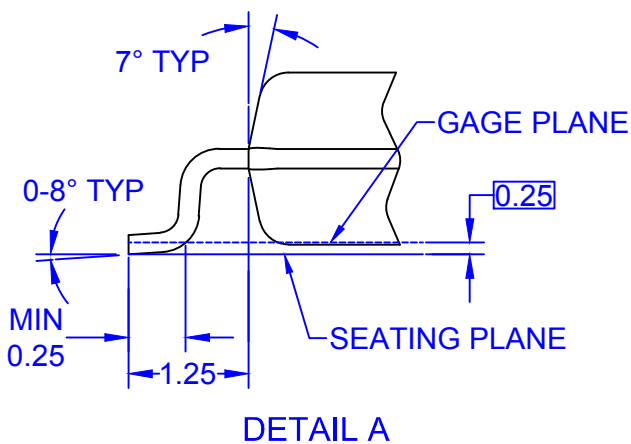

ON Semiconductor and  are trademarks of Semiconductor Components Industries, LLC dba ON Semiconductor or its subsidiaries in the United States and/or other countries. ON Semiconductor owns the rights to a number of patents, trademarks, copyrights, trade secrets, and other intellectual property. A listing of ON Semiconductor's product/patent coverage may be accessed at [www.onsemi.com/site/pdf/Patent-Marking.pdf](http://www.onsemi.com/site/pdf/Patent-Marking.pdf). ON Semiconductor reserves the right to make changes without further notice to any products herein. ON Semiconductor makes no warranty, representation or guarantee regarding the suitability of its products for any particular purpose, nor does ON Semiconductor assume any liability arising out of the application or use of any product or circuit, and specifically disclaims any and all liability, including without limitation special, consequential or incidental damages. Buyer is responsible for its products and applications using ON Semiconductor products, including compliance with all laws, regulations and safety requirements or standards, regardless of any support or applications information provided by ON Semiconductor. "Typical" parameters which may be provided in ON Semiconductor data sheets and/or specifications can and do vary in different applications and actual performance may vary over time. All operating parameters, including "Typicals" must be validated for each customer application by customer's technical experts. ON Semiconductor does not convey any license under its patent rights nor the rights of others. ON Semiconductor products are not designed, intended, or authorized for use as a critical component in life support systems or any FDA Class 3 medical devices or medical devices with a same or similar classification in a foreign jurisdiction or any devices intended for implantation in the human body. Should Buyer purchase or use ON Semiconductor products for any such unintended or unauthorized application, Buyer shall indemnify and hold ON Semiconductor and its officers, employees, subsidiaries, affiliates, and distributors harmless against all claims, costs, damages, and expenses, and reasonable attorney fees arising out of, directly or indirectly, any claim of personal injury or death associated with such unintended or unauthorized use, even if such claim alleges that ON Semiconductor was negligent regarding the design or manufacture of the part. ON Semiconductor is an Equal Opportunity/Affirmative Action Employer. This literature is subject to all applicable copyright laws and is not for resale in any manner.

## PUBLICATION ORDERING INFORMATION

### LITERATURE FULFILLMENT:

Literature Distribution Center for ON Semiconductor  
19521 E. 32nd Pkwy, Aurora, Colorado 80011 USA  
**Phone:** 303-675-2175 or 800-344-3860 Toll Free USA/Canada  
**Fax:** 303-675-2176 or 800-344-3867 Toll Free USA/Canada  
**Email:** [orderlit@onsemi.com](mailto:orderlit@onsemi.com)

**N. American Technical Support:** 800-282-9855 Toll Free  
USA/Canada  
**Europe, Middle East and Africa Technical Support:**  
Phone: 421 33 790 2910  
**Japan Customer Focus Center**  
Phone: 81-3-5817-1050

**ON Semiconductor Website:** [www.onsemi.com](http://www.onsemi.com)  
**Order Literature:** <http://www.onsemi.com/orderlit>  
For additional information, please contact your local  
Sales Representative

# Mouser Electronics

Authorized Distributor

Click to View Pricing, Inventory, Delivery & Lifecycle Information:

[ON Semiconductor:](#)

[FAN7621SSJ](#) [FAN7621SSJX](#)